

Система обозначения оправки и удлинителей для фрез

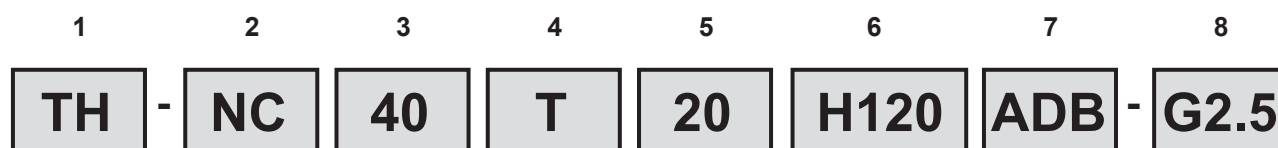

1 Наименование инструмента:

ТН - Вспомогательный инструмент;
V - Твердосплавное исполнение;

2 Тип хвостовика вспомогательного инструмента оправки:

SK - Метрический конус 7/24 (DIN 2080);
NC - Метрический конус 7/24 для станков с ЧПУ (DIN69871 A);
BT - Метрический конус 7/24 для станков с ЧПУ по стандарту Японии (MAS BT 403);
CV - Метрический конус 7/24 для станков с ЧПУ по стандарту США (CAT-V flange);
HA - Хвостовик полый конический типа HSK DIN 69893, форма A;
COx - Хвостовик полигональный конический типа DIN 26623-1;
W - Цилиндрический хвостовик с лысками типа «Weldon» (DIN 1835 B);
Z - Цилиндрический хвостовик (DIN 1835 A);
MK - Конус Морзе DIN 228 A;
N - Цилиндрический хвостовик с наклонной лыской типа Whistle Notch DIN 1835E;
WN - Цилиндрический комбинированный хвостовик с лысками типа «Weldon» (DIN 1835 B) и Whistle Notch DIN 1835E;

3 Размер хвостовика вспомогательного инструмента.

4 Механизм зажима режущего инструмента:

W - Патрон системы «Weldon» для цилиндрических хвостовиков с лыской (DIN 1835 B);
Z - Цанговый патрон системы «OZ»;
ML - Втулка переходная для сверл с конусом Морзе с лапкой;
MG - Втулка переходная для фрез с конусом Морзе с резьбовым отверстием;
N - Патрон системы Whistle Notch для фрез и сверл с цилиндрическим хвостовиком с наклонной лыской по DIN 1835E;
WN - Патрон системы Weldon-Whistle Notch для фрез и сверл с комбинированным цилиндрическим хвостовиком по DIN 1835E и DIN 1835B;
G - Патрон для концевых фрез с коротким резьбовым хвостовиком;
T - Термопатрон;
D - Патрон сверлильный высокоточный;
A - Оправки для торцовых и насадных фрез с посадкой форм A;
B - Оправки для торцовых и насадных фрез с посадкой форм B;
C - Оправки для торцовых и насадных фрез с посадкой форм C;
S - Оправка комбинированная для насадных фрез;
SK - Втулка переходная для инструмента с хвостовиком 7/24 DIN 2080;
NC - Втулка переходная для инструмента с хвостовиком 7/24 DIN 69871;
BT - Втулка переходная для инструмента с хвостовиком 7/24 MAS BT 403;
COx - Втулка переходная для инструмента с хвостовиком DIN 26623-1;

5 Диаметр посадочной части в мм или размер посадочного конуса режущего инструмента, диапазон резьб, нарезаемых метчиком (для резьбовых патронов).

6 Вылет от торца шпинделя для оправок и патронов и от базового размера для удлинителей в мм.

7 Исполнение хвостовика оправки 7/24 с отверстием для подачи охлаждающей жидкости через тело инструмента.

AD - центральная подача СОЖ через сквозное отверстие в хвостовике;
ADB - центральная подача СОЖ через фланец и сквозное отверстие в хвостовике;

8 Обозначение класса дисбаланса оправки с механизмом балансировки.

Удлинитель и оправки для концевых фрез с резьбовым хвостовиком



		Стр.
ТН-W...G...H	Удлинители с цилиндрическим хвостовиком «Weldon» (DIN1835 B)	446
ТН-Z...G...H	Удлинители с цилиндрическим хвостовиком DIN1835A	446
ТН-МК...G...H	Удлинители с коническим хвостовиком Морзе DIN228A	446
ТНV-Z...G...H	Удлинители с твердосплавным цилиндрическим хвостовиком DIN1835A	447
ТН-НС...G...H	Оправки с конусом 7/24 для станков с ЧПУ (DIN69871 A)	448
ТН-ВТ...G...H	Оправки с конусом 7/24 MAS BT 403	449
ТН-НА...G...H	Оправки с конусом HSK DIN 69893 Form A	450
ТН-НА...G...H...G2.5	Оправки балансируемые с конусом HSK DIN 69893 Form A	451

Удлинитель с цилиндрическим хвостовиком «Weldon» (DIN1835 B)

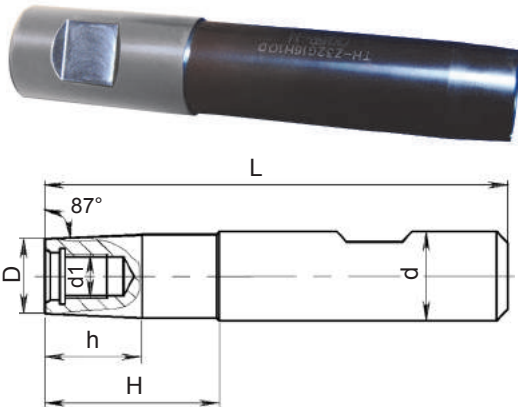

Обозначение	Размеры, мм					
	d	d1	D	h	H	L

TH-W...G...H

TH-W16G08H032	16	M08	14,5	14,31	32	80
TH-W16G08H052	16	M08	14,5	14,31	52	100
TH-W16G08H102	16	M08	14,5	14,31	102	150
TH-W16G08H112	16	M08	14,5	14,31	112	160
TH-W20G10H030	20	M10	18,5	14,31	30	80
TH-W20G10H050	20	M10	18,5	14,31	50	100
TH-W20G10H102	20	M10	18,5	14,31	102	152
TH-W20G10H110	20	M10	18,5	14,31	110	160
TH-W25G12H034	25	M12	22	17	34	90
TH-W25G12H044	25	M12	22	17	44	100
TH-W25G12H104	25	M12	22	17	104	160
TH-W25G12H144	25	M12	22	17	144	200
TH-W32G16H040	32	M16	28	22	40	100
TH-W32G16H045	32	M16	28	22	45	105
TH-W32G16H072	32	M16	28	22	72	132
TH-W32G16H100	32	M16	28	22	100	160
TH-W32G16H132	32	M16	28	22	132	192
TH-W32G16H140	32	M16	28	22	140	200
TH-W32G16H180	32	M16	28	22	180	240

Удлинитель с цилиндрическим хвостовиком DIN1835A

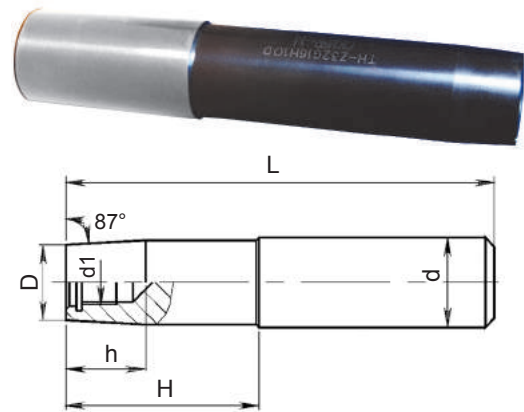

Обозначение	Размеры, мм					
	d	d1	D	h	H	L

TH-Z...G...H

TH-Z16G08H032	16	M08	14,5	14,31	32	80
TH-Z16G08H052	16	M08	14,5	14,31	52	100
TH-Z16G08H102	16	M08	14,5	14,31	102	150
TH-Z16G08H112	16	M08	14,5	14,31	112	160
TH-Z20G10H030	20	M10	18,5	14,31	30	80
TH-Z20G10H050	20	M10	18,5	14,31	50	100
TH-Z20G10H102	20	M10	18,5	14,31	102	152
TH-Z20G10H110	20	M10	18,5	14,31	110	160
TH-Z25G12H034	25	M12	22	17	34	90
TH-Z25G12H044	25	M12	22	17	44	100
TH-Z25G12H104	25	M12	22	17	104	160
TH-Z25G12H144	25	M12	22	17	144	200
TH-Z32G16H040	32	M16	28	22	40	100
TH-Z32G16H045	32	M16	28	22	45	105
TH-Z32G16H072	32	M16	28	22	72	132
TH-Z32G16H100	32	M16	28	22	100	160
TH-Z32G16H132	32	M16	28	22	132	192
TH-Z32G16H140	32	M16	28	22	140	200
TH-Z32G16H180	32	M16	28	22	180	240

Удлинитель с коническим хвостовиком Морзе DIN228A

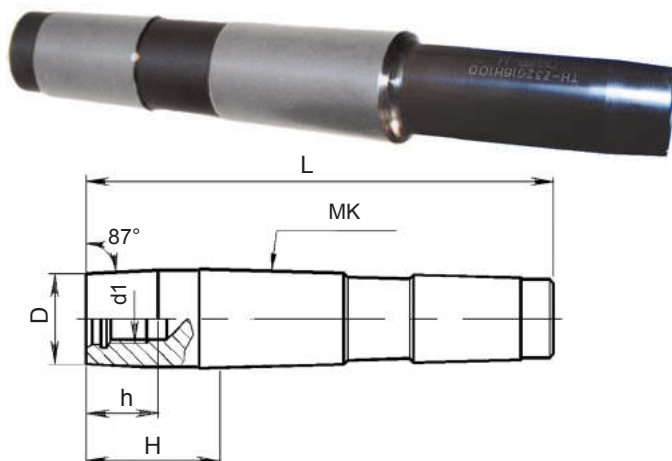

Обозначение	МК	Размеры, мм				
		d1	D	h	H	L

TH-MK...G...H

TH-MK2G08H029	МК2	M08	14,5	-	29,5	93,5
TH-MK2G08H059	МК2	M08	14,5	24,5	59,5	123,5
TH-MK2G10H029	МК2	M10	18,5	-	29,5	93,5
TH-MK2G10H059	МК2	M10	18,5	24,5	59,5	123,5
TH-MK3G12H020	МК3	M12	22	22	20	101
TH-MK3G12H069	МК3	M12	22	22	69	150
TH-MK4G16H059	МК4	M16	28	34,73	59,5	162
TH-MK4G16H099	МК4	M16	28	34,73	99,5	202
TH-MK5G16H128	МК5	M16	28	122	128,5	258

Удлинители с твердосплавным цилиндрическим хвостовиком DIN1835A

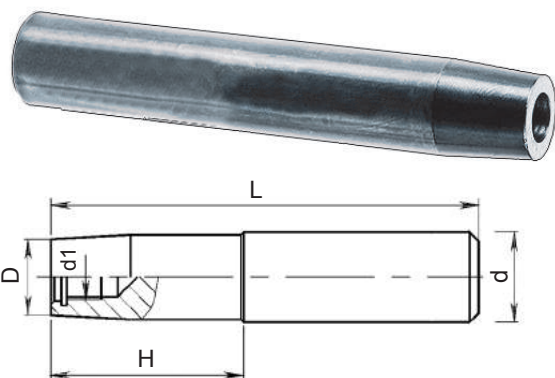

Обозначение	Размеры, мм				
	d	d1	D	H	L
THV-Z...G...H					
THV-Z16G08H040	16	M08	12,8	40	95
THV-Z16G08H060	16	M08	12,8	60	115
THV-Z16G08H080	16	M08	12,8	80	135
THV-Z16G08H100	16	M08	12,8	100	155
THV-Z16G08H120	16	M08	12,8	120	175
THV-Z20G10H040	20	M10	17,8	40	100
THV-Z20G10H060	20	M10	17,8	60	120
THV-Z20G10H080	20	M10	17,8	80	140
THV-Z20G10H100	20	M10	17,8	100	160
THV-Z20G10H120	20	M10	17,8	120	180
THV-Z25G12H080	25	M12	23	80	136
THV-Z25G12H100	25	M12	23	100	156
THV-Z25G12H120	25	M12	23	120	176
THV-Z25G12H140	25	M12	23	140	196
THV-Z25G12H160	25	M12	23	160	216
THV-Z32G16H100	32	M16	29	100	160
THV-Z32G16H150	32	M16	29	150	210
THV-Z32G16H200	32	M16	29	200	260
THV-Z32G16H250	32	M16	29	250	310
THV-Z32G16H300	32	M16	29	300	360

Оправки с конусом 7/24 для станков с ЧПУ (DIN69871 A)

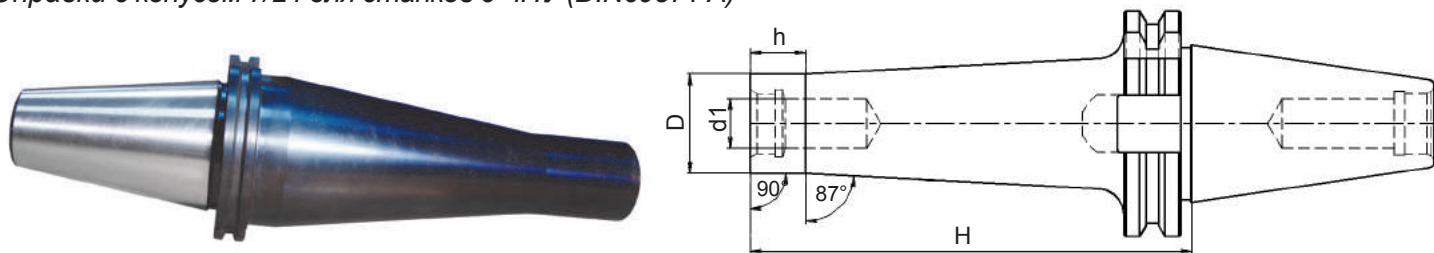

Обозначение	Размеры, мм				
	NC	d1	D	h	H
TH-NC40...G...H					
TH-NC40G08H044	40	M08	13	10	44
TH-NC40G08H069	40	M08	13	10	69
TH-NC40G08H094	40	M08	13	10	94
TH-NC40G08H119	40	M08	13	10	119
TH-NC40G10H044	40	M10	18	10	44
TH-NC40G10H069	40	M10	18	10	69
TH-NC40G10H094	40	M10	18	10	94
TH-NC40G10H119	40	M10	18	10	119
TH-NC40G10H150	40	M10	18	10	150
TH-NC40G12H044	40	M12	21	10	44
TH-NC40G12H069	40	M12	21	10	69
TH-NC40G12H094	40	M12	21	10	94
TH-NC40G12H119	40	M12	21	10	119
TH-NC40G12H144	40	M12	21	10	144
TH-NC40G12H169	40	M12	21	10	169
TH-NC40G16H044	40	M16	29	10	44
TH-NC40G16H069	40	M16	29	10	69
TH-NC40G16H094	40	M16	29	10	96
TH-NC40G16H119	40	M16	29	10	119
TH-NC40G16H144	40	M16	29	10	144
TH-NC40G16H169	40	M16	29	10	169
TH-NC50...G...H					
TH-NC50G08H069	50	M08	13	10	69
TH-NC50G08H119	50	M08	13	10	119
TH-NC50G08H169	50	M08	13	10	169
TH-NC50G10H069	50	M10	18	10	69
TH-NC50G10H119	50	M10	18	10	119
TH-NC50G10H169	50	M10	18	10	169
TH-NC50G12H069	50	M12	21	10	69
TH-NC50G12H119	50	M12	21	10	119
TH-NC50G12H169	50	M12	21	10	169
TH-NC50G12H200	50	M12	21	10	200
TH-NC50G16H069	50	M16	29	10	69
TH-NC50G16H119	50	M16	29	10	119
TH-NC50G16H169	50	M16	29	10	169
TH-NC50G16H200	50	M16	29	10	200
TH-NC50G16H250	50	M16	29	10	250
TH-NC50G20H075	50	M20	36,2	10	75
TH-NC50G20H100	50	M20	36,2	10	100
TH-NC50G20H150	50	M20	36,2	10	150
TH-NC50G20H200	50	M20	36,2	10	200
TH-NC50G24H095ADB	50	M24	45	20	95
TH-NC50G24H228ADB	50	M24	45	54	228,75

Оправки с конусом 7/24 MAS BT 403

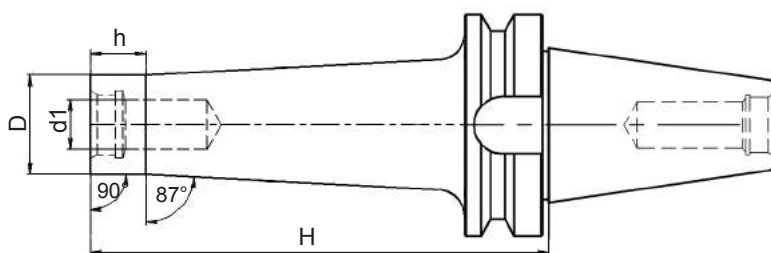

Обозначение	Размеры, мм				
	BT	d1	D	h	H
TH-BT40...G...H					
TH-BT40G08H052	40	M08	13	10	52
TH-BT40G08H077	40	M08	13	10	77
TH-BT40G08H102	40	M08	13	10	102
TH-BT40G08H127	40	M08	13	10	127
TH-BT40G10H052	40	M10	18	10	52
TH-BT40G10H077	40	M10	18	10	77
TH-BT40G10H102	40	M10	18	10	102
TH-BT40G10H127	40	M10	18	10	127
TH-BT40G10H150	40	M10	18	10	150
TH-BT40G12H052	40	M12	21	10	52
TH-BT40G12H102	40	M12	21	10	102
TH-BT40G12H152	40	M12	21	10	152
TH-BT40G16H052	40	M16	29	10	52
TH-BT40G16H102	40	M16	29	10	102
TH-BT40G16H152	40	M16	29	10	152
TH-BT40G16H170	40	M16	29	10	170
TH-BT50...G...H					
TH-BT50G08H088	50	M08	13	10	88
TH-BT50G08H138	50	M08	13	10	138
TH-BT50G08H188	50	M08	13	10	188
TH-BT50G10H088	50	M10	18	10	88
TH-BT50G10H138	50	M10	18	10	138
TH-BT50G10H188	50	M10	18	10	188
TH-BT50G12H088	50	M12	21	10	88
TH-BT50G12H138	50	M12	21	10	138
TH-BT50G12H188	50	M12	21	10	188
TH-BT50G12H220	50	M12	21	10	220
TH-BT50G16H088	50	M16	21	10	88
TH-BT50G16H138	50	M16	29	10	138
TH-BT50G16H188	50	M16	29	10	188
TH-BT50G16H220	50	M16	29	10	220
TH-BT50G16H270	50	M16	29	10	270
TH-BT50G20H070	50	M20	29	10	70
TH-BT50G20H120	50	M20	36,2	10	120
TH-BT50G20H170	50	M20	36,2	10	170
TH-BT50G20H220	50	M20	36,2	10	220

Оправки с конусом HSK DIN 69893 Form A

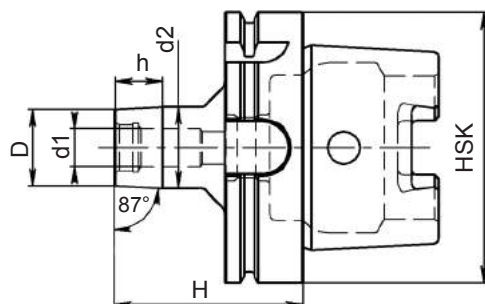

Обозначение	Размеры, мм					
	HSK	d1	d2	D	h	H
TH-HA063...G...H $n_{max} = 8\ 000$ об/мин						
TH-HA063G08H051	63	M 8	15,5	14,5	10	51
TH-HA063G08H076	63	M 8	15,5	14,5	10	76
TH-HA063G08H101	63	M 8	15,5	14,5	10	101
TH-HA063G08H120	63	M 8	15,5	14,5	10	120
TH-HA063G10H051	63	M 10	19,5	18,5	10	51
TH-HA063G10H076	63	M 10	19,5	18,5	10	76
TH-HA063G10H100	63	M 10	19,5	18,5	10	100
TH-HA063G10H126	63	M 10	19,5	18,5	10	126
TH-HA063G10H176	63	M 10	19,5	18,5	10	176
TH-HA063G12H051	63	M 12	23	22	10	51
TH-HA063G12H076	63	M 12	23	22	10	76
TH-HA063G12H101	63	M 12	23	22	10	101
TH-HA063G12H126	63	M 12	23	22	10	126
TH-HA063G12H176	63	M 12	23	22	10	176
TH-HA063G16H076	63	M 16	30	28	19	76
TH-HA063G16H101	63	M 16	30	28	19	101
TH-HA063G16H126	63	M 16	30	28	19	126
TH-HA063G16H140	63	M 16	30	28	19	140
TH-HA063G16H176	63	M 16	30	28	19	176
TH-HA100...G...H $n_{max} = 8\ 000$ об/мин						
TH-HA100G12H079	100	M 12	23	22	10	79
TH-HA100G12H129	100	M 12	23	22	10	129
TH-HA100G12H179	100	M 12	23	22	10	179
TH-HA100G12H200	100	M 12	23	22	10	200
TH-HA100G16H079	100	M 16	30	28	19	79
TH-HA100G16H129	100	M 16	30	28	19	129
TH-HA100G16H179	100	M 16	30	28	19	179
TH-HA100G16H200	100	M 16	30	28	19	200
TH-HA100G16H250	100	M 16	30	28	19	250

Оправки балансируемые с конусом HSK DIN 69893 Form A

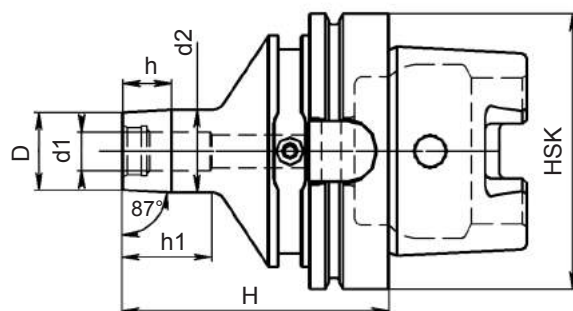

Обозначение	Размеры, мм						
	HSK	d1	d2	D	h	H	h1
TH-HA63...G...H...G2.5		<i>n_{max} = 25 000 об/мин</i>					
TH-HA063G08H060G2.5	63	M 8	15,5	14,5	10	60	14
TH-HA063G08H085G2.5	63	M 8	15,5	14,5	10	85	39
TH-HA063G08H110G2.5	63	M 8	15,5	14,5	10	110	64
TH-HA063G08H135G2.5	63	M 8	15,5	14,5	10	135	85
TH-HA063G10H065G2.5	63	M 10	19,5	18,5	10	65	16
TH-HA063G10H090G2.5	63	M 10	19,5	18,5	10	90	41
TH-HA063G10H115G2.5	63	M 10	19,5	18,5	10	115	66
TH-HA063G10H140G2.5	63	M 10	19,5	18,5	10	140	91
TH-HA063G10H165G2.5	63	M 10	19,5	18,5	10	165	116
TH-HA063G12H075G2.5	63	M 12	23	22	10	75	26
TH-HA063G12H100G2.5	63	M 12	23	22	10	100	51
TH-HA063G12H125G2.5	63	M 12	23	22	10	125	76
TH-HA063G12H150G2.5	63	M 12	23	22	10	150	101
TH-HA063G12H175G2.5	63	M 12	23	22	10	175	126
TH-HA063G16H080G2.5	63	M 16	30	28	19	80	31
TH-HA063G16H105G2.5	63	M 16	30	28	19	105	59
TH-HA063G16H130G2.5	63	M 16	30	28	19	130	81
TH-HA063G16H155G2.5	63	M 16	30	28	19	155	109
TH-HA063G16H180G2.5	63	M 16	30	28	19	180	134
TH-HA100...G...H...G2.5		<i>n_{max} = 16 000 об/мин</i>					
TH-HA100G12H070G2.5	100	M 12	23	22	10	70	21
TH-HA100G12H115G2.5	100	M 12	23	22	10	115	60
TH-HA100G12H165G2.5	100	M 12	23	22	10	165	110
TH-HA100G16H075G2.5	100	M 16	30	28	19	75	21
TH-HA100G16H115G2.5	100	M 16	30	28	19	115	60
TH-HA100G16H165G2.5	100	M 16	30	28	19	165	110
TH-HA100G16H215G2.5	100	M 16	30	28	19	215	156

Балансировочный элемент



HSK63 B510805
HSK100 B840805

Винт балансировки



H600500-30

Ключ балансировки



7003H

Вспомогательный инструмент СКИФ-М с хвостовиком 7/24 (DIN 2080) для станков с ручной сменой инструмента



		Стр.
TH-SK...W...H	Оправки 7/24 DIN 2080 для концевых фрез с хвостовиком типа Weldon	453
TH-SK...S...H	Оправки комбинированные 7/24 DIN 2080 для насадных фрез	454
TH-SK...A,B,C...H	Оправки 7/24 DIN 2080 для торцовых фрез с посадкой форм А, В и С	454
TH-SK...MG...H	Втулки переходные 7/24 DIN 2080 для фрез с конусом Морзе с резьбовым отверстием	455
TH-SK...ML...H	Втулки переходные 7/24 DIN 2080 для сверл с конусом Морзе с лапкой	455
TH-SK...SK,NC,BT...H	Втулки переходные с 7/24 DIN 2080 на 7/24 DIN 2080, DIN 69871, MAS BT 403	455
TH-SK...D...H	Патроны сверлильные высокоточные 7/24 DIN 2080	456
TH-SK...Z...H	Патроны цанговые 7/24 DIN 2080 системы OZ	456
TH-SK...M-M	Патроны резьбонарезные 7/24 DIN 2080	456

Оправки 7/24 DIN 2080 для концевых фрез с хвостовиком типа Weldon

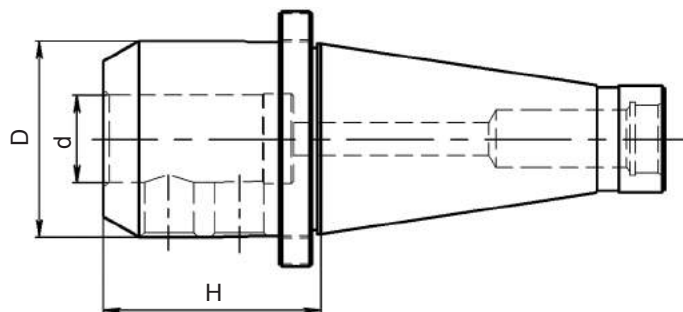

Обозначение	Размеры, мм			
	SK	d	D	H
TH-SK40...W...H				
TH-SK40W06H050	40	6	25	50
TH-SK40W08H050	40	8	28	50
TH-SK40W10H050	40	10	35	50
TH-SK40W12H050	40	12	42	50
TH-SK40W14H050	40	14	42	50
TH-SK40W16H063	40	16	48	63
TH-SK40W18H063	40	18	48	63
TH-SK40W20H063	40	20	52	63
TH-SK40W22H063	40	22	54	63
TH-SK40W25H080	40	25	73	80
TH-SK40W32H080	40	32	70	80

TH-SK50...W...H				
TH-SK50W06H063	50	6	25	63
TH-SK50W08H063	50	8	28	63
TH-SK50W10H063	50	10	35	63
TH-SK50W12H063	50	12	42	63
TH-SK50W14H063	50	14	44	63
TH-SK50W16H063	50	16	48	63
TH-SK50W18H063	50	18	48	63
TH-SK50W20H063	50	20	52	63
TH-SK50W22H063	50	22	52	63
TH-SK50W25H080	50	25	65	80
TH-SK50W32H080	50	32	72	80
TH-SK50W40H090	50	40	90	90
TH-SK50W40H120	50	40	90	120
TH-SK50W50H100	50	50	100	100
TH-SK50W50H130	50	50	100	130

Винт крепления "Weldon"

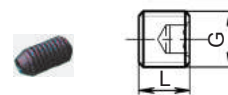

d, мм	G, мм	L, мм
6	M 6	10
8	M 8	10
10	M 10	12
12	M 12	16
14	M 12	16
16	M 14	16
18	M 14	16
20	M 16	16
22	M 16	16
25	M 18x2	20
32	M 20x2	20
40	M 20x2	25
50	M 24x2	25

Оправки комбинированные 7/24 DIN 2080 для насадных фрез

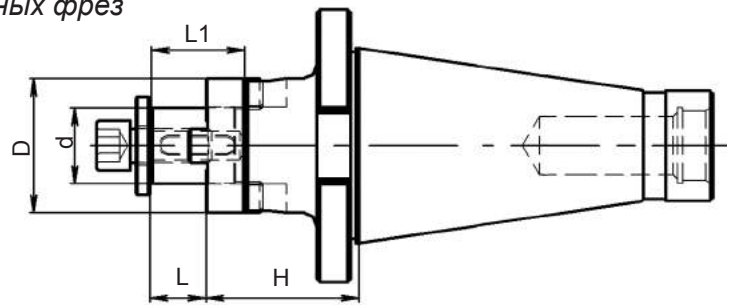

Обозначение	Размеры, мм					
	SK	d	D	H	L	L1
TH-SK40...S...H						
TH-SK40S16H052	40	16	32	52	17	27
TH-SK40S22H052	40	22	40	52	19	31
TH-SK40S27H052	40	27	48	52	21	33
TH-SK40S32H052	40	32	58	52	24	38
TH-SK40S32H075	40	32	58	75	24	38
TH-SK40S40H052	40	40	70	52	27	41
TH-SK40S40H075	40	40	70	75	27	41
TH-SK40S50H052	40	50	90	52	30	46

TH-SK50...S...H						
TH-SK50S16H055	50	16	32	55	17	27
TH-SK50S22H055	50	22	40	55	19	31
TH-SK50S27H055	50	27	48	55	21	33
TH-SK50S32H055	50	32	58	55	24	38
TH-SK50S40H055	50	40	70	55	27	41
TH-SK50S50H055	50	50	90	55	30	46
TH-SK50S60H080	50	60	110	80	36	52

Оправки 7/24 DIN 2080 для торцовых фрез с посадкой форм А, В и С

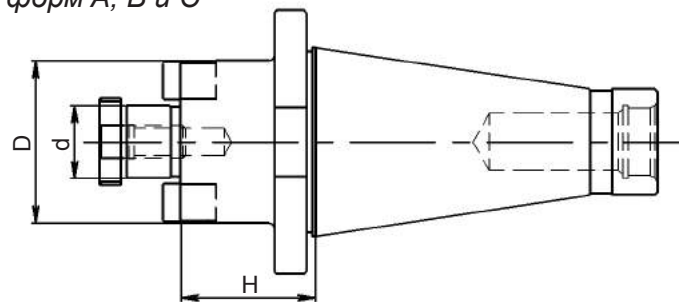

Обозначение	Размеры, мм			
	SK	d	D	H
TH-SK40...A,B,C...H				
TH-SK40A22H030	40	22	48	30
TH-SK40B27H030	40	27	60	30
TH-SK40B32H030	40	32	78	30
TH-SK40C40H030	40	40	89	30

TH-SK50...A,B,C...H				
TH-SK50A22H035	50	22	48	35
TH-SK50B27H035	50	27	60	35
TH-SK50B32H040	50	32	78	40
TH-SK50B40H033	50	40	72	33
TH-SK50C40H050	50	40	89	50
TH-SK50C60H055	50	60	129	55

Втулки переходные 7/24 DIN 2080 для фрез с конусом Морзе с резьбовым отверстием

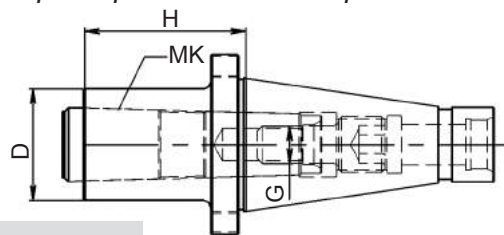

Обозначение	Размеры, мм				
	SK	МК	D	H	G
TH-SK40...MG...H					
TH-SK40MG1H050	40	1	25	50	M 6
TH-SK40MG2H050	40	2	32	50	M 10
TH-SK40MG3H065	40	3	40	65	M 12
TH-SK40MG4H095	40	4	48	95	M 16
TH-SK50...MG...H					
TH-SK50MG1H060	50	1	25	60	M 6
TH-SK50MG2H060	50	2	32	60	M 10
TH-SK50MG3H065	50	3	40	65	M 12
TH-SK50MG4H065	50	4	48	65	M 16
TH-SK50MG5H120	50	5	63	120	M 20

Втулки переходные 7/24 DIN 2080 для сверл с конусом Морзе с лапкой

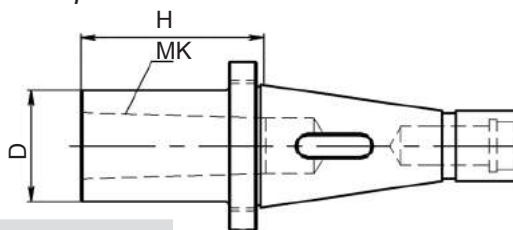

Обозначение	Размеры, мм			
	SK	МК	D	H
TH-SK40...ML...H				
TH-SK40ML1H050	40	1	25	50
TH-SK40ML2H050	40	2	32	50
TH-SK40ML3H065	40	3	40	65
TH-SK40ML4H095	40	4	48	95
TH-SK50...ML...H				
TH-SK50ML1H045	50	1	25	45
TH-SK50ML2H050	50	2	32	50
TH-SK50ML3H065	50	3	40	65
TH-SK50ML4H070	50	4	48	70
TH-SK50ML5H105	50	5	63	105

Втулки переходные с 7/24 DIN 2080 на 7/24 DIN 2080, DIN 69871, MAS BT 403

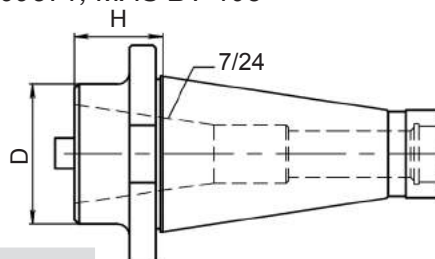
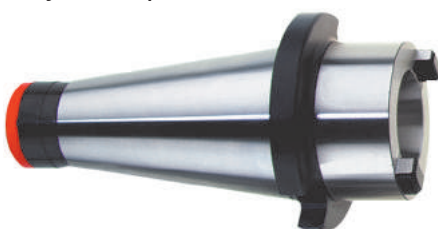

Обозначение	Размеры, мм			
	SK	7/24	D	H
TH-SK50...H				
TH-SK50SK40H050	50	SK40	70	50
TH-SK50NC40H050	50	NC40	70	50
TH-SK50BT40H050	50	BT40	70	50

Патроны сверлильные высокоточные 7/24 DIN 2080

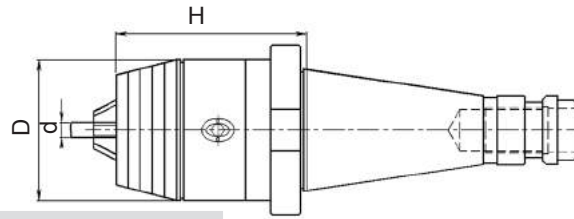

Обозначение	Размеры, мм			
	SK	d	D	H
TH-SK40...D...H				
TH-SK40D08H062	40	0,5-8	36	62
TH-SK40D13H083	40	1-13	50	83
TH-SK40D16H088	40	2,5-16	57	88
TH-SK50...D...H				
TH-SK50D13H110	50	1-13	50	110
TH-SK50D16H115	50	2,5-16	57	115

Патроны цанговые 7/24 DIN 2080 системы OZ

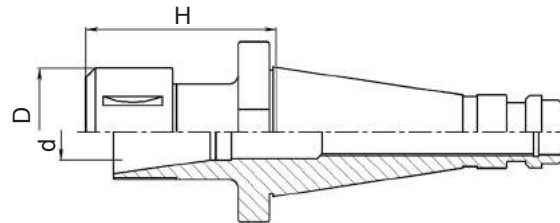

Обозначение	Размеры, мм				Цанга
	SK	d	D	H	
TH-SK40...Z...H					
TH-SK40Z16H070	40	2-16	43	70	OZ 16
TH-SK40Z25H070	40	2-25	60	70	OZ 25
TH-SK40Z25H120	40	2-25	60	120	OZ 25
TH-SK40Z32H095	40	3-32	72	95	OZ 32
TH-SK50...Z...H					
TH-SK50Z25H070	50	2-25	60	70	OZ 25
TH-SK50Z32H080	50	3-32	72	80	OZ 32
TH-SK50Z32H120	50	3-32	72	120	OZ 32

Выбор цанги

стр. 500

Патроны резьбонарезные 7/24 DIN 2080

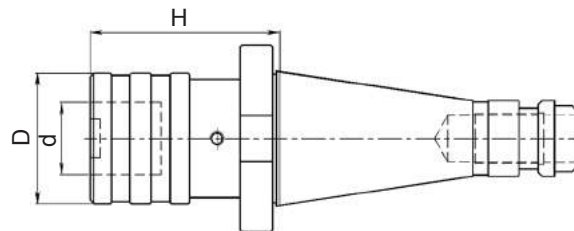
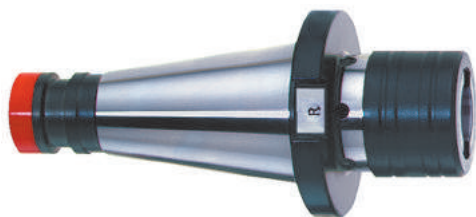

Обозначение	Размеры, мм				Размер	Резьба
	SK	d	D	H		
TH-SK40...M-M						
TH-SK40M3-M12	40	19	38	53	1	M3-M12
TH-SK40M8-M20	40	31	55	77	2	M8-M20
TH-SK40M14-M32	40	48	79	118	3	M14-M32
TH-SK50...M-M						
TH-SK50M3-M12	50	19	38	57	1	M3-M12
TH-SK50M8-M20	50	31	55	79	2	M8-M20
TH-SK50M14-M32	50	48	78	125	3	M14-M32

Вставки
резьбонарезные

стр. 501

Вспомогательный инструмент СКИФ-М с хвостовиком 7/24 (DIN 69871) для станков с автоматической сменой инструмента

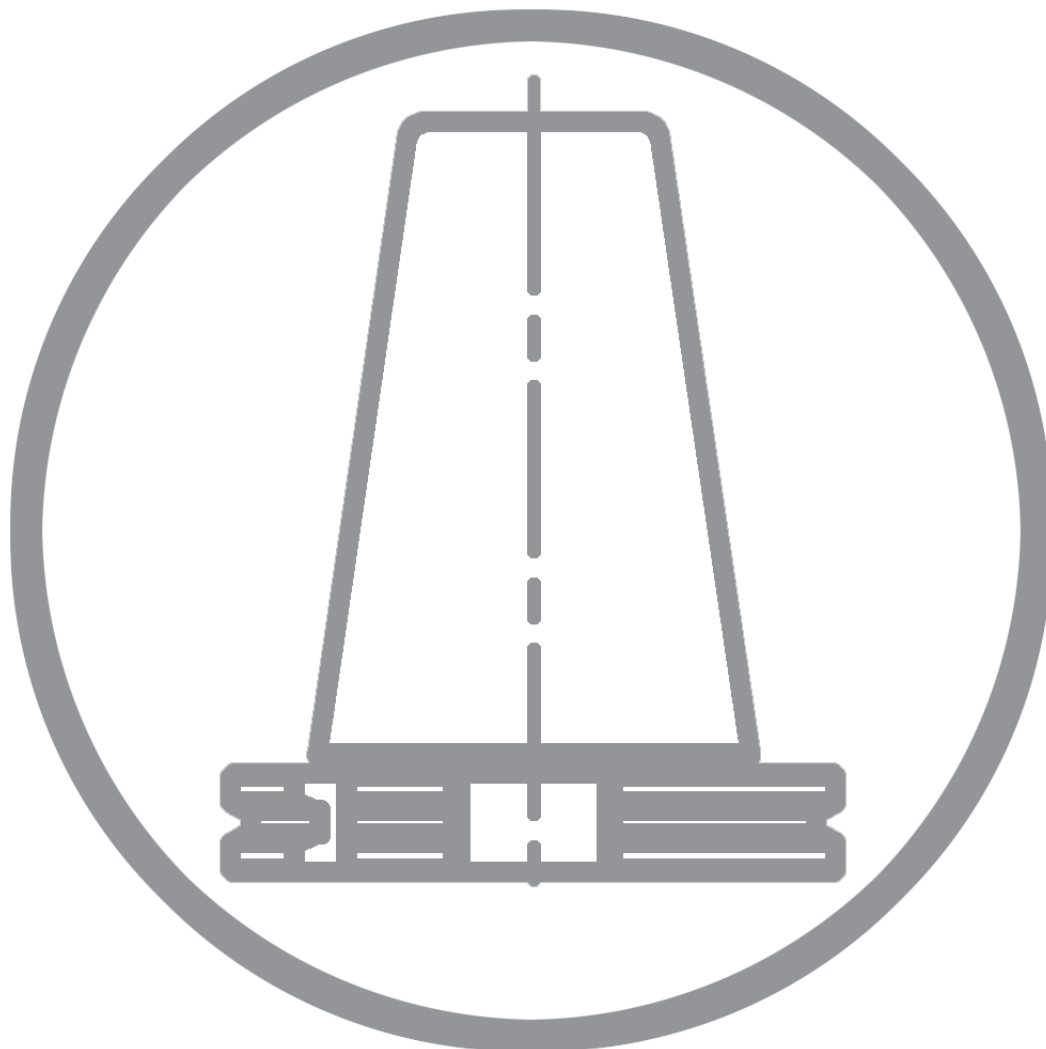

		Стр.
TH-NC...W...H	Оправки 7/24 DIN 69871 для концевых фрез с хвостовиком типа Weldon	458
TH-NC...W...H...AD/B	Оправки 7/24 DIN 69871AD для концевых фрез с хвостовиком типа Weldon с подачей СОЖ	461
TH-NC...S...H	Оправки комбинированные 7/24 DIN 69871 для насадных фрез	462
TH-NC...A,B,C...H	Оправки 7/24 DIN 69871 для торцовых фрез с посадкой форм А, В и С	463
TH-NC...A...H...AD	Оправки 7/24 DIN 69871AD для торцовых фрез с посадкой формы А с внутренней подачей СОЖ	464
TH-NC...A...H...ADG2.5	Оправки балансируемые 7/24 DIN 69871AD для торцовых фрез с посадкой формы А с подачей СОЖ	465
TH-NC...ML...H	Втулки переходные 7/24 DIN 69871 для сверл с конусом Морзе с лапкой	466
TH-NC...MG...H	Втулки переходные 7/24 DIN 69871 для фрез с конусом Морзе с резьбовым отверстием	467
TH-NC...SK,NC,BT...H	Втулки переходные с 7/24 DIN 69871 на 7/24 DIN 2080, DIN 69871, MAS BT 403	468
TH-NC...C...H	Втулки переходные с 7/24 DIN 69871 на DIN 26623-1	468
TH-NC...D...H	Патроны сверлильные высокоточные 7/24 DIN 69871	469
TH-NC...Z...H	Патроны цанговые 7/24 DIN 69871 системы OZ	469
TH-NC...M-M	Патроны резьбонарезные 7/24 DIN 69871	469
TH-NC...T...H	Термопатроны 7/24 DIN 69871	470

Оправки 7/24 DIN 69871 для концевых фрез с хвостовиком типа Weldon

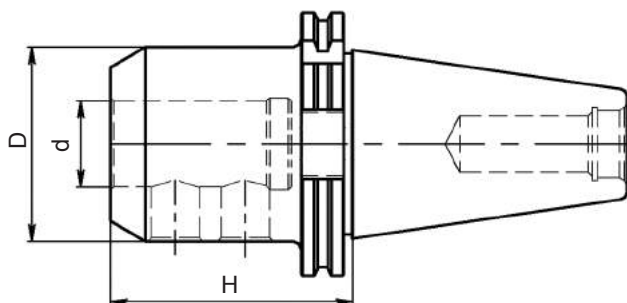
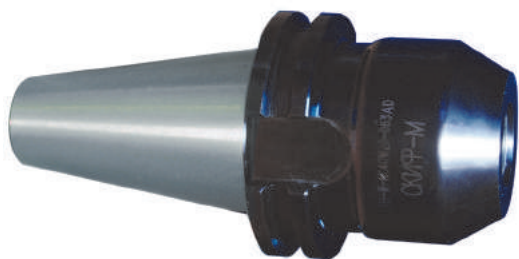

Обозначение	Размеры, мм			
	NC	d	D	H
TH-NC40...W...H				
<i>нормальное исполнение</i>				
TH-NC40W06H050	40	6	25	50
TH-NC40W08H050	40	8	28	50
TH-NC40W10H050	40	10	35	50
TH-NC40W12H050	40	12	42	50
TH-NC40W14H050	40	14	44	50
TH-NC40W16H063	40	16	48	63
TH-NC40W18H063	40	18	50	63
TH-NC40W20H063	40	20	52	63
TH-NC40W22H063	40	22	54	63
TH-NC40W25H100	40	25	65	100
TH-NC40W32H100	40	32	72	100
<i>короткое исполнение</i>				
TH-NC40W16H035	40	16	48	35
TH-NC40W20H035	40	20	52	35
TH-NC40W25H035	40	25	65	35
TH-NC40W32H065	40	32	72	65
<i>удлиненное исполнение</i>				
TH-NC40W06H100	40	6	25	100
TH-NC40W08H100	40	8	28	100
TH-NC40W10H100	40	10	35	100
TH-NC40W12H100	40	12	42	100
TH-NC40W14H100	40	14	44	100
TH-NC40W16H100	40	16	48	100
TH-NC40W18H100	40	18	50	100
TH-NC40W20H100	40	20	52	100
<i>длинное исполнение</i>				
TH-NC40W06H160	40	6	25	160
TH-NC40W08H160	40	8	28	160
TH-NC40W10H160	40	10	35	160
TH-NC40W12H160	40	12	42	160
TH-NC40W14H160	40	14	44	160
TH-NC40W16H160	40	16	48	160
TH-NC40W18H160	40	18	50	160
TH-NC40W20H160	40	20	52	160
TH-NC40W25H160	40	25	65	160
TH-NC40W32H160	40	32	72	160

Винт крепления "Weldon"

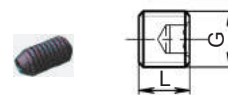

d, мм	G, мм	L, мм
6	M 6	10
8	M 8	10
10	M 10	12
12	M 12	16
14	M 12	16
16	M 14	16
18	M 14	16
20	M 16	16
22	M 16	16
25	M 18x2	20
32	M 20x2	20
40	M 20x2	25
50	M 24x2	25

Обозначение	Размеры, мм			
	NC	d	D	H
TH-NC40...W...H				
<i>особо длинное исполнение</i>				
TH-NC40W06H200	40	6	25	200
TH-NC40W08H200	40	8	28	200
TH-NC40W10H200	40	10	35	200
TH-NC40W12H200	40	12	42	200
TH-NC40W14H200	40	14	44	200
TH-NC40W16H200	40	16	48	200
TH-NC40W18H200	40	18	50	200
TH-NC40W20H200	40	20	52	200
TH-NC40W25H200	40	25	65	200
TH-NC40W32H200	40	32	72	200
<i>сверхдлинное исполнение</i>				
TH-NC40W08H250	40	8	28	250
TH-NC40W10H250	40	10	35	250
TH-NC40W12H250	40	12	42	250
TH-NC40W16H250	40	16	48	250
TH-NC40W20H250	40	20	52	250
TH-NC40W25H250	40	25	65	250
TH-NC40W32H250	40	32	72	250

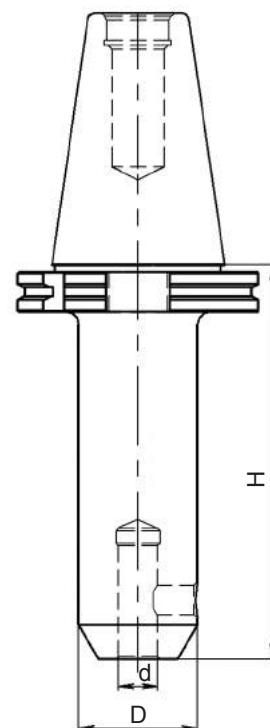

Обозначение	Размеры, мм			
	NC	d	D	H
TH-NC50...W...H				
<i>нормальное исполнение</i>				
TH-NC50W06H063	50	6	25	63
TH-NC50W08H063	50	8	28	63
TH-NC50W10H063	50	10	35	63
TH-NC50W12H063	50	12	42	63
TH-NC50W14H063	50	14	44	63
TH-NC50W16H063	50	16	48	63
TH-NC50W18H063	50	18	50	63
TH-NC50W20H063	50	20	52	63
TH-NC50W22H063	50	22	54	63
TH-NC50W25H080	50	25	65	80
TH-NC50W32H090	50	32	72	90
TH-NC50W32H100	50	32	72	100
TH-NC50W40H090	50	40	80	90
TH-NC50W40H120	50	40	80	120
TH-NC50W50H100	50	50	100	100
TH-NC50W50H130	50	50	100	130
<i>короткое исполнение</i>				
TH-NC50W20H035	40	20	52	35
TH-NC50W25H035	40	25	65	35
TH-NC50W32H065	40	32	72	65

**Винт
крепления "Weldon"**

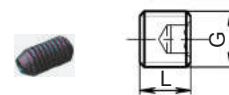

d, мм	G, мм	L, мм
6	M 6	10
8	M 8	10
10	M 10	12
12	M 12	16
14	M 12	16
16	M 14	16
18	M 14	16
20	M 16	16
22	M 16	16
25	M 18x2	20
32	M 20x2	20
40	M 20x2	25
50	M 24x2	25

Обозначение	Размеры, мм			
	NC	d	D	H
TH-NC50...W...H				
<i>удлиненное исполнение</i>				
TH-NC50W06H100	50	6	25	100
TH-NC50W08H100	50	8	28	100
TH-NC50W10H100	50	10	35	100
TH-NC50W12H100	50	12	42	100
TH-NC50W14H100	50	14	44	100
TH-NC50W16H100	50	16	48	100
TH-NC50W18H100	50	18	50	100
TH-NC50W20H100	50	20	52	100
<i>длинное исполнение</i>				
TH-NC50W06H160	50	6	25	160
TH-NC50W08H160	50	8	28	160
TH-NC50W10H160	50	10	35	160
TH-NC50W12H160	50	12	42	160
TH-NC50W16H160	50	16	48	160
TH-NC50W18H160	50	18	50	160
TH-NC50W20H160	50	20	52	160
TH-NC50W25H160	50	25	65	160
TH-NC50W32H160	50	32	72	160
<i>особо длинное исполнение</i>				
TH-NC50W08H200	50	8	28	200
TH-NC50W10H200	50	10	35	200
TH-NC50W12H200	50	12	42	200
TH-NC50W16H200	50	16	48	200
TH-NC50W18H200	50	18	50	200
TH-NC50W20H200	50	20	52	200
TH-NC50W25H200	50	25	65	200
TH-NC50W32H200	50	32	72	200
<i>сверхдлинное исполнение</i>				
TH-NC50W08H250	50	8	28	250
TH-NC50W10H250	50	10	35	250
TH-NC50W12H250	50	12	42	250
TH-NC50W16H250	50	16	48	250
TH-NC50W20H250	50	20	52	250
TH-NC50W25H250	50	25	65	250

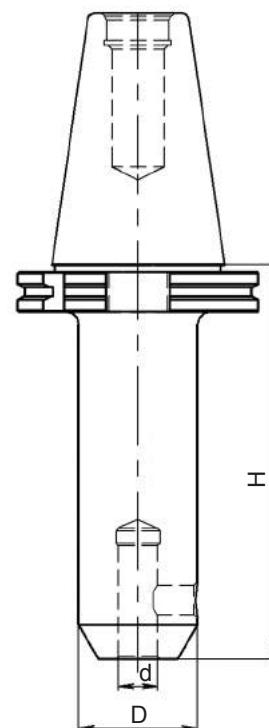
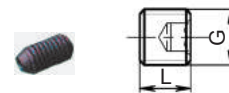
**Винт
крепления "Weldon"**

d, мм	G, мм	L, мм
6	M 6	10
8	M 8	10
10	M 10	12
12	M 12	16
14	M 12	16
16	M 14	16
18	M 14	16
20	M 16	16
22	M 16	16
25	M 18x2	20
32	M 20x2	20
40	M 20x2	25
50	M 24x2	25

Оправки 7/24 DIN 69871AD для концевых фрез с хвостовиком типа Weldon с подачей СОЖ через центральное отверстие в хвостовике

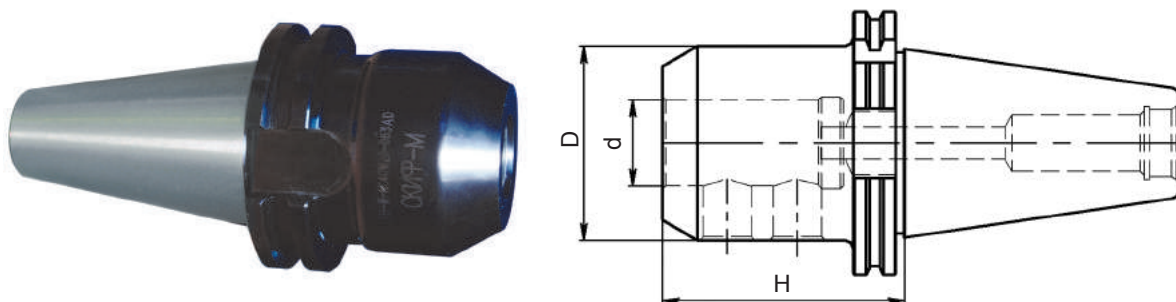

Обозначение	Размеры, мм			
	NC	d	D	H
TH-NC40...W...H...AD	<i>нормальное исполнение</i>			
TH-NC40W16H063AD	40	16	48	63
TH-NC40W20H063AD	40	20	52	63
TH-NC40W25H100AD	40	25	65	100
TH-NC40W32H100AD	40	32	72	100
TH-NC50...W...H...AD	<i>нормальное исполнение</i>			
TH-NC50W16H063AD	50	16	48	63
TH-NC50W20H063AD	50	20	52	63
TH-NC50W25H080AD	50	25	65	80
TH-NC50W32H090AD	50	32	72	90
TH-NC50W32H100AD	50	32	72	100
TH-NC50W32H160AD	50	32	72	160
TH-NC50W40H100AD	50	40	80	100
TH-NC50W50H100AD	50	50	100	100

Оправки 7/24 DIN 69871ADB для концевых фрез с хвостовиком типа Weldon с подачей СОЖ через фланец и центральное отверстие в хвостовике

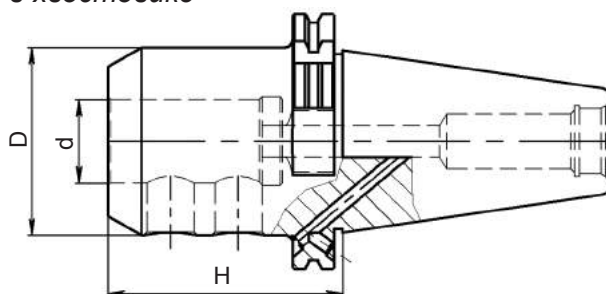

Винт крепления "Weldon"

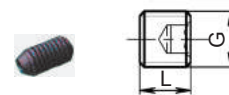

d, мм	G, мм	L, мм
6	M 6	10
8	M 8	10
10	M 10	12
12	M 12	16
14	M 12	16
16	M 14	16
18	M 14	16
20	M 16	16
22	M 16	16
25	M 18x2	20
32	M 20x2	20
40	M 20x2	25
50	M 24x2	25

Обозначение	Размеры, мм			
	NC	d	D	H
TH-NC50...W...H...ADB	<i>нормальное исполнение</i>			
TH-NC50W32H090ADB	50	32	72	90
TH-NC50W32H100ADB	50	32	72	100
TH-NC50W40H090ADB	50	40	80	90
TH-NC50W40H120ADB	50	40	80	120
TH-NC50W50H100ADB	50	50	100	100
TH-NC50W50H130ADB	50	50	100	130

Оправки комбинированные 7/24 DIN 69871 для насадных фрез

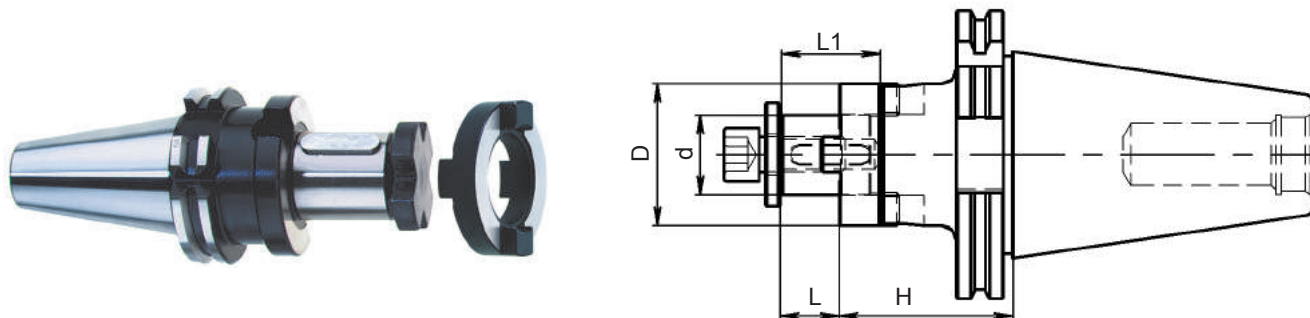

Обозначение	Размеры, мм					
	NC	d	D	H	L	L1
TH-NC40...S...H						
TH-NC40S16H055	40	16	32	55	17	27
TH-NC40S16H100	40	16	32	100	17	27
TH-NC40S16H160	40	16	32	160	17	27
TH-NC40S22H055	40	22	40	55	19	31
TH-NC40S22H100	40	22	40	100	19	31
TH-NC40S22H160	40	22	40	160	19	31
TH-NC40S27H062	40	27	48	62	21	33
TH-NC40S27H100	40	27	48	100	21	33
TH-NC40S27H1060	40	27	48	160	21	33
TH-NC40S32H069	40	32	58	96	24	38
TH-NC40S32H100	40	32	58	100	24	38
TH-NC40S32H160	40	32	58	160	24	38
TH-NC40S40H060	40	40	70	60	27	41
TH-NC40S40H100	40	40	70	100	27	41
TH-NC40S40H160	40	40	70	160	27	41
TH-NC50...S...H						
TH-NC50S16H055	50	16	32	55	17	27
TH-NC50S16H100	50	16	32	100	17	27
TH-NC50S16H160	50	16	32	160	17	27
TH-NC50S22H055	50	22	40	55	19	31
TH-NC50S22H100	50	22	40	100	19	31
TH-NC50S22H160	50	22	40	160	19	31
TH-NC50S27H055	50	27	48	55	21	33
TH-NC50S27H100	50	27	48	100	21	33
TH-NC50S27H160	50	27	48	160	21	33
TH-NC50S32H055	50	32	58	55	24	38
TH-NC50S32H100	50	32	58	100	24	38
TH-NC50S32H160	50	32	58	160	24	38
TH-NC50S40H055	50	40	70	55	27	41
TH-NC50S40H100	50	40	70	100	27	41
TH-NC50S40H160	50	40	70	160	27	41
TH-NC50S50H070	50	50	90	70	30	46
TH-NC50S60H082	50	60	110	82	36	52

Оправки 7/24 DIN 69871 для торцовых фрез с посадкой форм А, В и С

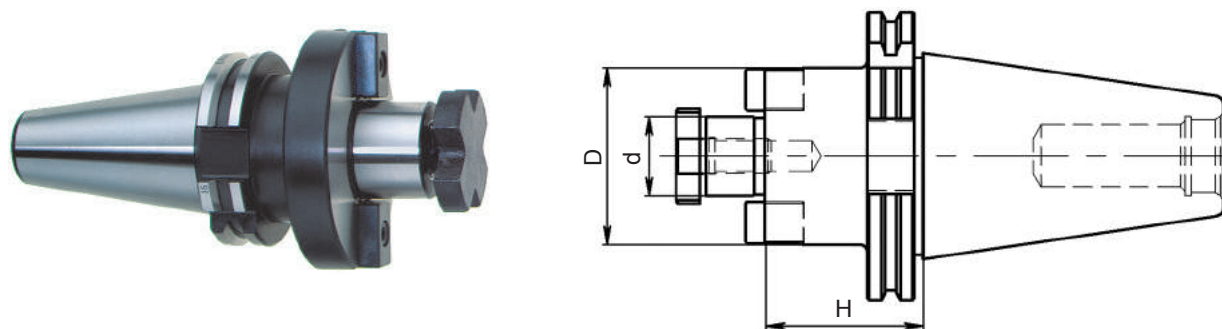

Обозначение	Размеры, мм			
	NC	d	D	H
TH-NC40...A,B,C...H				
TH-NC40A16H035	40	16	40	35
TH-NC40A16H100	40	16	40	100
TH-NC40A16H160	40	16	40	160
TH-NC40A22H035	40	22	48	35
TH-NC40A22H050	40	22	48	50
TH-NC40A22H100	40	22	48	100
TH-NC40A22H160	40	22	48	160
TH-NC40B27H035	40	27	60	35
TH-NC40B27H050	40	27	60	50
TH-NC40B27H100	40	27	60	100
TH-NC40B27H160	40	27	60	160
TH-NC40B32H055	40	32	78	55
TH-NC40B32H100	40	32	78	100
TH-NC40B32H160	40	32	78	160
TH-NC40C40H060	40	40	89	60
TH-NC40C40H100	40	40	89	100
TH-NC50...A,B,C...H				
TH-NC50A16H045	50	16	38	45
TH-NC50A16H100	50	16	38	100
TH-NC50A16H160	50	16	38	160
TH-NC50A22H035	50	22	48	35
TH-NC50A22H055	50	22	48	55
TH-NC50A22H100	50	22	48	100
TH-NC50A22H160	50	22	46	160
TH-NC50A22H200	50	22	46	200
TH-NC50B27H035	50	27	58	35
TH-NC50B27H055	50	27	58	55
TH-NC50B27H100	50	27	58	100
TH-NC50B27H160	50	27	55	160
TH-NC50B32H035	50	32	78	35
TH-NC50B32H055	50	32	78	55
TH-NC50B32H100	50	32	78	100
TH-NC50B32H160	50	32	66	160
TH-NC50B40H055	50	40	72	55
TH-NC50C40H050	50	40	89	50
TH-NC50C60H082	50	60	130	82

Оправки 7/24 DIN 69871AD для торцовых фрез с посадкой формы А с внутренней подачей СОЖ

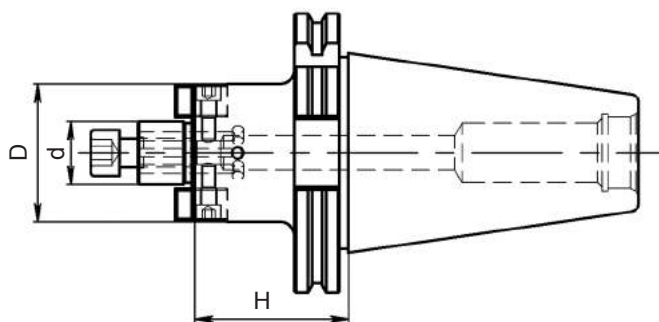

Обозначение	Размеры, мм			
	NC	d	D	H
TH-NC40...A...H...AD				
TH-NC40A16H035AD	40	16	40	35
TH-NC40A16H100AD	40	16	40	100
TH-NC40A22H035AD	40	22	48	35
TH-NC40A22H050AD	40	22	48	50
TH-NC40A22H100AD	40	22	48	100
TH-NC40A27H035AD	40	27	60	35
TH-NC40A27H050AD	40	27	60	50
TH-NC40A27H100AD	40	27	60	100
TH-NC40A32H055AD	40	32	78	55
TH-NC40A32H100AD	40	32	78	100
TH-NC40A40H060AD	40	40	89	60
TH-NC50...A...H...AD				
TH-NC50A22H035AD	50	22	48	35
TH-NC50A22H055AD	50	22	48	55
TH-NC50A22H100AD	50	22	48	100
TH-NC50A27H035AD	50	27	60	35
TH-NC50A27H055AD	50	27	60	55
TH-NC50A27H100AD	50	27	60	100
TH-NC50A32H055AD	50	32	78	55
TH-NC50A32H100AD	50	32	78	100
TH-NC50A40H055AD	50	40	89	55

Оправки балансируемые 7/24 DIN 69871AD для торцовых фрез с посадкой формы А с внутренней подачей СОЖ

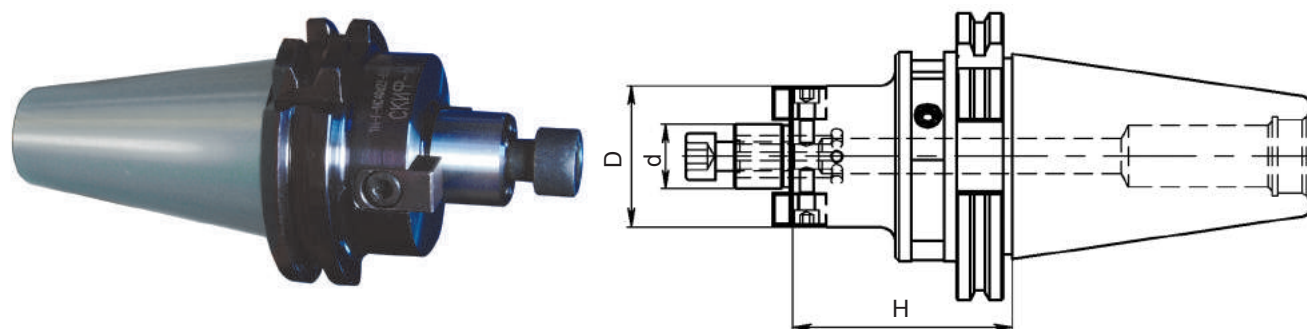

Обозначение	Размеры, мм			
	NC	d	D	H
TH-NC40...A...H...ADG2.5 балансируемые $n_{max}=20\ 000$ об/мин G2.5				
TH-NC40A16H045ADG2.5	40	16	40	45
TH-NC40A16H100ADG2.5	40	16	40	100
TH-NC40A22H050ADG2.5	40	22	48	50
TH-NC40A22H100ADG2.5	40	22	48	100
TH-NC40A27H055ADG2.5	40	27	60	55
TH-NC40A27H100ADG2.5	40	27	60	100
TH-NC40A32H055ADG2.5	40	32	78	55
TH-NC40A32H100ADG2.5	40	32	78	100
TH-NC40A40H060ADG2.5	40	40	89	60
TH-NC50...A...H...ADG2.5 балансируемые $n_{max}=20\ 000$ об/мин G2.5				
TH-NC50A16H045ADG2.5	50	16	40	45
TH-NC50A16H100ADG2.5	50	16	40	100
TH-NC50A22H055ADG2.5	50	22	48	55
TH-NC50A22H100ADG2.5	50	22	48	100
TH-NC50A27H055ADG2.5	50	27	60	55
TH-NC50A27H100ADG2.5	50	27	60	100
TH-NC50A32H055ADG2.5	50	32	78	55
TH-NC50A32H100ADG2.5	50	32	78	100
TH-NC50A40H060ADG2.5	50	40	89	60

Балансировочный элемент



HSK63 B510805
HSK100 B840805

Винт балансировки



H600500-30

Ключ балансировки



7003H

Втулки переходные 7/24 DIN 69871 для сверл с конусом Морзе с лапкой

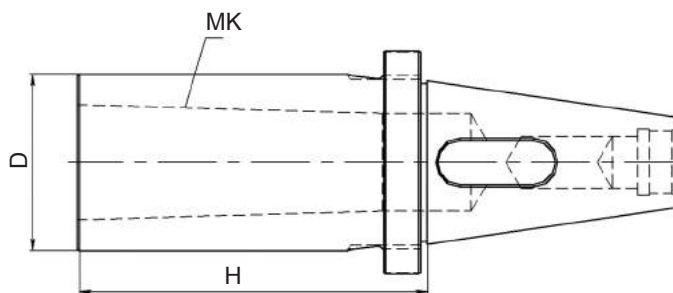

Обозначение	Размеры, мм			
	NC	МК	D	H
TH-NC40...ML...H				
TH-NC40ML1H050	40	1	25	50
TH-NC40ML2H050	40	2	32	50
TH-NC40ML2H117	40	2	32	117
TH-NC40ML2H150	40	2	32	150
TH-NC40ML2H200	40	2	32	200
TH-NC40ML3H070	40	3	40	70
TH-NC40ML3H133	40	3	40	133
TH-NC40ML3H200	40	3	40	200
TH-NC40ML4H095	40	4	48	95
TH-NC40ML4H156	40	4	48	156
TH-NC40ML4H200	40	4	48	200
TH-NC50...ML...H				
TH-NC50ML1H045	50	1	25	45
TH-NC50ML2H050	50	2	32	50
TH-NC50ML2H117	50	2	32	117
TH-NC50ML2H150	50	2	32	150
TH-NC50ML2H200	50	2	32	200
TH-NC50ML3H065	50	3	40	65
TH-NC50ML3H137	50	3	40	137
TH-NC50ML3H150	50	3	40	150
TH-NC50ML3H200	50	3	40	200
TH-NC50ML4H095	50	4	48	95
TH-NC50ML4H167	50	4	48	167
TH-NC50ML4H200	50	4	48	200
TH-NC50ML4H300	50	4	48	300
TH-NC50ML5H105	50	5	63	105
TH-NC50ML5H150	50	5	63	150
TH-NC50ML5H197	50	5	63	197
TH-NC50ML5H300	50	5	63	300

Втулки переходные 7/24 DIN 69871 для фрез с конусом Морзе с резьбовым отверстием

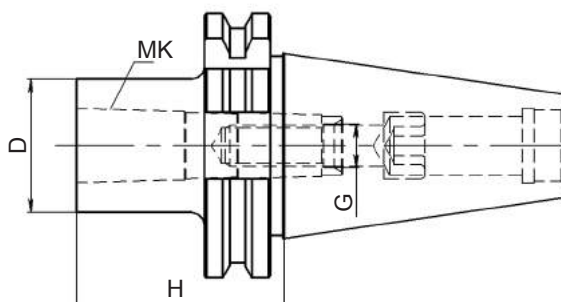

Обозначение	Размеры, мм				
	NC	МК	D	H	G
TH-NC40...MG...H					
TH-NC40MG1H050	40	1	25	50	M 6
TH-NC40MG1H100	40	1	25	100	M 6
TH-NC40MG2H050	40	2	32	50	M 10
TH-NC40MG2H100	40	2	32	100	M 10
TH-NC40MG3H070	40	3	40	70	M 12
TH-NC40MG3H100	40	3	40	100	M 12
TH-NC40MG3H200	40	3	40	200	M 12
TH-NC40MG4H095	40	4	48	95	M 16
TH-NC40MG4H150	40	4	48	150	M 16
TH-NC40MG4H200	40	4	48	200	M 16
TH-NC50...MG...H					
TH-NC50MG1H045	50	1	25	45	M 6
TH-NC50MG2H060	50	2	32	60	M 10
TH-NC50MG3H065	50	3	40	65	M 12
TH-NC50MG4H095	50	4	48	95	M 16
TH-NC50MG4H150	50	4	48	150	M 16
TH-NC50MG4H200	50	4	48	200	M 16
TH-NC50MG4H300	50	4	48	300	M 16
TH-NC50MG5H105	50	5	63	105	M 20
TH-NC50MG5H150	50	5	63	150	M 20
TH-NC50MG5H200	50	5	63	200	M 20
TH-NC50MG5H300	50	5	63	300	M 20

Втулки переходные с 7/24 DIN 69871 на 7/24 DIN 2080, DIN 69871, MAS BT 403

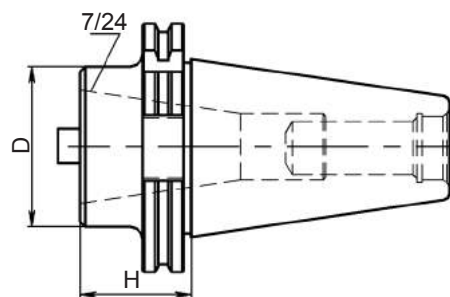

Обозначение	Размеры, мм			
	NC	7/24	D	H
TH-NC50...H				
TH-NC50SK40H050	50	SK40	70	50
TH-NC50NC40H050	50	NC40	70	50
TH-NC50BT40H050	50	BT40	70	50

Втулки переходные с 7/24 DIN 69871 на DIN 26623-1

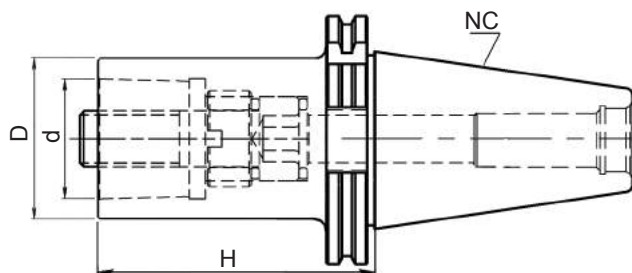
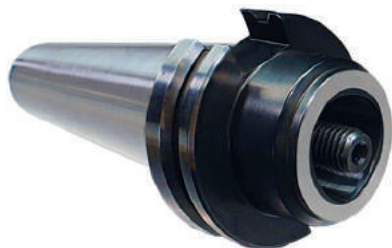

Обозначение	Размеры, мм			
	NC	d	D	H
TH-NC40C...H				
TH-NC40C04H030	40	C04	40	30
TH-NC50C...H				
TH-NC50C04H030	50	C04	40	30
TH-NC50C05H030	50	C05	50	30
TH-NC50C05H110	50	C05	50	110
TH-NC50C06H050	50	C06	63	50
TH-NC50C06H080	50	C06	63	80
TH-NC50C08H070	50	C08	80	70

Патроны сверлильные высокоточные 7/24 DIN 69871

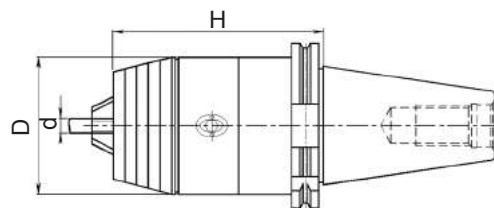

Обозначение	Размеры, мм			
	NC	d	D	H
TH-NC40...D...H				
TH-NC40D08H076	40	0,5-8	36	76
TH-NC40D13H090	40	1-13	50	90
TH-NC40D16H095	40	3-16	57	95
TH-NC50...D...H				
TH-NC50D13H106	50	1-13	50	106
TH-NC50D16H111	50	3-16	57	111

Патроны цанговые 7/24 DIN 69871 системы OZ

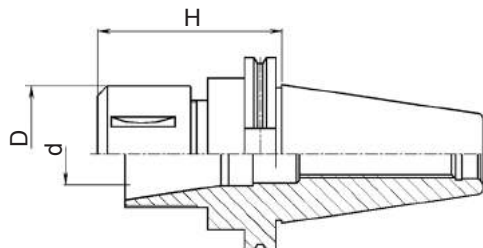

Обозначение	Размеры, мм				Цанга
	NC	d	D	H	
TH-NC40...Z...H					
TH-NC40Z16H070	40	2-16	43	70	OZ 16
TH-NC40Z25H070	40	2-25	60	70	OZ 25
TH-NC40Z25H100	40	2-25	60	100	OZ 25
TH-NC40Z32H090	40	3-32	72	90	OZ 32
TH-NC50...Z...H					
TH-NC50Z25H070	50	2-25	60	70	OZ 25
TH-NC50Z32H080	50	3-32	72	80	OZ 32
TH-NC50Z32H120	50	3-32	72	120	OZ 32

Выбор цанги стр. 500

Патроны резьбонарезные 7/24 DIN 69871

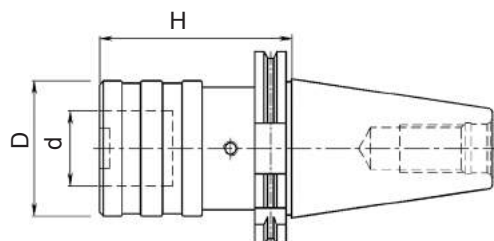

Обозначение	Размеры, мм				Размер	Резьба
	NC	d	D	H		
TH-NC40...M-M						
TH-NC40M3-M12	40	19	38	60	1	M3-M12
TH-NC40M8-M20	40	31	53	100	2	M8-M20
TH-NC40M14-M32	40	48	78	138	3	M14-M32
TH-NC50...M-M						
TH-NC50M3-M12	50	19	38	62	1	M3-M12
TH-NC50M8-M20	50	31	53	83	2	M8-M20
TH-NC50M14-M32	50	48	78	133	3	M14-M32

Вставки резьбонарезные стр. 501

Термопатроны 7/24 DIN 69871

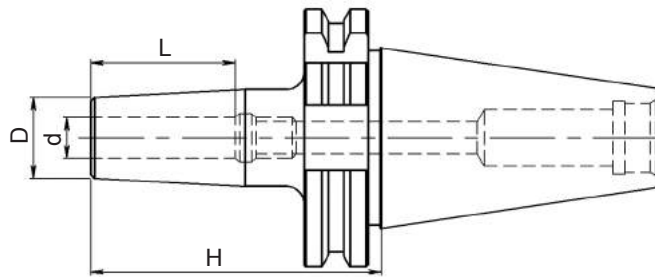
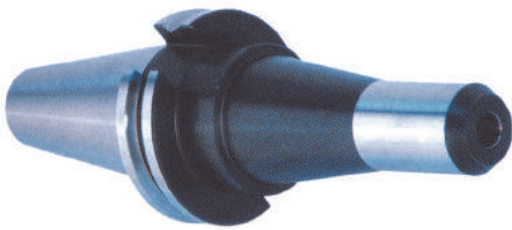

Обозначение	Размеры, мм				
	NC	d	D	L	H
TH-NC40...T...H	<i>нормальное исполнение</i>				
TH-NC40T06H080	40	6	20	36	80
TH-NC40T08H080	40	8	20	36	80
TH-NC40T10H080	40	10	24	42	80
TH-NC40T12H080	40	12	24	47	80
TH-NC40T14H080	40	14	27	47	80
TH-NC40T16H080	40	16	27	50	80
TH-NC40T18H080	40	18	33	50	80
TH-NC40T20H080	40	20	33	52	80
TH-NC40T25H100	40	25	44	58	100
TH-NC40T32H100	40	32	44	58	100

Обозначение	Размеры, мм				
	NC	d	D	L	H
TH-NC40...T...H	<i>длинное исполнение</i>				
TH-NC40T06H160	40	6	20	36	160
TH-NC40T08H160	40	8	20	36	160
TH-NC40T10H160	40	10	24	42	160
TH-NC40T12H160	40	12	24	47	160
TH-NC40T14H160	40	14	27	47	160
TH-NC40T16H160	40	16	27	50	160
TH-NC40T18H160	40	18	33	50	160
TH-NC40T20H160	40	20	33	52	160
TH-NC40T25H160	40	25	44	58	160

Обозначение	Размеры, мм				
	NC	d	D	L	H
TH-NC50...T...H	<i>нормальное исполнение</i>				
TH-NC50T06H080	50	6	20	36	80
TH-NC50T08H080	50	8	20	36	80
TH-NC50T10H080	50	10	24	42	80
TH-NC50T12H080	50	12	24	47	80
TH-NC50T14H080	50	14	27	47	80
TH-NC50T16H080	50	16	27	50	80
TH-NC50T18H080	50	18	33	50	80
TH-NC50T20H080	50	20	33	52	80
TH-NC50T25H100	50	25	44	58	100
TH-NC50T32H100	50	32	44	58	100

Обозначение	Размеры, мм				
	NC	d	D	L	H
TH-NC50...T...H	<i>длинное исполнение</i>				
TH-NC50T06H160	50	6	20	36	160
TH-NC50T08H160	50	8	20	36	160
TH-NC50T10H160	50	10	24	42	160
TH-NC50T12H160	50	12	24	47	160
TH-NC50T14H160	50	14	27	47	160
TH-NC50T16H160	50	16	27	50	160
TH-NC50T18H160	50	18	33	50	160
TH-NC50T20H160	50	20	33	52	160
TH-NC50T25H160	50	25	44	58	160
TH-NC50T32H160	50	32	44	58	160

Вспомогательный инструмент СКИФ-М с хвостовиком 7/24 (MAS BT 403) для станков с автоматической сменой инструмента

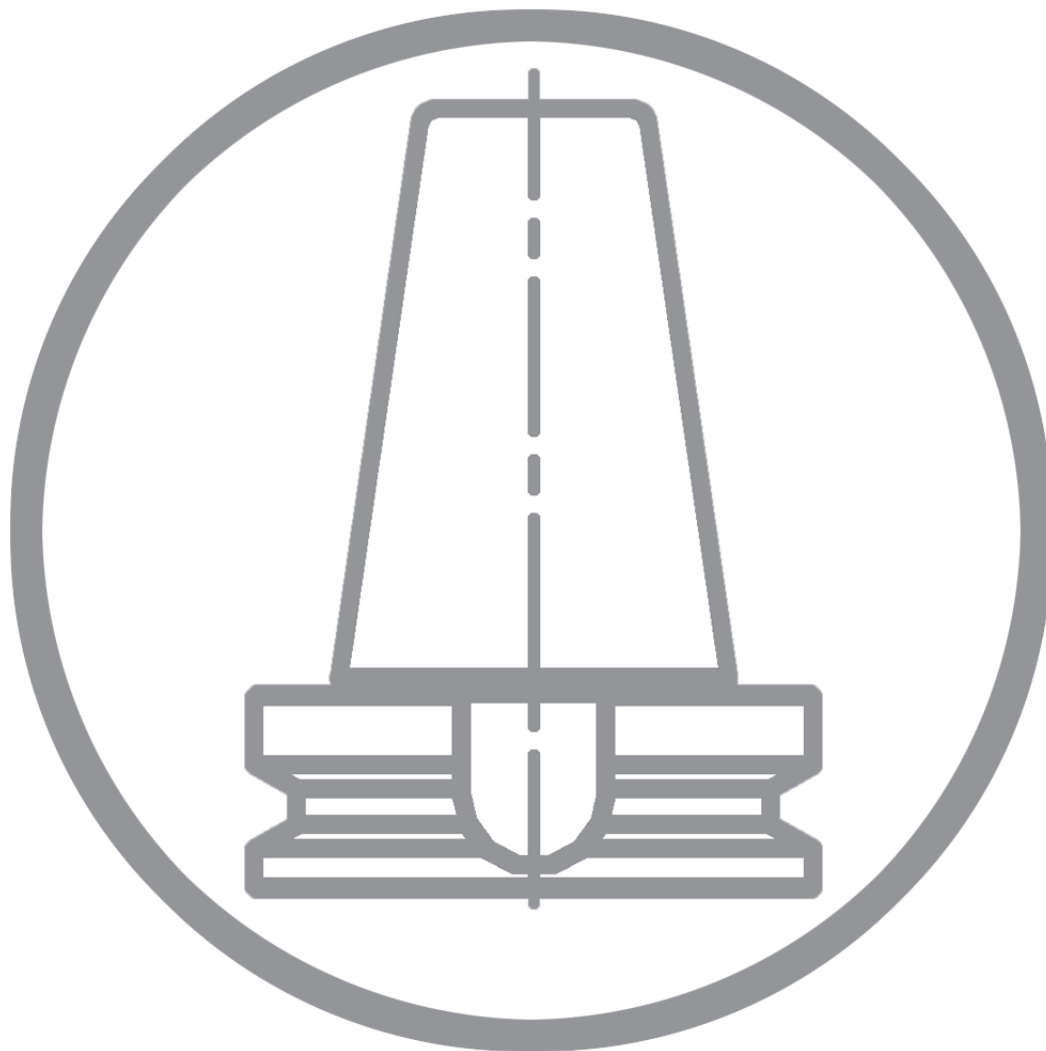

		Стр.
ТН-ВТ...W...H	Оправки 7/24 MAS BT 403 для концевых фрез с хвостовиком типа Weldon	472
ТН-ВТ...S...H	Оправки комбинированные 7/24 MAS BT 403 для насадных фрез	474
ТН-ВТ...А,В,С...H	Оправки 7/24 MAS BT 403 для торцовых фрез с посадкой форм А, В и С	475
ТН-ВТ...А...H...ADG2.5	Оправки балансируемые 7/24 MAS BT 403 для торцовых фрез с посадкой формы А с подачей СОЖ	476
ТН-ВТ...ML...H	Втулки переходные 7/24 MAS BT 403 для сверл с конусом Морзе с лапкой	477
ТН-ВТ...MG...H	Втулки переходные 7/24 MAS BT 403 для фрез с конусом Морзе с резьбовым отверстием	477
ТН-ВТ...SK,NC,ВТ...H	Втулки переходные с 7/24 MAS BT 403 на 7/24 DIN 2080, DIN 69871, MAS BT 403	478
ТН-ВТ...C...H	Втулки переходные с 7/24 MAS BT 403 на DIN 26623-1	478
ТН-ВТ...D...H	Патроны сверлильные высокоточные 7/24 MAS BT 403	479
ТН-ВТ...Z...H	Патроны цанговые 7/24 MAS BT 403 системы OZ	479
ТН-ВТ...М-М	Патроны резьбонарезные 7/24 MAS BT 403	480
ТН-ВТ...Т...H	Термопатроны 7/24 MAS BT 403	480

Оправки 7/24 MAS BT 403 для концевых фрез с хвостовиком типа Weldon

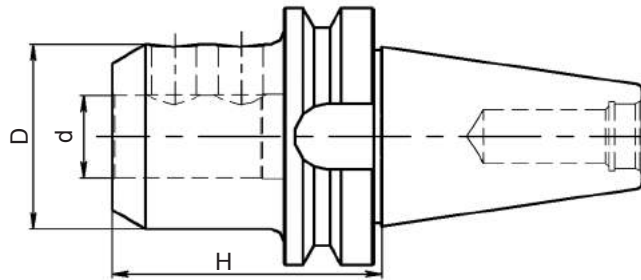

Обозначение	Размеры, мм			
	BT	d	D	H
ТН-ВТ40...W...H <i>короткое исполнение</i>				
ТН-ВТ40W06H050	40	6	25	50
ТН-ВТ40W08H050	40	8	28	50
ТН-ВТ40W10H063	40	10	35	63
ТН-ВТ40W12H063	40	12	42	63
ТН-ВТ40W14H063	40	14	44	63
ТН-ВТ40W16H063	40	16	48	63
ТН-ВТ40W18H063	40	18	50	63
ТН-ВТ40W20H063	40	20	50	63
ТН-ВТ40W25H063	40	25	63	63
ТН-ВТ40...W...H <i>нормальное исполнение</i>				
ТН-ВТ40W06H100	40	6	25	100
ТН-ВТ40W08H100	40	8	28	100
ТН-ВТ40W10H100	40	10	35	100
ТН-ВТ40W12H100	40	12	42	100
ТН-ВТ40W14H100	40	14	44	100
ТН-ВТ40W16H100	40	16	48	100
ТН-ВТ40W18H100	40	18	50	100
ТН-ВТ40W20H100	40	20	52	100
ТН-ВТ40W25H100	40	25	65	100
ТН-ВТ40W32H100	40	32	72	100
ТН-ВТ40W40H120	40	40	80	120
ТН-ВТ40...W...H <i>длинное исполнение</i>				
ТН-ВТ40W06H160	40	6	25	160
ТН-ВТ40W08H160	40	8	28	160
ТН-ВТ40W10H160	40	10	35	160
ТН-ВТ40W12H160	40	12	42	160
ТН-ВТ40W16H160	40	16	48	160
ТН-ВТ40W20H160	40	20	52	160
ТН-ВТ40W25H160	40	25	65	160
ТН-ВТ40W32H160	40	32	72	160

Винт
крепления "Weldon"

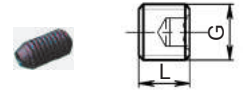

d, мм	G, мм	L, мм
6	M 6	10
8	M 8	10
10	M 10	12
12	M 12	16
14	M 12	16
16	M 14	16
18	M 14	16
20	M 16	16
22	M 16	16
25	M 18x2	20
32	M 20x2	20
40	M 20x2	25
50	M 24x2	25

Оправки 7/24 MAS BT 403 для концевых фрез с хвостовиком типа Weldon

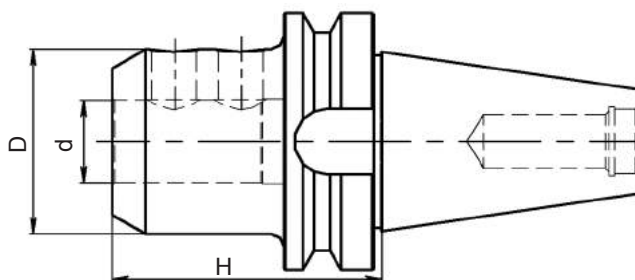

Обозначение	Размеры, мм			
	BT	d	D	H
TH-BT50...W...H <i>нормальное исполнение</i>				
TH-BT50W06H063	50	6	25	63
TH-BT50W08H063	50	8	28	63
TH-BT50W10H063	50	10	35	63
TH-BT50W12H080	50	12	42	80
TH-BT50W14H080	50	14	44	80
TH-BT50W16H080	50	16	48	80
TH-BT50W18H080	50	18	50	80
TH-BT50W20H080	50	20	52	80
TH-BT50W20H100	50	20	52	100
TH-BT50W25H100	50	25	63	100
TH-BT50W32H105	50	32	72	105
TH-BT50W40H120	50	40	80	120
TH-BT50...W...H <i>длинное исполнение</i>				
TH-BT50W06H160	50	6	25	160
TH-BT50W08H160	50	8	28	160
TH-BT50W10H160	50	10	35	160
TH-BT50W12H160	50	12	42	160
TH-BT50W16H160	50	16	48	160
TH-BT50W20H160	50	20	52	160
TH-BT50W25H160	50	25	65	160
TH-BT50W32H160	50	32	72	160

Винт крепления "Weldon"

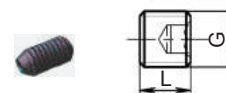

d, мм	G, мм	L, мм
6	M 6	10
8	M 8	10
10	M 10	12
12	M 12	16
14	M 12	16
16	M 14	16
18	M 14	16
20	M 16	16
22	M 16	16
25	M 18x2	20
32	M 20x2	20
40	M 20x2	25
50	M 24x2	25

Оправки комбинированные 7/24 MAS BT 403 для насадных фрез

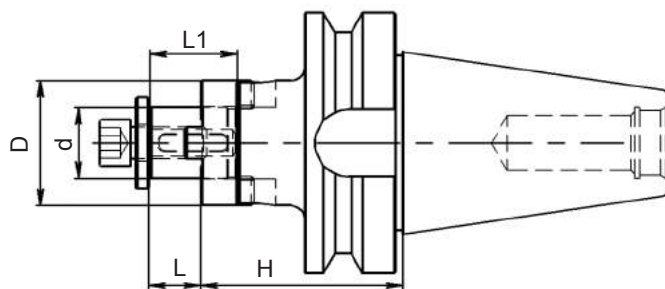
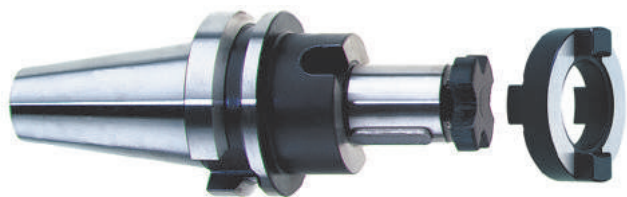

Обозначение	Размеры, мм					
	BT	d	D	H	L	L1
TH-BT40...S...H						
TH-BT40S16H055	40	16	32	55	17	27
TH-BT40S16H100	40	16	32	100	17	27
TH-BT40S16H160	40	16	32	160	17	27
TH-BT40S22H055	40	22	40	55	19	31
TH-BT40S22H100	40	22	40	100	19	31
TH-BT40S22H160	40	22	40	160	19	31
TH-BT40S27H055	40	27	48	55	21	33
TH-BT40S27H160	40	27	48	100	21	33
TH-BT40S27H100	40	27	48	160	21	33
TH-BT40S32H060	40	32	58	60	24	38
TH-BT40S32H100	40	32	58	100	24	38
TH-BT40S32H160	40	32	58	160	24	38
TH-BT40S40H060	40	40	70	60	27	41
TH-BT40S40H100	40	40	70	100	27	41
TH-BT40S40H160	40	40	70	160	27	41
TH-BT50...S...H						
TH-BT50S16H070	50	16	32	70	17	27
TH-BT50S16H100	50	16	32	100	17	27
TH-BT50S16H160	50	16	32	160	17	27
TH-BT50S22H070	50	22	40	70	19	31
TH-BT50S22H100	50	22	40	100	19	31
TH-BT50S22H160	50	22	40	160	19	31
TH-BT50S27H070	50	27	48	70	21	33
TH-BT50S27H100	50	27	48	100	21	33
TH-BT50S27H160	50	27	48	160	21	33
TH-BT50S32H070	50	32	58	70	24	38
TH-BT50S32H100	50	32	58	100	24	38
TH-BT50S32H160	50	32	58	160	24	38
TH-BT50S40H070	50	40	70	70	27	41
TH-BT50S40H100	50	40	70	100	27	41
TH-BT50S40H160	50	40	70	160	27	41
TH-BT50S50H070	50	50	90	70	30	46
TH-BT50S50H100	50	50	90	100	30	46
TH-BT50S50H160	50	50	90	160	30	46

Оправки 7/24 MAS BT 403 для торцовых фрез с посадкой форм А, В и С

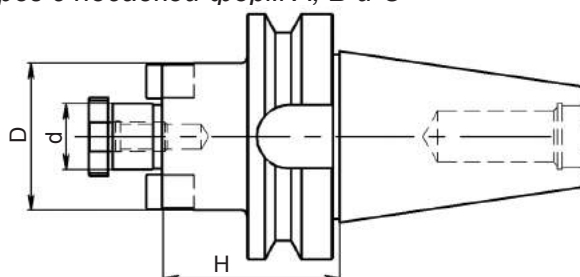

Обозначение	Размеры, мм			
	BT	d	D	H
TH-BT40...A,B,C...H				
				$n_{max} = 8\ 000$ об/мин
TH-BT40A16H040	40	16	40	40
TH-BT40A16H045	40	16	40	45
TH-BT40A16H100	40	16	40	100
TH-BT40A22H045	40	22	48	45
TH-BT40A22H100	40	22	48	100
TH-BT40A22H160	40	22	48	160
TH-BT40B27H045	40	27	60	45
TH-BT40B27H100	40	27	60	100
TH-BT40B32H050	40	32	78	50
TH-BT40B32H100	40	32	78	100
TH-BT40C40H055	40	40	89	55
TH-BT40C40H100	40	40	89	100
TH-BT40C50H080	40	50	129	80

TH-BT50...A,B,C...H				
				$n_{max} = 8\ 000$ об/мин
TH-BT50A16H055	50	16	40	55
TH-BT50A16H100	50	16	40	100
TH-BT50A16H160	50	16	40	160
TH-BT50A22H055	50	22	48	55
TH-BT50A22H100	50	22	48	100
TH-BT50A22H160	50	22	48	160
TH-BT50A22H200	50	22	48	200
TH-BT50B27H055	50	27	60	55
TH-BT50B27H100	50	27	60	100
TH-BT50B27H160	50	27	60	160
TH-BT50B27H200	50	27	60	200
TH-BT50B32H055	50	32	78	55
TH-BT50B32H100	50	32	78	100
TH-BT50B32H160	50	32	78	160
TH-BT50B32H200	50	32	78	200
TH-BT50C40H055	50	40	89	55
TH-BT50C40H100	50	40	89	100
TH-BT50C60H080	50	60	130	80

Балансировочный элемент



HSK63 B510805
HSK100 B840805

Винт балансировки



H600500-30

Ключ балансировки



7003H

Оправки балансируемые 7/24 MAS BT 403 для торцовых фрез с посадкой формы А с внутренней подачей СОЖ

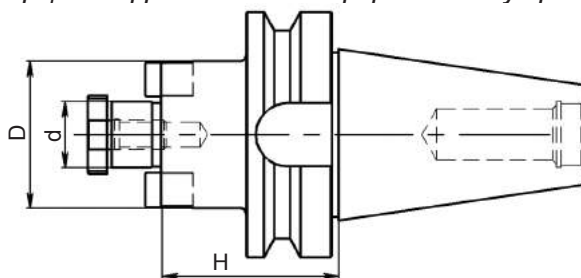
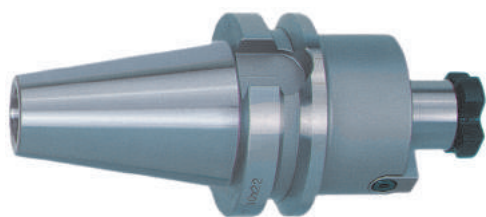

Обозначение	Размеры, мм			
	BT	d	D	H
TH-BT40...A...H...ADG2.5	балансируемые $n_{max}=20\ 000$ об/мин G2.5			
TH-BT40A16H055ADG2.5	40	16	40	55
TH-BT40A16H100ADG2.5	40	16	40	100
TH-BT40A22H060ADG2.5	40	22	48	60
TH-BT40A22H100ADG2.5	40	22	48	100
TH-BT40A27H060ADG2.5	40	27	60	60
TH-BT40A32H065ADG2.5	40	32	78	65
TH-BT40A40H080ADG2.5	40	40	89	80
TH-BT50...A...H...ADG2.5	балансируемые $n_{max}=20\ 000$ об/мин G2.5			
TH-BT50A16H070ADG2.5	50	16	40	70
TH-BT50A22H070ADG2.5	50	22	48	70
TH-BT50A22H100ADG2.5	50	22	48	100
TH-BT50A27H070ADG2.5	50	27	60	70
TH-BT50A27H100ADG2.5	50	27	60	100
TH-BT50A32H070ADG2.5	50	32	78	70
TH-BT50A32H100ADG2.5	50	32	78	100
TH-BT50A40H075ADG2.5	50	40	89	75
TH-BT50A40H100ADG2.5	50	40	89	100

Балансировочный элемент

HSK63 B510805
 HSK100 B840805

Винт балансировки

H600500-30

Ключ балансировки

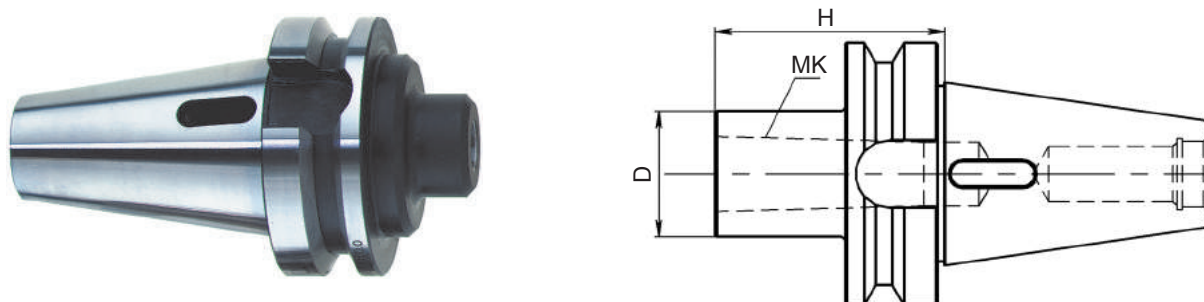

7003H

Втулки переходные 7/24 MAS BT 403 для сверл с конусом Морзе с лапкой

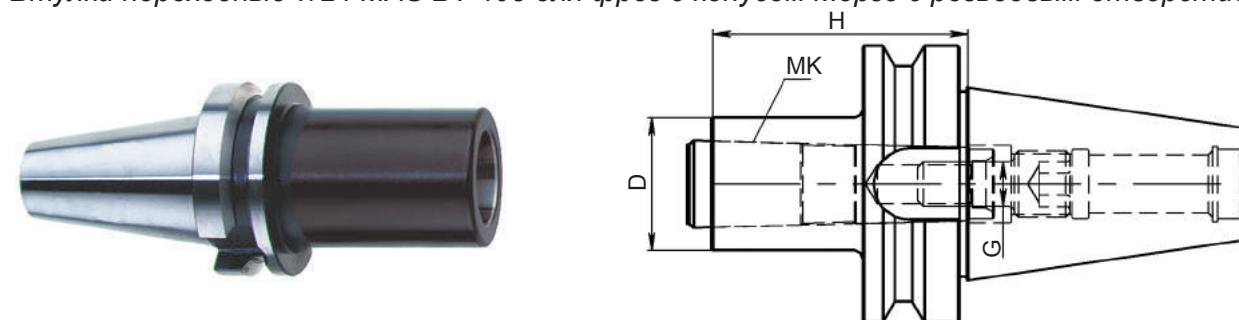

Обозначение	Размеры, мм			
	BT	МК	D	H
TH-BT40...ML...H				
TH-BT40ML1H050	40	1	25	50
TH-BT40ML2H050	40	2	32	50
TH-BT40ML3H070	40	3	40	70
TH-BT40ML4H095	40	4	48	95
TH-BT50...ML...H				
TH-BT50ML1H045	50	1	25	45
TH-BT50ML2H050	50	2	32	50
TH-BT50ML3H065	50	3	40	65
TH-BT50ML4H095	50	4	48	95
TH-BT50ML5H105	50	5	63	105

Втулки переходные 7/24 MAS BT 403 для фрез с конусом Морзе с резьбовым отверстием



Обозначение	Размеры, мм				
	BT	МК	D	H	G
TH-BT40...MG...H					
TH-BT40MG1H050	40	1	25	50	M 6
TH-BT40MG2H050	40	2	32	50	M 10
TH-BT40MG3H070	40	3	40	70	M 12
TH-BT40MG4H095	40	4	48	95	M 16
TH-BT50...MG...H					
TH-BT50MG1H045	50	1	25	45	M 6
TH-BT50MG2H055	50	2	32	55	M 10
TH-BT50MG3H060	50	3	40	60	M 12
TH-BT50MG3H065	50	3	40	65	M 12
TH-BT50MG4H080	50	4	48	80	M 16
TH-BT50MG4H090	50	4	48	90	M 16
TH-BT50MG5H110	50	5	63	110	M 20

Втулки переходные с 7/24 MAS BT 403 на 7/24 DIN 2080, DIN 69871, MAS BT 403

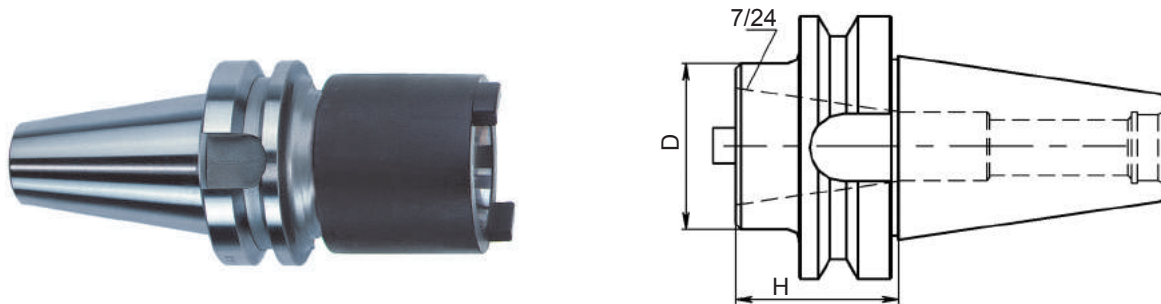

Обозначение	Размеры, мм			
	BT	7/24	D	H
ТН-ВТ50...Н				
ТН-ВТ50SK40Н070	50	SK40	70	70
ТН-ВТ50NC40Н070	50	NC40	70	70
ТН-ВТ50ВТ40Н070	50	ВТ40	70	70

Втулки переходные с 7/24 MAS BT 403 на DIN 26623-1

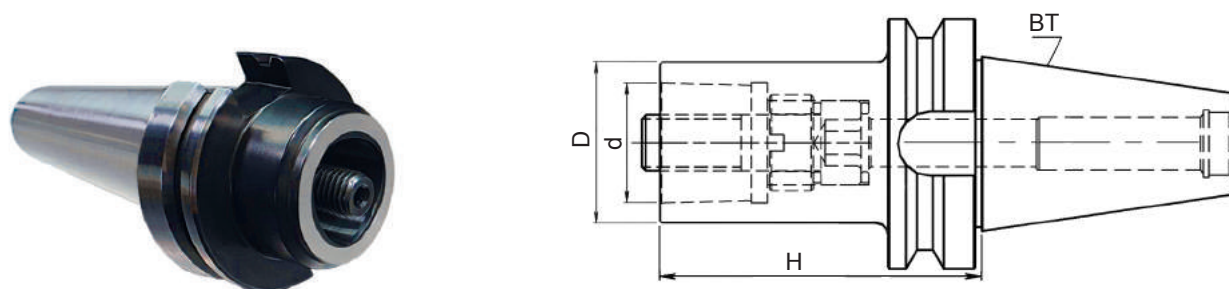

Обозначение	Размеры, мм			
	BT	d	D	H
ТН-ВТ40С...Н				
ТН-ВТ40С04Н030	40	C04	40	30
ТН-ВТ50С...Н				
ТН-ВТ50С04Н070	50	C04	40	70
ТН-ВТ50С05Н040	50	C05	50	40
ТН-ВТ50С06Н050	50	C06	63	50
ТН-ВТ50С06Н090	50	C06	63	90
ТН-ВТ50С08Н070	50	C08	80	70

Патроны сверлильные высокоточные 7/24 MAS BT 403

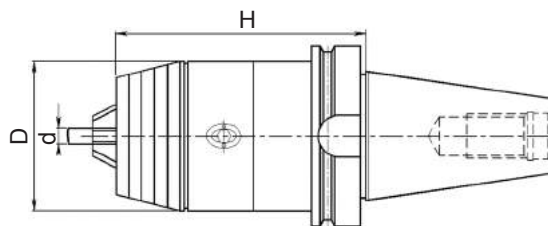

Обозначение	Размеры, мм			
	BT	d	D	H
TH-BT40...D...H				
TH-BT40D08H081	40	0,3-8	36	81
TH-BT40D13H098	40	0,5-13	50	98
TH-BT40D16H103	40	2,5-16	57	103
TH-BT50...D...H				
TH-BT50D13H110	50	1-13	50	110
TH-BT50D16H115	50	3-16	57	115

Патроны цанговые 7/24 MAS BT 403 системы OZ

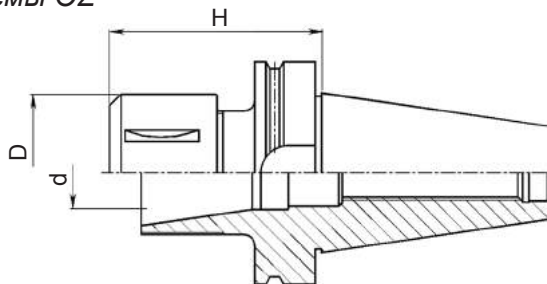
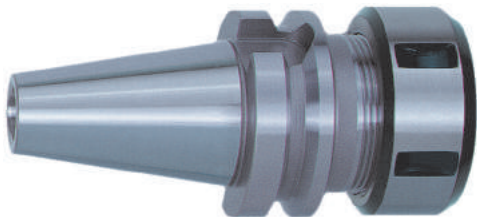

Обозначение	Размеры, мм				Цанга
	BT	d	D	H	
TH-BT40...Z...H					
TH-BT40Z16H070	40	2-16	43	70	OZ 16
TH-BT40Z25H070	40	2-25	60	70	OZ 25
TH-BT40Z25H120	40	2-25	60	120	OZ 25
TH-BT40Z32H090	40	3-32	72	90	OZ 32
TH-BT50...Z...H					
TH-BT50Z25H085	50	2-25	60	85	OZ 25
TH-BT50Z32H090	50	3-32	72	90	OZ 32

Выбор цанги

стр. 500

Патроны резьбонарезные 7/24 MAS BT 403

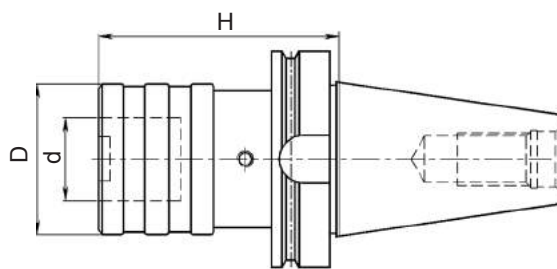

Обозначение	Размеры, мм				Размер	Резьба
	BT	d	D	H		
TH-BT40...M-M						
TH-BT40M3-M12	40	19	38	68	1	M3-M12
TH-BT40M8-M20	40	31	55	93	2	M8-M20
TH-BT40M14-M33	40	48	79	138	3	M14-M33
TH-BT50...M-M						
TH-BT50M3-M12	50	19	38	80	1	M3-M12
TH-BT50M8-M20	50	31	55	102	2	M8-M20
TH-BT50M14-M33	50	48	79	133	3	M14-M33
TH-BT50M22-M48	50	60	98	147	4	M22-M48

Вставки
резьбонарезные

стр. 501

Термопатроны 7/24 MAS BT 403

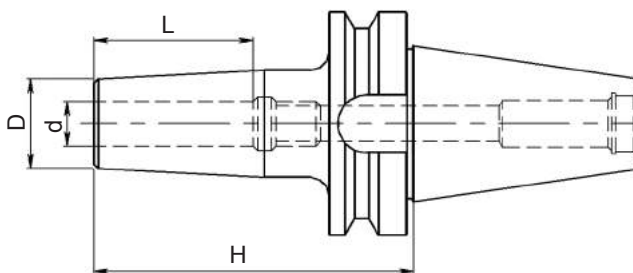
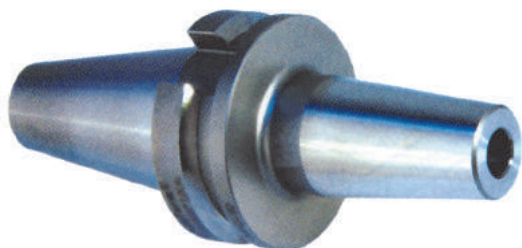

Обозначение	Размеры, мм				
	BT	d	D	L	H
TH-BT40...T...H <i>нормальное исполнение</i>					
TH-BT40T06H090	40	6	20	36	90
TH-BT40T08H090	40	8	20	36	90
TH-BT40T10H090	40	10	24	42	90
TH-BT40T12H090	40	12	24	47	90
TH-BT40T14H090	40	14	27	47	90
TH-BT40T16H090	40	16	27	50	90
TH-BT40T18H090	40	18	33	50	90
TH-BT40T20H090	40	20	33	52	90
TH-BT40T25H100	40	25	44	58	100
TH-BT40T32H100	40	32	44	58	100
TH-BT40...T...H <i>длинное исполнение</i>					
TH-BT40T06H160	40	6	20	36	160
TH-BT40T08H160	40	8	20	36	160
TH-BT40T10H160	40	10	24	42	160
TH-BT40T12H160	40	12	24	47	160
TH-BT40T14H160	40	14	27	47	160
TH-BT40T16H160	40	16	27	50	160
TH-BT40T18H160	40	18	33	50	160
TH-BT40T20H160	40	20	33	52	160
TH-BT40T25H160	40	25	44	58	160

Обозначение	Размеры, мм				
	BT	d	D	L	H
TH-BT50...T...H <i>нормальное исполнение</i>					
TH-BT50T06H100	50	6	20	36	100
TH-BT50T08H100	50	8	20	36	100
TH-BT50T10H100	50	10	24	42	100
TH-BT50T12H100	50	12	24	47	100
TH-BT50T14H100	50	14	27	47	100
TH-BT50T16H100	50	16	27	50	100
TH-BT50T18H100	50	18	33	50	100
TH-BT50T20H100	50	20	33	52	100
TH-BT50T25H110	50	25	44	58	110
TH-BT50T32H110	50	32	44	58	110
TH-BT50...T...H <i>длинное исполнение</i>					
TH-BT50T06H160	50	6	20	36	160
TH-BT50T08H160	50	8	20	36	160
TH-BT50T10H160	50	10	24	42	160
TH-BT50T12H160	50	12	24	47	160
TH-BT50T14H160	50	14	27	47	160
TH-BT50T16H160	50	16	27	50	160
TH-BT50T18H160	50	18	33	50	160
TH-BT50T20H160	50	20	33	52	160
TH-BT50T25H160	50	25	44	58	160
TH-BT50T32H160	50	32	44	58	160

Вспомогательный инструмент СКИФ-М с хвостовиком HSK DIN 69893, форма А



		Стр.
ТН-НА...W...H	Оправки HSK DIN 69893 для концевых фрез с хвостовиком типа Weldon	482
ТН-НА...W...H...AD	Оправки HSK DIN 69893 для концевых фрез с хвостовиком типа Weldon с внутренней подачей СОЖ	484
ТН-НА...А,В,С...H	Оправки HSK DIN 69893 для торцовых фрез с посадкой форм А, В и С	485
ТН-НА...А...H...AD	Оправки HSK DIN 69893 для торцовых фрез с посадкой формы А с внутренней подачей СОЖ	486
ТН-НА...А...H...ADG2.5	Оправки балансируемые HSK DIN 69893 для торцовых фрез с посадкой формы А с подачей СОЖ	487
ТН-НА...ML...H	Втулки переходные HSK DIN 69893 для сверл с конусом Морзе с лапкой	488
ТН-НА...MG...H	Втулки переходные HSK DIN 69893 для фрез с конусом Морзе с резьбовым отверстием	488
ТН-НА...С...H	Втулки переходные с DIN 69893 на DIN 26623-1	489
ТН-НА...D...H	Патроны сверлильные высокоточные HSK DIN 69893	489
ТН-НА...Z...H...G2.5	Патроны цанговые балансируемые HSK DIN 69893 системы OZ	490
ТН-НА...М-М	Патроны резьбонарезные HSK DIN 69893	490
ТН-НА...Т...H	Термопатроны HSK DIN 69893	491

Оправки HSK DIN 69893 для концевых фрез с хвостовиком типа Weldon

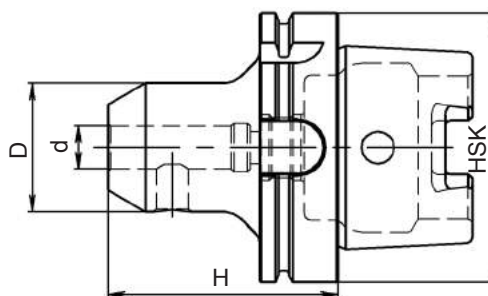

Обозначение	Размеры, мм			
	HSK	d	D	H
TH-HA063...W...H	<i>нормальное исполнение</i>		$n_{max} = 8\ 000$ об/мин	
TH-HA063W06H065	63	6	25	65
TH-HA063W08H065	63	8	28	65
TH-HA063W10H065	63	10	35	65
TH-HA063W12H080	63	12	42	80
TH-HA063W14H080	63	14	44	80
TH-HA063W16H080	63	16	48	80
TH-HA063W18H080	63	18	50	80
TH-HA063W20H080	63	20	52	80
TH-HA063W25H110	63	25	65	110
TH-HA063W32H110	63	32	72	110
TH-HA100...W...H	<i>нормальное исполнение</i>		$n_{max} = 8\ 000$ об/мин	
TH-HA100W06H090	100	6	25	90
TH-HA100W08H090	100	8	28	90
TH-HA100W10H090	100	10	35	90
TH-HA100W12H100	100	12	42	100
TH-HA100W14H100	100	14	44	100
TH-HA100W16H100	100	16	48	100
TH-HA100W18H100	100	18	50	100
TH-HA100W20H110	100	20	52	110
TH-HA100W25H120	100	25	65	120
TH-HA100W32H120	100	32	72	120
TH-HA100W40H120	100	40	80	120
TH-HA125...W...H	<i>нормальное исполнение</i>		$n_{max} = 8\ 000$ об/мин	
TH-HA125W25H110	125	25	65	110
TH-HA125W32H120	125	32	72	120
TH-HA125W40H120	125	40	80	120
TH-HA125W50H130	125	50	100	130

Оправки HSK DIN 69893 для концевых фрез с хвостовиком типа Weldon

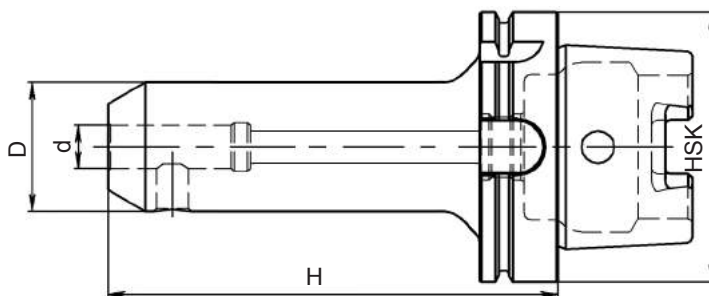

Обозначение	Размеры, мм			
	HSK	d	D	H
ТН-НА063...W...H	<i>длинное исполнение</i>		$n_{max} = 8\ 000$ об/мин	
ТН-НА063W06H140	63	6	25	140
ТН-НА063W08H140	63	8	28	140
ТН-НА063W10H140	63	10	35	140
ТН-НА063W12H140	63	12	42	140
ТН-НА063W14H140	63	14	44	140
ТН-НА063W16H140	63	16	48	140
ТН-НА063W18H140	63	18	50	140
ТН-НА063W20H140	63	20	52	140
ТН-НА100...W...H	<i>длинное исполнение</i>		$n_{max} = 8\ 000$ об/мин	
ТН-НА100W06H160	100	6	25	160
ТН-НА100W08H160	100	8	28	160
ТН-НА100W10H160	100	10	35	160
ТН-НА100W12H160	100	12	42	160
ТН-НА100W14H160	100	16	48	160
ТН-НА100W16H160	100	20	52	160

Винт крепления "Weldon"

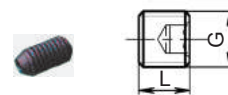

d, мм	G, мм	L, мм
6	M 6	10
8	M 8	10
10	M 10	12
12	M 12	16
14	M 12	16
16	M 14	16
18	M 14	16
20	M 16	16
22	M 16	16
25	M 18x2	20
32	M 20x2	20
40	M 20x2	25
50	M 24x2	25

Оправки HSK DIN 69893 для концевых фрез с хвостовиком типа Weldon с внутренней подачей СОЖ

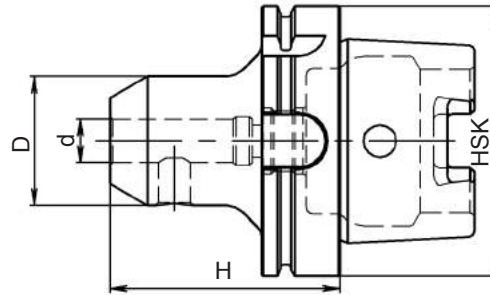

Обозначение	Размеры, мм			
	HSK	d	D	H
TH-HA063...W...H...AD $n_{max} = 8\ 000$ об/мин				
TH-HA063W08H065AD	63	8	28	65
TH-HA063W08H160AD	63	8	28	160
TH-HA063W10H065AD	63	10	35	65
TH-HA063W10H160AD	63	10	35	160
TH-HA063W12H080AD	63	12	42	80
TH-HA063W12H160AD	63	12	42	160
TH-HA063W14H080AD	63	14	44	80
TH-HA063W16H080AD	63	16	48	80
TH-HA063W16H140AD	63	16	48	140
TH-HA063W20H080AD	63	20	52	80
TH-HA063W20H160AD	63	20	52	160
TH-HA063W25H110AD	63	25	65	110
TH-HA063W25H160AD	63	25	65	160
TH-HA063W32H110AD	63	32	72	110
TH-HA100...W...H...AD $n_{max} = 8\ 000$ об/мин				
TH-HA100W08H080AD	100	8	28	80
TH-HA100W08H160AD	100	8	28	160
TH-HA100W10H080AD	100	10	35	80
TH-HA100W10H160AD	100	10	35	160
TH-HA100W12H080AD	100	12	42	80
TH-HA100W12H160AD	100	12	42	160
TH-HA100W14H080AD	100	14	44	80
TH-HA100W16H100AD	100	16	48	100
TH-HA100W16H160AD	100	16	48	160
TH-HA100W20H110AD	100	20	52	110
TH-HA100W20H160AD	100	20	52	160
TH-HA100W25H120AD	100	25	65	120
TH-HA100W32H100AD	100	32	72	100
TH-HA100W32H120AD	100	32	72	120
TH-HA100W40H105AD	100	40	80	105
TH-HA100W40H120AD	100	40	80	120
TH-HA125...W...H...AD $n_{max} = 8\ 000$ об/мин				
TH-HA125W25H110AD	125	25	65	110
TH-HA125W32H120AD	125	32	72	120
TH-HA125W40H120AD	125	40	80	120
TH-HA125W50H130AD	125	50	100	130

Винт крепления "Weldon"

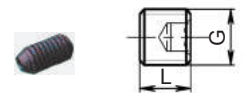

d, мм	G, мм	L, мм
6	M 6	10
8	M 8	10
10	M 10	12
12	M 12	16
14	M 12	16
16	M 14	16
18	M 14	16
20	M 16	16
22	M 16	16
25	M 18x2	20
32	M 20x2	20
40	M 20x2	25
50	M 24x2	25

Оправки HSK DIN 69893 для торцовых фрез с посадкой форм А, В и С

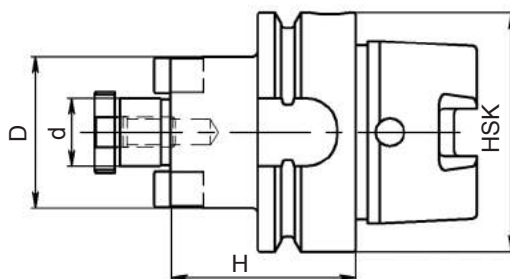

Обозначение	Размеры, мм			
	HSK	d	D	H
ТН-НА063...А,В,С...Н				<i>n_{max} = 8 000 об/мин</i>
ТН-НА063А16Н045	63	16	38	45
ТН-НА063А16Н145	63	16	38	145
ТН-НА063А22Н050	63	22	48	50
ТН-НА063А22Н150	63	22	48	150
ТН-НА063В27Н060	63	27	60	60
ТН-НА063В27Н155	63	27	60	155
ТН-НА063В32Н060	63	32	78	60
ТН-НА063В32Н155	63	32	78	155
ТН-НА063С40Н060	63	40	89	60
ТН-НА063В40Н160	63	40	72	160
ТН-НА100...А,В,С...Н				<i>n_{max} = 8 000 об/мин</i>
ТН-НА100А16Н055	100	16	38	55
ТН-НА100А16Н150	100	16	38	155
ТН-НА100А22Н055	100	22	48	55
ТН-НА100А22Н155	100	22	48	155
ТН-НА100В27Н055	100	27	60	55
ТН-НА100В27Н155	100	27	60	155
ТН-НА100В32Н060	100	32	78	60
ТН-НА100В32Н155	100	32	78	155
ТН-НА100С40Н060	100	40	89	60
ТН-НА100С40Н155	100	40	89	155

Оправки HSK DIN 69893 для торцовых фрез с посадкой формы А с внутренней подачей СОЖ

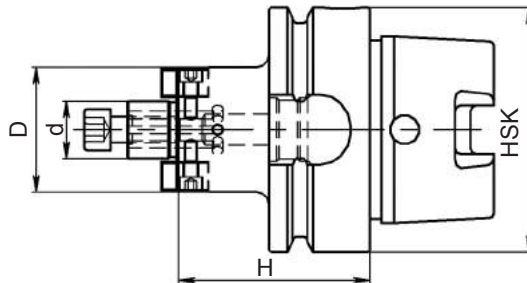
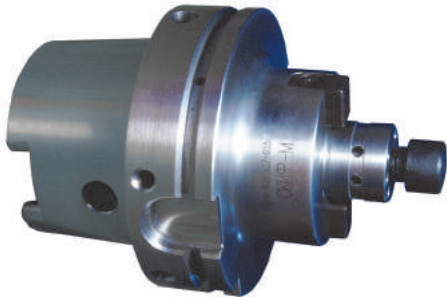

Обозначение	Размеры, мм			
	HSK	d	D	H
ТН-НАО63...А...Н...АD $n_{max}=8\ 000$ об/мин				
ТН-НАО63А16Н045АD	63	16	38	45
ТН-НАО63А16Н100АD	63	16	38	100
ТН-НАО63А16Н145АD	63	16	38	145
ТН-НАО63А22Н050АD	63	22	48	50
ТН-НАО63А22Н075АD	63	22	48	75
ТН-НАО63А22Н100АD	63	22	48	100
ТН-НАО63А22Н150АD	63	22	48	150
ТН-НАО63А27Н060АD	63	27	60	60
ТН-НАО63А27Н155АD	63	27	60	155
ТН-НАО63А32Н060АD	63	32	78	60
ТН-НАО63А32Н155АD	63	32	78	155
ТН-НАО63А40Н060АD	63	40	89	60
ТН-НАО63А40Н160АD	63	40	89	160
ТН-НАО100...А...Н...АD $n_{max}=8\ 000$ об/мин				
ТН-НАО100А16Н055АD	100	16	38	55
ТН-НАО100А16Н110АD	100	16	38	110
ТН-НАО100А16Н155АD	100	16	38	155
ТН-НАО100А22Н055АD	100	22	48	55
ТН-НАО100А22Н110АD	100	22	48	110
ТН-НАО100А22Н155АD	100	22	48	155
ТН-НАО100А27Н055АD	100	27	60	55
ТН-НАО100А27Н155АD	100	27	60	155
ТН-НАО100А32Н060АD	100	32	78	60
ТН-НАО100А32Н155АD	100	32	78	155
ТН-НАО100А40Н060АD	100	40	89	60
ТН-НАО100А40Н155АD	100	40	89	155
ТН-НАО125...А...Н...АD $n_{max}=8\ 000$ об/мин				
ТН-НАО125А27Н060АD	125	27	60	60
ТН-НАО125А27Н160АD	125	27	60	160
ТН-НАО125А32Н085АD	125	32	78	85
ТН-НАО125А32Н140АD	125	32	78	140
ТН-НАО125А32Н210АD	125	32	78	210
ТН-НАО125А40Н085АD	125	40	89	85
ТН-НАО125А40Н140АD	125	40	89	140
ТН-НАО125А40Н210АD	125	40	89	210

Оправки балансируемые HSK DIN 69893 для торцовых фрез с посадкой формы А с внутренней подачей СОЖ

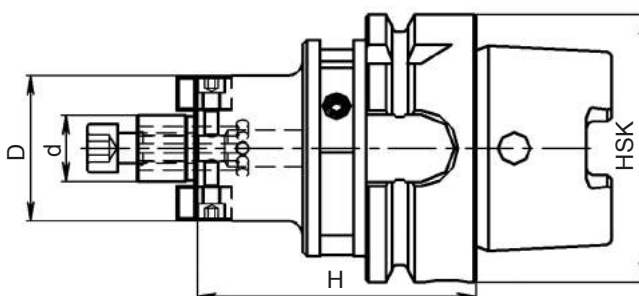

Обозначение	Размеры, мм			
	HSK	d	D	H
TH-HA063...A...H...ADG2.5	балансируемые $n_{max}=25\ 000$ об/мин G2.5			
TH-HA063A16H045ADG2.5	63	16	38	45
TH-HA063A16H145ADG2.5	63	16	38	145
TH-HA063A22H055ADG2.5	63	22	48	55
TH-HA063A22H150ADG2.5	63	22	48	150
TH-HA063A27H060ADG2.5	63	27	60	60
TH-HA063A27H155ADG2.5	63	27	60	155
TH-HA063A32H060ADG2.5	63	32	78	60
TH-HA063...A...H...ADG2.5	балансируемые $n_{max}=20\ 000$ об/мин G2.5			
TH-HA063A32H155ADG2.5	63	32	78	155
TH-HA063A40H060ADG2.5	63	40	89	60
TH-HA100...A...H...ADG2.5	балансируемые $n_{max}=20\ 000$ об/мин G2.5			
TH-HA100A16H055ADG2.5	100	16	38	55
TH-HA100A22H055ADG2.5	100	22	48	55
TH-HA100A27H055ADG2.5	100	27	60	55
TH-HA100A32H060ADG2.5	100	32	78	60
TH-HA100A40H060ADG2.5	100	40	89	60

Балансировочный элемент



HSK63 B510805
HSK100 B840805

Винт балансировки



H600500-30

Ключ балансировки



7003H

Втулки переходные HSK DIN 69893 для сверл с конусом Морзе с лапкой

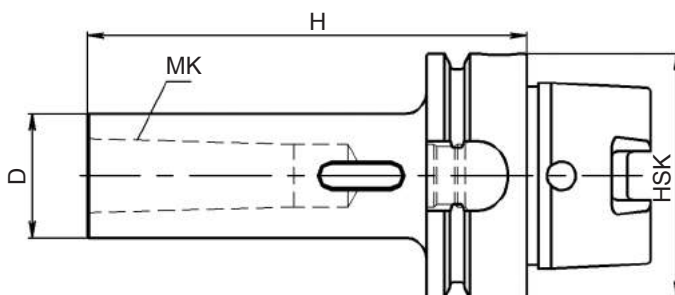

Обозначение	Размеры, мм			
	HSK	МК	D	H
TH-HA063...ML...H				
TH-HA063ML1H100	63	1	25	100
TH-HA063ML2H120	63	2	32	120
TH-HA063ML3H140	63	3	40	140
TH-HA063ML4H160	63	4	48	160
TH-HA100...ML...H				
TH-HA100ML2H120	100	2	32	120
TH-HA100ML3H150	100	3	40	150
TH-HA100ML4H170	100	4	48	170

Втулки переходные HSK DIN 69893 для фрез с конусом Морзе с резьбовым отверстием

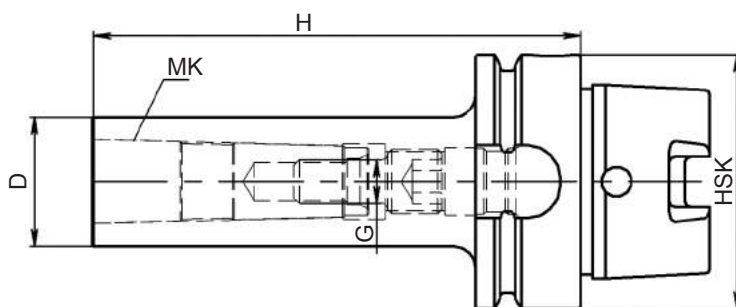

Обозначение	Размеры, мм				
	HSK	МК	D	H	G
TH-HA063...MG...H					
TH-HA063MG1H100	63	1	25	100	M 6
TH-HA063MG2H120	63	2	32	120	M 10
TH-HA063MG3H140	63	3	40	140	M 12
TH-HA063MG4H160	63	4	48	160	M 16
TH-HA100...MG...H					
TH-HA100MG2H120	100	2	32	120	M 10
TH-HA100MG3H150	100	3	40	150	M 12
TH-HA100MG4H170	100	4	48	170	M 16

Втулки переходные с DIN 69893 на DIN 26623-1

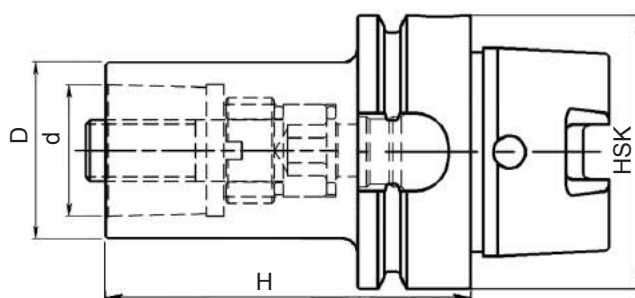

Обозначение	Размеры, мм			
	HSK	d	D	H
TH-NA063C...H				
TH-NA063C06H110	63	C06	63	110
TH-NA100C...H				
TH-NA100C06H090	100	C06	63	90
TH-NA100C06H150	100	C06	63	150

Патроны сверлильные высокоточные HSK DIN 69893

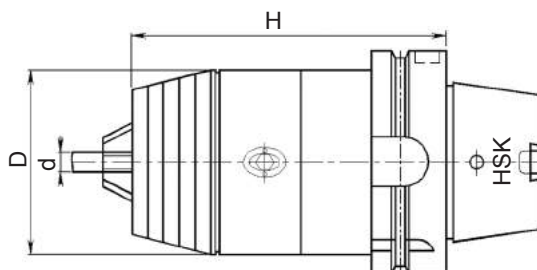

Обозначение	Размеры, мм			
	HSK	d	D	H
TH-NA063...D...H				
TH-NA063D13H104	63	1-13	50	104
TH-NA063D16H109	63	2,5-16	57	109
TH-NA063D13H104AD	63	1-13	50	104
TH-NA063D16H109AD	63	2,5-16	57	109
TH-NA100...D...H				
TH-NA100D13H111	100	1-13	50	111
TH-NA100D16H116	100	2,5-16	57	116
TH-NA100D13H111AD	100	1-13	50	111
TH-NA100D16H116AD	100	2,5-16	57	116

Патроны цанговые балансируемые HSK DIN 69893 системы OZ

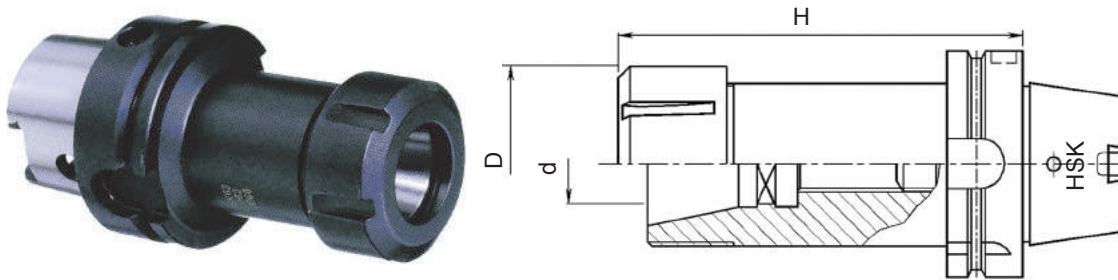

Обозначение	HSK	Размеры, мм			Цанга
		d	D	H	
TH-NA063...Z...H...G2.5					$n_{max} = 20000$ об/мин
TH-NA063Z16H080G2.5	63	2-16	43	80	OZ 16
TH-NA063Z25H080G2.5	63	2-25	60	80	OZ 25
TH-NA063Z25H130G2.5	63	2-25	60	130	OZ 25
TH-NA063Z32H100G2.5	63	3-32	72	100	OZ 32
TH-NA100...Z...H...G2.5					
TH-NA100Z25H100G2.5	100	2-25	60	100	OZ 25
TH-NA100Z32H105G2.5	100	3-32	72	105	OZ 32

Выбор цанги
стр. 500

Патроны резьбонарезные HSK DIN 69893

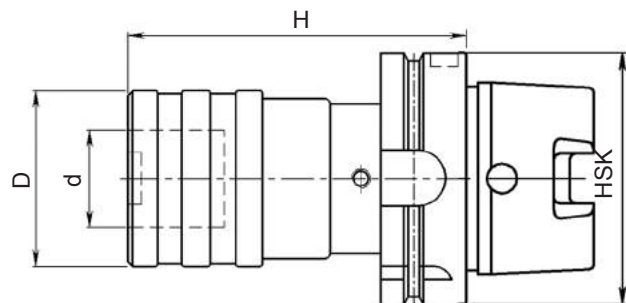

Обозначение	HSK	Размеры, мм			Размер	Резьба
		d	D	H		
TH-NA063...M-M						
TH-NA063M3-M12	63	19	38	102	1	M3-M12
TH-NA063M8-M20	63	31	54	152	2	M8-M20
TH-NA100...M-M						
TH-NA100M3-M12	100	19	38	112	1	M3-M12
TH-NA100M8-M20	100	31	54	100	2	M8-M20
TH-NA100M14-M32	100	48	86	144	3	M14-M32

Вставки
резьбонарезные стр. 501

Балансировочный элемент



HSK63 B510805
HSK100 B840805

Винт балансировки



H600500-30

Ключ балансировки



7003H

Термопатроны HSK DIN 69893

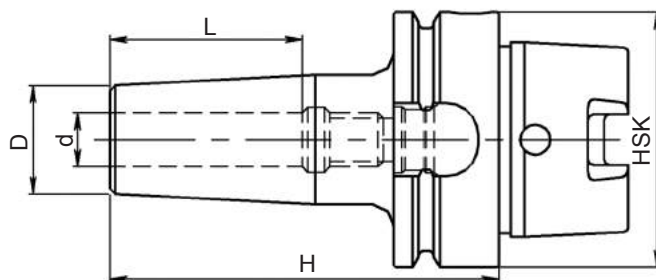
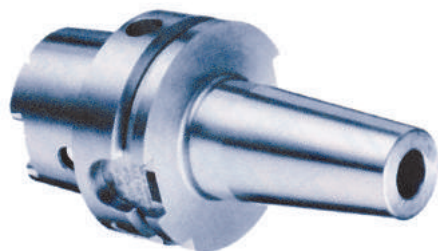

Обозначение	Размеры, мм				
	HSK	d	D	L	H
ТН-НА063...Т...Н <i>нормальное исполнение</i>					
ТН-НА063Т06Н080	63	6	20	36	80
ТН-НА063Т08Н080	63	8	20	36	80
ТН-НА063Т10Н085	63	10	24	42	85
ТН-НА063Т12Н090	63	12	24	47	90
ТН-НА063Т14Н090	63	14	27	47	90
ТН-НА063Т16Н090	63	16	27	50	90
ТН-НА063Т18Н095	63	18	33	50	95
ТН-НА063Т20Н100	63	20	33	52	100
ТН-НА063Т25Н115	63	25	44	58	115
ТН-НА063Т32Н120	63	32	44	58	120

Обозначение	Размеры, мм				
	HSK	d	D	L	H
ТН-НА063...Т...Н <i>длинное исполнение</i>					
ТН-НА063Т06Н160	63	6	20	36	160
ТН-НА063Т08Н160	63	8	20	36	160
ТН-НА063Т10Н160	63	10	24	42	160
ТН-НА063Т12Н160	63	12	24	47	160
ТН-НА063Т14Н160	63	14	27	47	160
ТН-НА063Т16Н160	63	16	27	50	160
ТН-НА063Т18Н160	63	18	33	50	160
ТН-НА063Т20Н160	63	20	33	52	160
ТН-НА063Т25Н160	63	25	44	58	160
ТН-НА063Т32Н160	63	32	44	58	160

Обозначение	Размеры, мм				
	HSK	d	D	L	H
ТН-НА100...Т...Н <i>нормальное исполнение</i>					
ТН-НА100Т06Н085	100	6	20	36	85
ТН-НА100Т08Н085	100	8	20	36	85
ТН-НА100Т10Н090	100	10	24	42	90
ТН-НА100Т12Н095	100	12	24	47	95
ТН-НА100Т14Н095	100	14	27	47	95
ТН-НА100Т16Н100	100	16	27	50	100
ТН-НА100Т18Н100	100	18	33	50	100
ТН-НА100Т20Н105	100	20	33	52	105
ТН-НА100Т25Н115	100	25	44	58	115
ТН-НА100Т32Н120	100	32	44	58	120

Обозначение	Размеры, мм				
	HSK	d	D	L	H
ТН-НА100...Т...Н <i>длинное исполнение</i>					
ТН-НА100Т06Н160	100	6	20	36	160
ТН-НА100Т08Н160	100	8	20	36	160
ТН-НА100Т10Н160	100	10	24	42	160
ТН-НА100Т12Н160	100	12	24	47	160
ТН-НА100Т14Н160	100	14	27	47	160
ТН-НА100Т16Н160	100	16	27	50	160
ТН-НА100Т18Н160	100	18	33	50	160
ТН-НА100Т20Н160	100	20	33	52	160
ТН-НА100Т25Н160	100	25	44	58	160
ТН-НА100Т32Н160	100	32	44	58	160

Термопатроны HSK DIN 69893

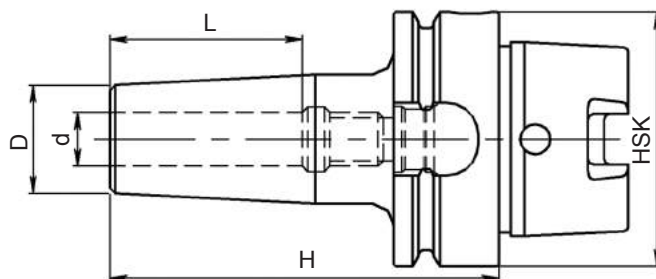
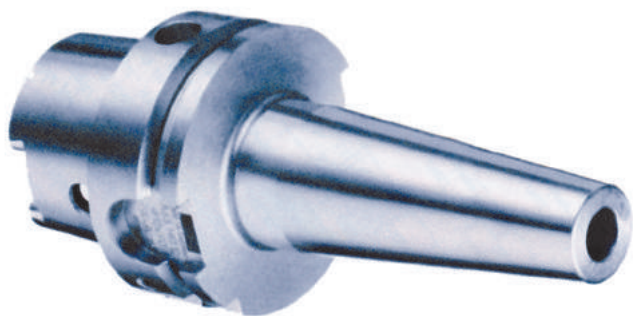

Обозначение	Размеры, мм				
	HSK	d	D	L	H
ТН-НА125...Т...Н...АD					<i>нормальное исполнение</i>
ТН-НА125Т10Н130АD	125	10	24	42	130
ТН-НА125Т10Н160АD	125	10	24	42	160
ТН-НА125Т10Н200АD	125	10	24	42	200
ТН-НА125Т12Н130АD	125	12	24	47	130
ТН-НА125Т12Н160АD	125	12	24	47	160
ТН-НА125Т12Н200АD	125	12	24	47	200
ТН-НА125Т14Н130АD	125	14	27	47	130
ТН-НА125Т14Н160АD	125	14	27	47	160
ТН-НА125Т14Н200АD	125	14	27	47	200
ТН-НА125Т16Н100АD	125	16	27	50	100
ТН-НА125Т16Н130АD	125	16	27	50	130
ТН-НА125Т16Н160АD	125	16	27	50	160
ТН-НА125Т16Н200АD	125	16	27	50	200
ТН-НА125Т18Н100АD	125	18	33	50	100
ТН-НА125Т18Н130АD	125	18	33	50	130
ТН-НА125Т18Н160АD	125	18	33	50	160
ТН-НА125Т18Н200АD	125	18	33	50	200
ТН-НА125Т20Н105АD	125	20	44	52	105
ТН-НА125Т20Н130АD	125	20	44	52	130
ТН-НА125Т20Н160АD	125	20	44	52	160
ТН-НА125Т20Н200АD	125	20	44	52	200
ТН-НА125Т25Н115АD	125	25	44	58	115
ТН-НА125Т25Н160АD	125	25	44	58	160
ТН-НА125Т25Н200АD	125	25	44	58	200
ТН-НА125Т32Н120АD	125	32	44	58	120
ТН-НА125Т32Н160АD	125	32	44	58	160
ТН-НА125Т32Н200АD	125	32	44	58	200

Вспомогательный инструмент СКИФ-М с полигональным хвостовиком DIN 26623-1

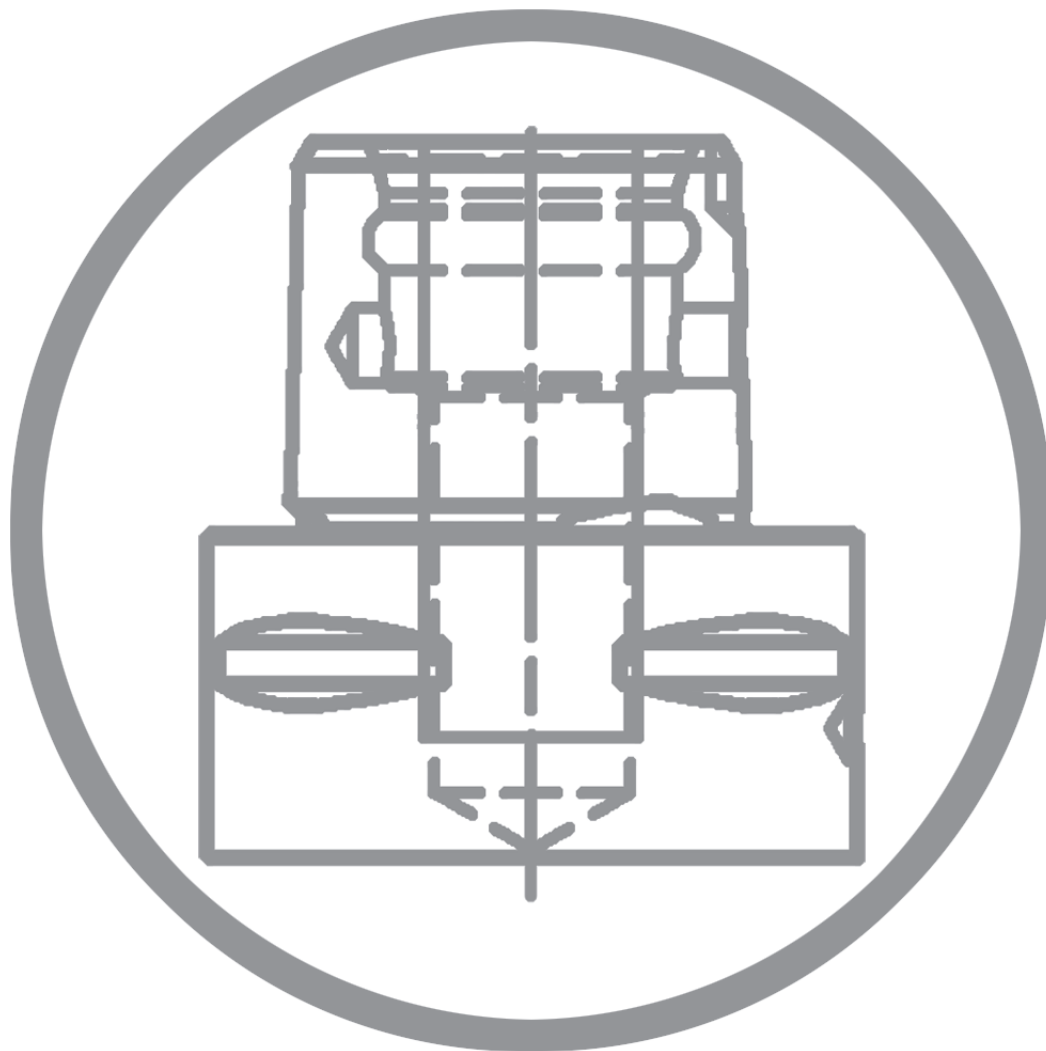

		Стр.
TH-C0...W...H	Оправки с полигональным хвостовиком DIN 26623-1 для концевых фрез с хвостовиком типа Weldon	494
TH-C0...A...H	Оправки с полигональным хвостовиком DIN 26623-1 для торцовых фрез с посадкой формы А	495
TH-C0...M-M	Патроны резьбонарезные PSK DIN 26623-1	496
TH-C04C04H	Удлинитель с полигональным хвостовиком DIN 26623-1	497
TH-C05C...H	Втулки переходные с DIN 26623-1 на DIN 26623-1 меньшего размера	497
TH-Z...T...L	Термоудлинители	498

Оправки с полигональным хвостовиком DIN 26623-1 для концевых фрез с хвостовиком типа Weldon

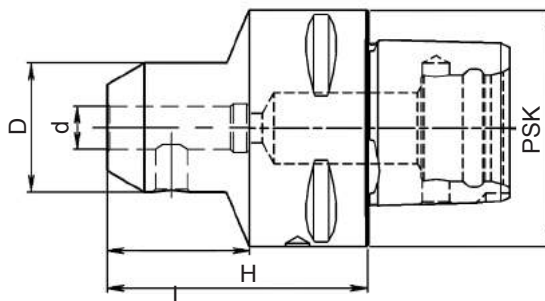

Обозначение	Размеры, мм				
	PSK	d	D	L	H
TH-C04...W...H					
TH-C04W06H050	40	6	25	25	50
TH-C04W08H050	40	8	28	26	50
TH-C04W10H051	40	10	35	29	51
TH-C04W12H055	40	12	42	-	55
TH-C04W16H055	40	16	48	-	55
TH-C05...W...H					
TH-C05W06H050	50	6	25	26	50
TH-C05W08H050	50	8	28	26	50
TH-C05W10H055	50	10	35	28	55
TH-C05W12H060	50	12	42	36	60
TH-C05W16H060	50	16	48	40	60
TH-C05W20H060	50	20	52	-	60
TH-C05W25H080	50	25	64	-	80
TH-C06...W...H					
TH-C06W06H055	63	6	25	25	55
TH-C06W08H055	63	8	28	26	55
TH-C06W10H060	63	10	35	30	60
TH-C06W12H060	63	12	42	33	60
TH-C06W14H060	63	14	44	34	60
TH-C06W16H065	63	16	48	34	65
TH-C06W20H065	63	20	52	38	65
TH-C06W25H080	63	25	63	-	80
TH-C06W32H090	63	32	72	-	90
TH-C08...W...H					
TH-C08W06H070	80	6	25	27	70
TH-C08W08H070	80	8	28	28	70
TH-C08W10H070	80	10	35	29	70
TH-C08W12H070	80	12	42	31	70
TH-C08W16H070	80	16	48	32	70
TH-C08W20H070	80	20	52	35	70
TH-C08W25H080	80	25	64	50	80
TH-C08W32H080	80	32	72	50	80
TH-C08W40H110	80	40	80	-	110

**Винт
крепления "Weldon"**

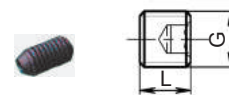

d, мм	G, мм	L, мм
6	M 6	10
8	M 8	10
10	M 10	12
12	M 12	16
14	M 12	16
16	M 14	16
18	M 14	16
20	M 16	16
22	M 16	16
25	M 18x2	20
32	M 20x2	20
40	M 20x2	25
50	M 24x2	25

Оправки с полигональным хвостовиком DIN 26623-1 для торцовых фрез с посадкой формы А

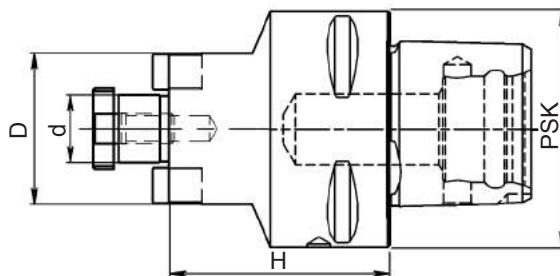

Обозначение	Размеры, мм			
	PSK	d	D	H
TH-C04...A...H				
TH-C04A16H032	40	16	32	32
TH-C04A22H025	40	16	32	25
TH-C05...A...H				
TH-C05A16H035	50	16	32	35
TH-C05A22H025	50	22	50	25
TH-C05A27H025	50	27	56	25
TH-C05A32H040	50	32	63	40
TH-C06...A...H				
TH-C06A16H040	63	16	32	40
TH-C06A22H025	63	22	55	25
TH-C06A27H025	63	27	63	25
TH-C06A32H025	63	32	63	25
TH-C08...A...H				
TH-C08A16H040	80	16	32	40
TH-C08A22H025	80	22	55	25
TH-C08A27H025	80	27	65	25
TH-C08A32H025	80	32	80	25
TH-C08A40H030	80	40	80	30

Патроны резьбонарезные PSK DIN 26623-1

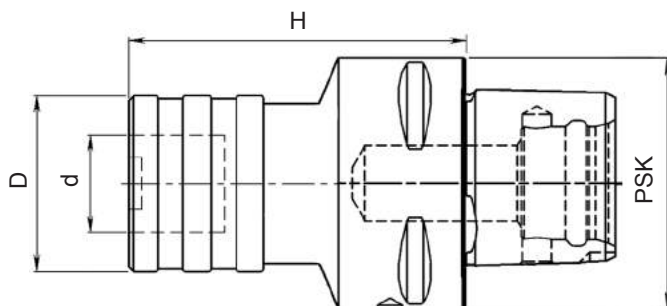

Обозначение	Размеры, мм			Размер	Резьба
	PSK	d	D		
TH-C04...M-M					
TH-C04M3-M12	40	19	38	1	M3-M12
TH-C04M8-M20	40	31	54	2	M8-M20
TH-C05...M-M					
TH-C05M3-M12	50	19	38	1	M3-M12
TH-C05M8-M20	50	31	54	2	M8-M20
TH-C06...M-M					
TH-C06M3-M12	63	19	41	1	M3-M12
TH-C06M8-M20	63	31	60	2	M8-M20
TH-C06M14-M33	63	48	86	3	M14-M33
TH-C08...M-M					
TH-C08M3-M12	80	19	41	1	M3-M12
TH-C08M8-M20	80	31	60	2	M8-M20
TH-C08M14-M33	80	48	86	3	M14-M33

Вставки
резьбонарезные стр. 501

Удлинитель с полигональным хвостовиком DIN 26623-1

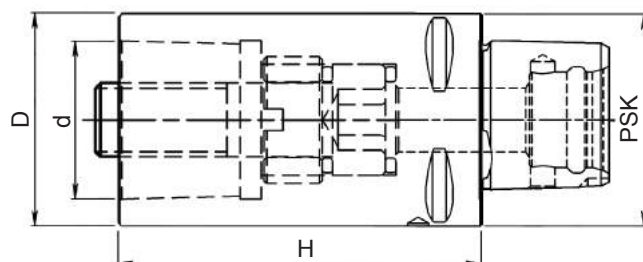

Обозначение	Размеры, мм			
	PSK	d	D	H
TH-C04C04H				
TH-C04C04H060	40	C04	40	60
TH-C04C04H080	40	C04	40	80
TH-C05C05H				
TH-C05C05H050	50	C05	50	50
TH-C05C05H080	50	C05	50	80
TH-C06C06H				
TH-C06C06H100	63	C06	63	100
TH-C06C06H125	63	C06	63	125
TH-C08C08H				
TH-C08C08H100	80	C08	80	100
TH-C08C08H140	80	C08	80	140

Втулки переходные с DIN 26623-1 на DIN 26623-1 меньшего размера

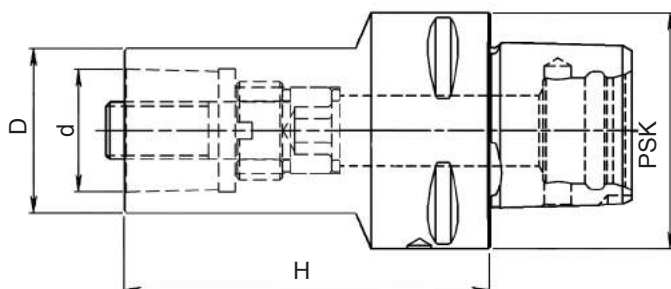

Обозначение	Размеры, мм			
	PSK	d	D	H
TH-C05C...H				
TH-C05C04H065	50	C04	40	65
TH-C06C...H				
TH-C06C04H080	63	C04	40	80
TH-C06C05H080	63	C05	50	80
TH-C08C...H				
TH-C08C05H120	80	C05	50	120
TH-C08C06H080	80	C06	63	80

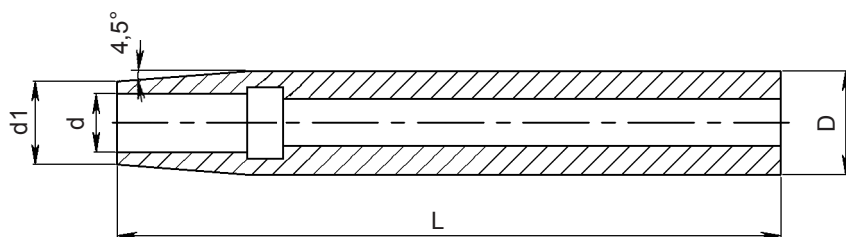
Термоудлинители

Обозначение	Размеры, мм			
	D	d	d1	L

ТН-З...Т...L

ТН-З16Т06L150	16	6	10	150
ТН-З20Т06L150	20	6	10	150
ТН-З20Т08L150	20	8	12	150
ТН-З20Т10L150	20	10	14	150
ТН-З20Т12L150	20	12	16	150
ТН-З25Т08L150	25	8	20	150
ТН-З25Т10L150	25	10	20	150
ТН-З25Т12L150	25	12	20	150
ТН-З25Т14L150	25	14	20	150
ТН-З25Т16L150	25	16	22	150
ТН-З32Т10L150	32	10	24	150
ТН-З32Т12L150	32	12	24	150
ТН-З32Т14L150	32	14	27	150
ТН-З32Т16L150	32	16	27	150
ТН-З32Т18L150	32	18	27	150
ТН-З32Т20L150	32	20	27	150

Запчасти для вспомогательного инструмента СКИФ-М



	Стр.
Цанги OZ DIN 6388B	500
Ключи для патрона цангового OZ	500
Быстросменные цанги для метчиков	501
Винты крепления торцовых фрез по ГОСТ11738-72 и DIN 6367	502
Ключи к оправкам для торцовых и насадных фрез DIN 6368	503
Кольцо-шпонка по DIN 6366	503
Центральные зажимные болты MAS BT	503
Центральные зажимные болты DIN 69872	503
Центральные зажимные болты DIN 2080	504
Центральные болты-переходники DIN 69872 - DIN 2080	504
Наконечники для подвода СОЖ HSK	504
Ключи наконечника HSK	504
Кольца проставочные для комбинированных оправок по DIN 2084 B	505

Цанги OZ DIN 6388B

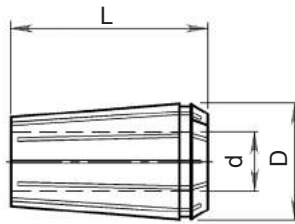

d, мм	Обозначение		
	OZ16 D=25,5 мм L=40 мм	OZ25 D=35,5 мм L=52 мм	OZ32 D=44 мм L=40 мм

OZ... DIN 6388B

2,0	OZ16x2	OZ25x2	OZ32x2
3,0	OZ16x3	OZ25x3	OZ32x3
4,0	OZ16x4	OZ25x4	OZ32x4
5,0	OZ16x5	OZ25x5	OZ32x5
6,0	OZ16x6	OZ25x6	OZ32x6
7,0	OZ16x7	OZ25x7	OZ32x7
8,0	OZ16x8	OZ25x8	OZ32x8
9,0	OZ16x9	OZ25x9	OZ32x9
10,0	OZ16x10	OZ25x10	OZ32x10
11,0	OZ16x11	OZ25x11	OZ32x11
12,0	OZ16x12	OZ25x12	OZ32x12
13,0	OZ16x13	OZ25x13	OZ32x13
14,0	OZ16x14	OZ25x14	OZ32x14
15,0	OZ16x15	OZ25x15	OZ32x15
16,0	OZ16x16	OZ25x16	OZ32x16
17,0		OZ25x17	OZ32x17
18,0		OZ25x18	OZ32x18
19,0		OZ25x19	OZ32x19
20,0		OZ25x20	OZ32x20
21,0		OZ25x21	OZ32x21
22,0		OZ25x22	OZ32x22
23,0		OZ25x23	OZ32x23
24,0		OZ25x24	OZ32x24
25,0		OZ25x25	OZ32x25
26,0			OZ32x26
27,0			OZ32x27
28,0			OZ32x28
29,0			OZ32x29
30,0			OZ32x30
31,0			OZ32x31
32,0			OZ32x32

Ключи для патрона цангового OZ



Тип цанги	OZ16	OZ25	OZ32
Обозначение	G17 - 16	G17 - 25	G17 - 32

Быстросменные цанги для метчиков

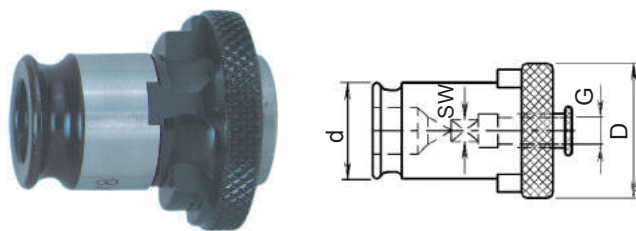
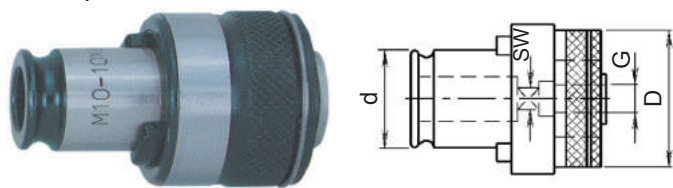

Обозначение	Размер	Размеры, мм			
		G	SW	d	D
G...d...X..		с предохранительной муфтой			
G028d19x1	1	2,8	2,1	19	32
G031d19x1	1	3,15	2,5	19	32
G035d19x1	1	3,5	2,7	19	32
G040d19x1	1	4	3	19	32
G041d19x1	1	4	3,2	19	32
G045d19x1	1	4,5	3,4	19	32
G050d19x1	1	5	4	19	32
G060d19x1	1	6	4,9	19	32
G061d19x1	1	6	4,9(M5)	19	32
G063d19x1	1	6,3	5	19	32
G070d19x1	1	7	5,5	19	32
G080d19x1	1	8	6,2	19	32
G090d19x1	1	9	7	19	32
G100d19x1	1	10	8	19	32
G110d19x1	1	11	9	19	32
G120d19x1	1	12	9	19	32
G060d31x2	2	6	4,9	31	50
G063d31x2	2	6,3	5	31	50
G070d31x2	2	7	5,5	31	50
G080d31x2	2	8	6,2	31	50
G090d31x2	2	9	7	31	50
G100d31x2	2	10	8	31	50
G110d31x2	2	11	9	31	50
G112d31x2	2	11,2	9	31	50
G120d31x2	2	12	9	31	50
G125d31x2	2	12,5	10	31	50
G140d31x2	2	14	11	31	50
G141d31x2	2	14	11,2	31	50
G160d31x2	2	16	12	31	50
G161d31x2	2	16	12,5	31	50
G180d31x2	2	18	14,5	31	50
G200d31x2	2	20	16	31	50
G090d48x3	3	9	7	48	72
G110d48x3	3	11	9	48	72
G120d48x3	3	12	9	48	72
G140d48x3	3	14	11	48	72
G160d48x3	3	16	12	48	72
G180d48x3	3	18	14,5	48	72
G200d48x3	3	20	16	48	72
G220d48x3	3	22	18	48	72
G250d48x3	3	25	20	48	72
G280d48x3	3	28	9	48	72

Обозначение	Размер	Размеры, мм			
		G	SW	d	D
GW...d...X..		без предохранительной муфты			
GW028d19x1	1	2,8	2,1	19	32
GW031d19x1	1	3,15	2,5	19	32
GW035d19x1	1	3,5	2,7	19	32
GW040d19x1	1	4	3	19	32
GW041d19x1	1	4	3,2	19	32
GW045d19x1	1	4,5	3,4	19	32
GW050d19x1	1	5	4	19	32
GW060d19x1	1	6	4,9	19	32
GW063d19x1	1	6,3	5	19	32
GW070d19x1	1	7	5,5	19	32
GW080d19x1	1	8	6,2	19	32
GW090d19x1	1	9	7	19	32
GW100d19x1	1	10	8	19	32
GW110d19x1	1	11	9	19	32
GW120d19x1	1	12	9	19	32
GW060d31x2	2	6	4,9	31	50
GW063d31x2	2	6,3	5	31	50
GW070d31x2	2	7	5,5	31	50
GW080d31x2	2	8	6,2	31	50
GW090d31x2	2	9	7	31	50
GW100d31x2	2	10	8	31	50
GW110d31x2	2	11	9	31	50
GW112d31x2	2	11,2	9	31	50
GW120d31x2	2	12	9	31	50
GW125d31x2	2	12,5	10	31	50
GW140d31x2	2	14	11	31	50
GW141d31x2	2	14	11,2	31	50
GW160d31x2	2	16	12	31	50
GW161d31x2	2	16	12,5	31	50
GW180d31x2	2	18	14,5	31	50
GW200d31x2	2	20	16	31	50
GW090d48x3	3	9	7	48	72
GW110d48x3	3	11	9	48	72
GW120d48x3	3	12	9	48	72
GW140d48x3	3	14	11	48	72
GW160d48x3	3	16	12	48	72
GW180d48x3	3	18	14,5	48	72
GW200d48x3	3	20	16	48	72
GW220d48x3	3	22	18	48	72
GW250d48x3	3	25	20	48	72
GW280d48x3	3	28	9	48	72

Винты крепления торцовых фрез по ГОСТ11738-72 и DIN 6367

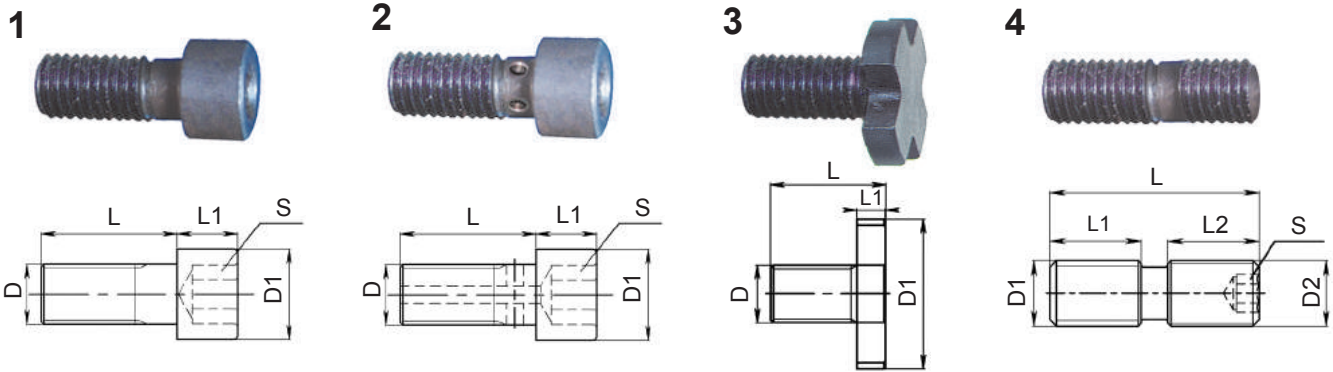

Обозначение	Тип винта	Форма крепления	Размеры, мм						
			d	D	D1	L	L1	S	Nm
H...00-...S ГОСТ11738-72			Для крепления торцовых и дисковых фрез						
H082800-06S	1	Форма А	16	M8	13	28	8	6	30
H102700-08S	1	Форма А	22	M10	16	27	10	8	50
H123000-10S	1	Форма А	27	M12	18	30	12	10	80
H163200-14S	1	Форма А	32	M16	24	32	16	14	110
H204500-17S	1	Форма А	40	M20	30	45	20	17	120

Для крепления торцовых фрез с формой крепления G

Обозначение	Тип винта	Форма крепления	Размеры, мм						
			D1	D2	L	L1	L2	S	Nm
H082200-40P	4	Форма G	M8	M8X0,75	22	7.5	10	4	15
H103200-50P	4	Форма G	M10	M10X0,75	32	14	14	5	20

Для крепления сменного торцового блока в торцово-цилиндрических фрезях

Обозначение	Тип винта	Форма крепления	Размеры, мм						
			d	D	D1	L	L1	S	Nm
H103500-08S	1	---	50	M10	13	35	10	8	50
H103600-08S	1	---	50	M10	13	36	10	8	50
H123600-10S	1	---	63	M12	16	36	12	10	80
H124000-10S	1	---	63	M12	16	40	12	10	80
H164500-14S	1	---	80	M16	18	45	16	14	110
H164500-14S	1	---	100	M16	18	45	16	14	110
H165000-14S	1	---	80	M16	18	50	16	14	110
H165000-14S	1	---	100	M16	18	50	16	14	110
H103500-08S-ИК	2	---	50	M10	13	35	10	8	50
H124000-10S-ИК	2	---	63	M12	16	40	12	10	80
H165000-14S-ИК	2	---	80	M16	18	50	16	14	110
H165000-14S-ИК	2	---	100	M16	18	50	16	14	110

GM...-... DIN 6367

Для крепления торцовых и дисковых фрез

Обозначение	Тип винта	Форма крепления	Размеры, мм						
			d	D	D1	L	L1	S	Nm
GM08-22	3	Форма S	16	M8	20	22	6	-	-
GM10-25	3	Форма S	22	M10	28	25	7	-	-
GM12-32	3	Форма B,S	27	M12	35	32	8	-	-
GM16-37	3	Форма B,S	32	M16	40	37	9	-	-
GM20-40	3	Форма B,C,S	40	M20	52	40	10	-	-
GM24-46	3	Форма S	50	M24	63	46	12	-	-
GM30-59	3	Форма S	60	M30	75	59	14	-	-

Ключи к оправкам для торцовых и насадных фрез DIN 6368

Обозначение	Размеры, мм		
	d*	L	H
TK...H... DIN 6368			
TK13H16	13	160	16
TK16H20	16	180	20
TK22H25	22	200	25
TK27H32	27	225	32
TK32H36	32	250	36
TK40H40	40	280	40
TK50H45	50	315	45
TK60H50	60	355	50

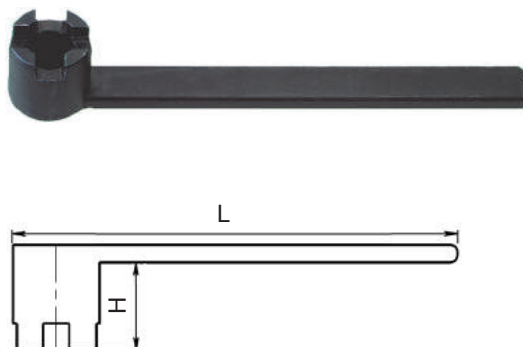

* d- посадочный размер торцевой фрезы

Кольцо-шпонка по DIN 6366

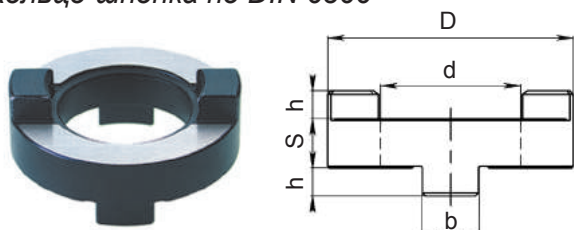

Обозначение	Размеры, мм				
	d	D	S	b	h
d...-D... DIN 6366					
d13-D28	13	28	10	8	5,0
d16-D32	16	32	10	8	5,0
d22-D40	22	40	12	10	5,6
d27-D48	27	48	12	12	6,3
d32-D58	32	58	14	14	7,0
d40-D70	40	70	14	16	8,0
d50-D90	50	90	16	18	9,0
d60-D110	60	110	16	20	10,0

Центральные зажимные болты MAS BT

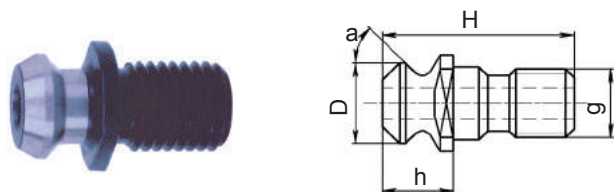

Обозначение	Размеры, мм					
	BT	D	h	H	g	a
G-BT40G...A... MAS BT 403						
G-BT40G16A45	40	15	35	60	M 16	45°
G-BT40G16A60	40	15	35	60	M 16	60°
G-BT40G16A90	40	15	35	60	M 16	90°
G-BT50G...A... MAS BT 403						
G-BT50G24A45	50	23	45	85	M 24	45°
G-BT50G24A60	50	23	45	85	M 24	60°
G-BT50G24A90	50	23	45	85	M 24	90°

Центральные зажимные болты DIN 69872

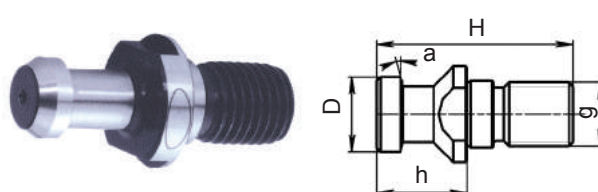

Обозначение	Размеры, мм					
	NC	D	h	H	g	a
G-NC40G... DIN 69872						
G-NC40G16AD	40	19	26	54	M 16	15°
G-NC40G16	40	19	26	54	M 16	15°
G-NC50G... DIN 69872						
G-NC50G24AD	50	28	34	74	M 24	15°
G-NC50G24	50	28	34	74	M 24	15°

Центральные зажимные болты DIN 2080

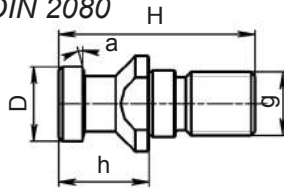

Обозначение	Размеры, мм					
	SK	D	h	H	g	a
G-SK40G... DIN 2080						
G-SK40G16	40	25	25	53	M 16	15°
G-SK50G... DIN 2080						
G-SK50G24	50	39,6	25,1	65,1	M 24	15°

Центральные болты-переходники DIN 69872 - DIN 2080

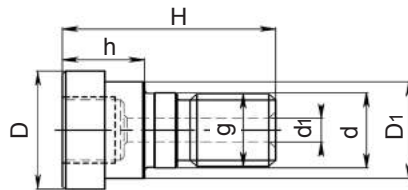

Обозначение	Размеры, мм							
	SK	D	D1	d	d1	H	h	g
H...X...-... DIN 69872 - DIN 2080								
H16x16-5322	40	25	22	17	7,5	53	25	M 16
H24x24-6532	50	39,5	32	25	11,5	65,1	25,1	M 24

Наконечники для подвода СОЖ HSK

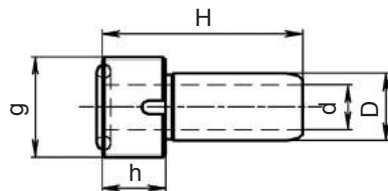

Обозначение	Размеры, мм					
	HSK	D	h	H	d	g
KMS.HSK...A DIN 69893						
KMS.HSK063A	63	12	11,3	36,2	8	M 18x1
KMS.HSK100A	100	16	15,5	44	12	M 24x1,5
KMS.HSK125A	125	18	17,5	48,5	14	M 30x1,5

Ключи наконечника HSK

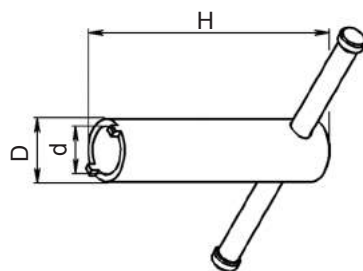

Обозначение	Размеры, мм			
	HSK	D	d	H
D...d...h... DIN 69893				
D17d13H070	63	17	13	70
D22d17H090	100	22	17	90
D28d19H150	125	28	19	150

Кольца проставочные для комбинированных оправок по DIN 2084 B

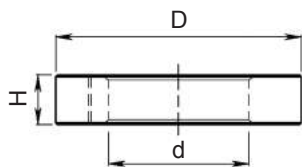

Обозначение	Размеры, мм		
	d	D	H
D27d16H... DIN 2084 B			
D27d16H02	16	27	2,0
D27d16H03	16	27	3,0
D27d16H04	16	27	4,0
D27d16H05	16	27	5,0
D27d16H06	16	27	6,0
D27d16H10	16	27	10,0
D27d16H20	16	27	20,0
D27d16H30	16	27	30,0

Обозначение	Размеры, мм		
	d	D	H
D34d22H... DIN 2084 B			
D34d22H02	22	34	2,0
D34d22H03	22	34	3,0
D34d22H04	22	34	4,0
D34d22H05	22	34	5,0
D34d22H06	22	34	6,0
D34d22H10	22	34	10,0
D34d22H20	22	34	20,0
D34d22H30	22	34	30,0
D34d22H60	22	34	60,0
D34d22H100	22	34	100,0

Обозначение	Размеры, мм		
	d	D	H
D41d27H... DIN 2084 B			
D41d27H02	27	41	2,0
D41d27H03	27	41	3,0
D41d27H04	27	41	4,0
D41d27H05	27	41	5,0
D41d27H06	27	41	6,0
D41d27H10	27	41	10,0
D41d27H20	27	41	20,0
D41d27H30	27	41	30,0
D41d27H60	27	41	60,0
D41d27H100	27	41	100,0

Обозначение	Размеры, мм		
	d	D	H
D47d32H... DIN 2084 B			
D47d32H02	32	47	2,0
D47d32H03	32	47	3,0
D47d32H04	32	47	4,0
D47d32H05	32	47	5,0
D47d32H06	32	47	6,0
D47d32H10	32	47	10,0
D47d32H20	32	47	20,0
D47d32H30	32	47	30,0
D47d32H60	32	47	60,0
D47d32H100	32	47	100,0

Обозначение	Размеры, мм		
	d	D	H
D55d40H... DIN 2084 B			
D55d40H02	40	55	2,0
D55d40H03	40	55	3,0
D55d40H04	40	55	4,0
D55d40H05	40	55	5,0
D55d40H06	40	55	6,0
D55d40H10	40	55	10,0
D55d40H20	40	55	20,0
D55d40H30	40	55	30,0
D55d40H60	40	55	60,0
D55d40H100	40	55	100,0

Обозначение	Размеры, мм		
	d	D	H
D69d50H... DIN 2084 B			
D69d50H02	50	69	2,0
D69d50H03	50	69	3,0
D69d50H04	50	69	4,0
D69d50H05	50	69	5,0
D69d50H06	50	69	6,0
D69d50H10	50	69	10,0
D69d50H20	50	69	20,0
D69d50H30	50	69	30,0
D69d50H60	50	69	60,0
D69d50H100	50	69	100,0