

## FIXING BRACKETS AND SUPPORTS

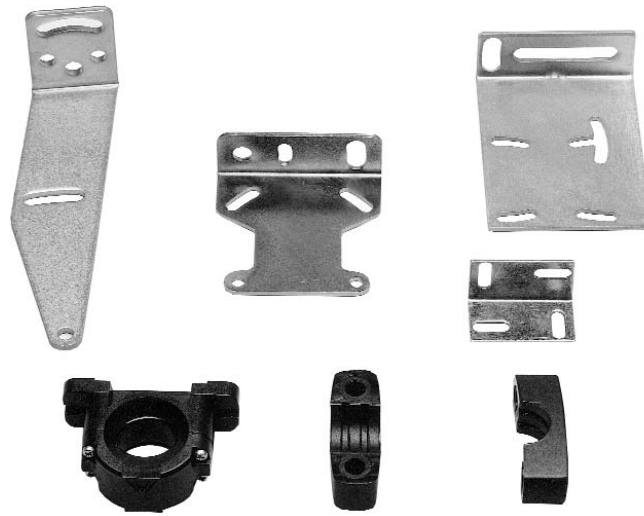

- *Fixing brackets for universal sensors*
- *Fixed supports for tubular M18 sensors*
- *Supports with optic axis regulation*
- *Good shock and vibration resistance*

## ST SERIES

The **ST** series includes all the fixing brackets and supports available for the fixing of photoelectric sensors.

The 'L' shaped fixing brackets are in metal and present dimensions that guarantee the best sensor fixing, offering the maximum resistance against shocks and vibrations that can alter the positioning.

The holes are multiple or slotted in order to offer the best fixing versatility, even in place of other sensors.

Plastic supports are available for tubular sensors: a fixed and an adjustable support with which the inclination of the sensor's optic axis can be regulated right up to a 15° angle in every direction for a 360° arch.



## DIMENSIONS

### ST-130

S30 fixing bracket  
material: yellow zinc-plated steel

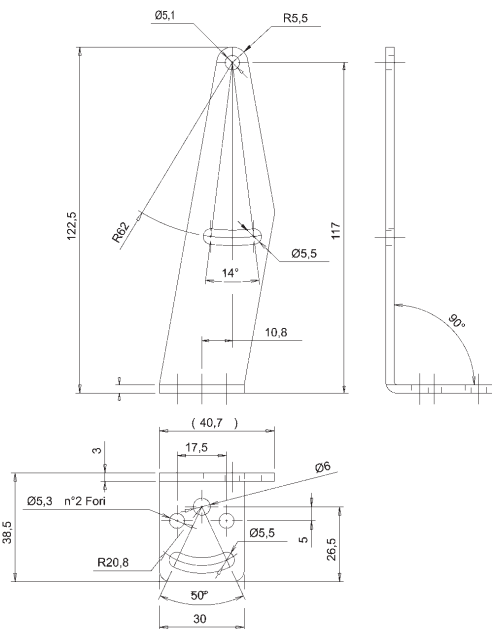

### ST-138

S30 fixing bracket (RT7 compatible)  
material: white zinc-plated steel

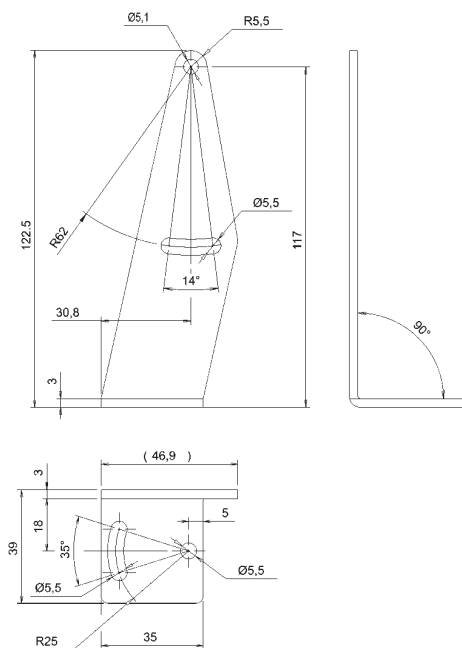

### ST-164

S20 fixing bracket  
material: yellow zinc-plated steel

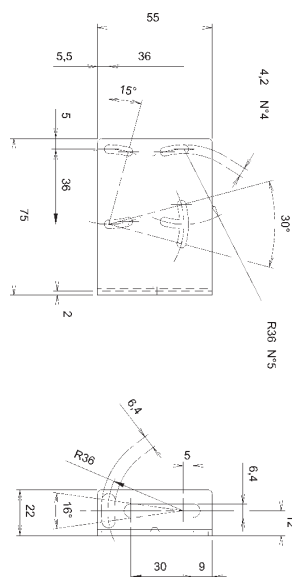

mm



**DIMENSIONS**

**ST-504**

S6 fixing brackets  
material: yellow zinc-plated steel

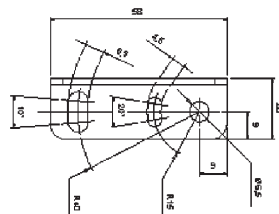
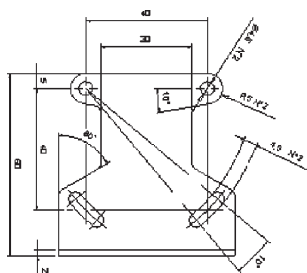

**ST-505**

S3/S40/S41 fixing bracket  
material: yellow zinc-plated steel

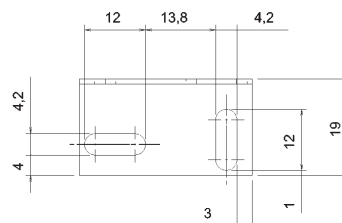
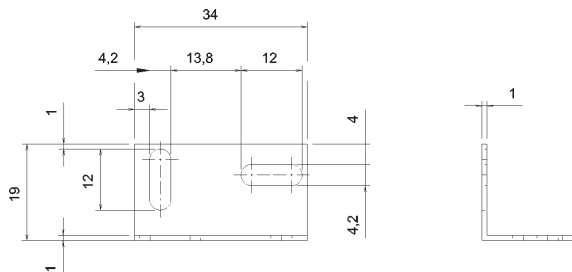

**SWING-18**

adjustable support for plastic tubular M18 sensors  
material: black dilamid

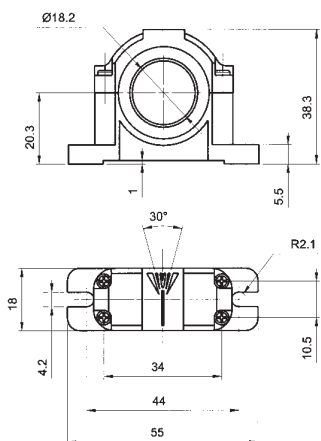

**SP-40**

fixed support for tubular M18 sensors  
material: black durethan

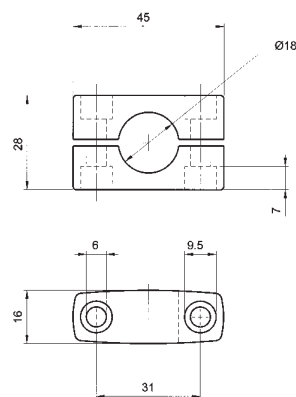



## MODEL SELECTION AND ORDER INFORMATION

MODEL	DESCRIPTION	CODE N°
ST-505	1 pc fixing bracket for S3/S40/S41	95ACC1300
ST-504	1 pc fixing bracket for S6	95ACC1320
ST-164	1 pc fixing bracket for S20	95ACC1340
ST-130	1 pc fixing bracket for S30	95ACC1350
ST-138	1 pc fixing bracket for S30 (RT7 compatible)	95ACC1360
SP-40	2 pcs fixed support for tubular M18 sensors	95ACC1370
SWING-18	1 pc adjustable support for plastic tubular M18 sensors	895000006

*Note: the fixing bracket for the S2/S3/S6 series is supplied with the sensor*

**Distributed by:**

### HEADQUARTERS

#### DATASENSOR SpA

via Lavino, 265 - 40050 Monte San Pietro, BO - Italy

Tel. +39 051/6765611 • Fax +39 051/6759324

[www.datasensor.com](http://www.datasensor.com) • e-mail [info@datasensor.com](mailto:info@datasensor.com)

Datasensor SpA endeavours to continuously improve and renew its products; for this reason the technical data and contents of this catalogue may undergo variations without prior notice. For correct installation and use Datasensor SpA can guarantee only the data indicated in the instruction manual supplied with the products.