

Laser sensors



PicoDot™ series
laser sensor for harsh environments

Wave length

Red
650 nm (convergent)
670 nm (retro-reflective)

Laser protection class
(EN 60825, IEC 60825)
Spot size at focal point

II
0,25 mm (at 50 mm – C50,
102 mm – C100 or 203 mm –
C200) (PD49V.6C... only)
sensitivity

Adjustment

Supply

Supply voltage 10...30 V dc
Ripple V_{pp} $\leq 10\%$
No load current ≤ 20 mA
Delay upon power up < 1 s

Protection

reverse polarity
short-circuit (pulsed)
transient voltages

Output

Complementary light and dark operate
Continuous load current ≤ 150 mA
Overload trip point ≥ 220 mA typical at 20 °C
Switching frequency 2,5 kHz

Material

Housing ABS
Lens acrylic
Protection class IP67
(IEC 60529/EN 60529)
Temperature range -10...+45 °C
Cable 2 m, PVC, 5 x 0,34 mm²
Connector eurocon (M12 x 1)

Indicator LED's

Yellow light sensed
Green power-on
Yellow flashing signal strength
Green flashing short-circuit or output overload

Accessories

Brackets

SMB46L	30 487 47	protective bracket
SMB46S	30 487 48	protective bracket
SMB46U	30 487 46	protective bracket
SMB46A	30 525 18	precision adjustment bracket
SMB46DF	30 487 40	bracket for 2 sensors

Connectors

WAK4.5-2/P00	80 085 76	straight type
WWAK4.5-2/P00	80 085 83	right-angled type

Reflector

BRT-36X40BM	30 498 11	included with retro models
-------------	-----------	----------------------------

Dimensions [mm]

● **Cable**

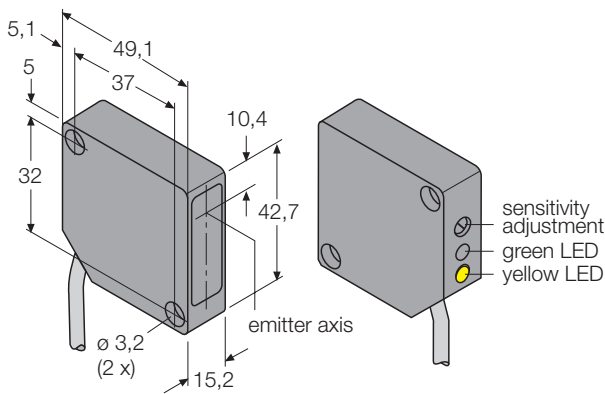

● **Connector**

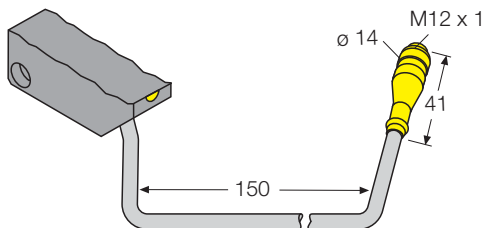

Wiring

pnp complementary

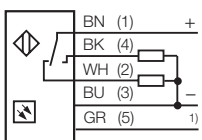

nPN complementary

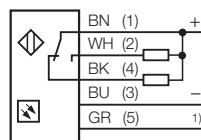

¹ laser control (+ OFF, - ON)

PicoDot™ series laser sensor for harsh environments

Excess gain curve:
Excess gain in relation to the distance

— Retro-reflective

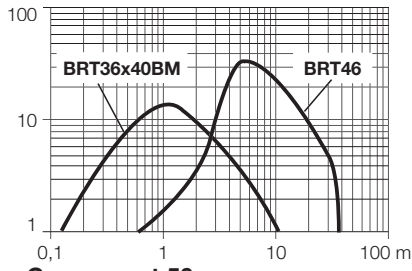

— Convergent 50 mm

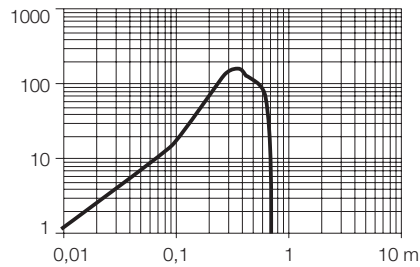

— Convergent 100 mm

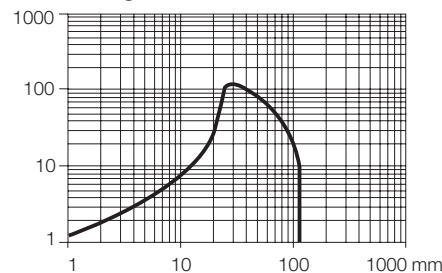

— Convergent 200 mm

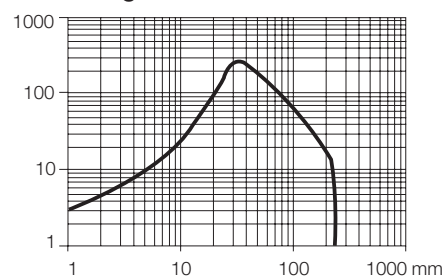

	<i>Max. range</i>	<i>Light source</i>	<i>Output function</i>	<i>Connection</i>	<i>Type</i>	<i>Ident number</i>
	10 m	red	pnp	cable	polarised with BRT-36x40BM	30 670 00
	10 m	red	pnp	connector	PD49VP6LLP	30 670 01
	10 m	red	nnp	cable	PD49VP6LLPQ	30 669 98
	10 m	red	nnp	connector	PD49VN6LLP	30 669 99
	39 m	red	pnp	cable	polarised with BRT46	30 670 00
	39 m	red	pnp	connector	PD49VP6LLP	30 670 01
	39 m	red	nnp	cable	PD49VP6LLPQ	30 669 98
	39 m	red	nnp	connector	PD49VN6LLP	30 669 99
	58 mm	red	pnp	cable	PD49VP6C50	30 669 88
	58 mm	red	pnp	connector	PD49VP6C50Q	30 669 89
	58 mm	red	nnp	cable	PD49VN6C50	30 669 86
	58 mm	red	nnp	connector	PD49VN6C50Q	30 669 87
	115 mm	red	pnp	cable	PD49VP6C100	30 669 92
	115 mm	red	pnp	connector	PD49VP6C100Q	30 669 93
	115 mm	red	nnp	cable	PD49VN6C100	30 669 90
	115 mm	red	nnp	connector	PD49VN6C100Q	30 669 91
	216 mm	red	pnp	cable	PD49VP6C200	30 669 96
	216 mm	red	pnp	connector	PD49VP6C200Q	30 669 97
	216 mm	red	nnp	cable	PD49VN6C200	30 669 94
	216 mm	red	nnp	connector	PD49VN6C200Q	30 669 95

Subject to changes without notice • Edition 02.02 • P/N ED092 – excerpt from EC001/0102



These sensors do not include the self-checking redundant circuitry necessary to allow their use in personnel safety applications. A sensor failure or malfunction can result in either an energised or de-energised output condition. These products should not be used as sensing devices for personnel safety.