

INTELLIGENTI SENSORS FOR ARTIFICIAL VISION



SMART CAMERA SENSORS



SCS1 Open Platform is the SCS1 version destined to vision system specialists and software developers.

The DATASENSOR Smart Camera offers a high-performance engineered hardware, which can be exploited by experts in programming and image processing in order to develop custom solutions in a rather short implementation time.

SCS1 Open Platform is infact an ideal kit for the rapid development of embedded devices, deriving from the combination of an application specific software with a flexible hardware as the one offered by DATASENSOR.

SCS1 Open Platform is available in two versions: 'Development Kit' offers the Smart Camera and software development tools and 'Open Platform' characterised by only hardware. All the software tools, vision algorithms and the GUI currently offered by the standard SCS1 are not included in the Open Platform models. Open Platform models are without integrated illuminator and do not include any objective.

SCS1 COMPACT SMART CAMERA SENSORS

(495) 221-58-89 <http://www.newic.ru> <http://www.insensor.ru>

In a completely integrated housing, the **SCS1** offers all the principal functions of a complex vision system:

image acquisition: grey-scale CMOS 640x480 sensor

optics: interchangeable optics with C or CS mounting (not included)

illumination: integrated or external
connectivity: digital I/O, Ethernet communication, serial interface



Interchangeable optics (not included)



DIMENSIONS

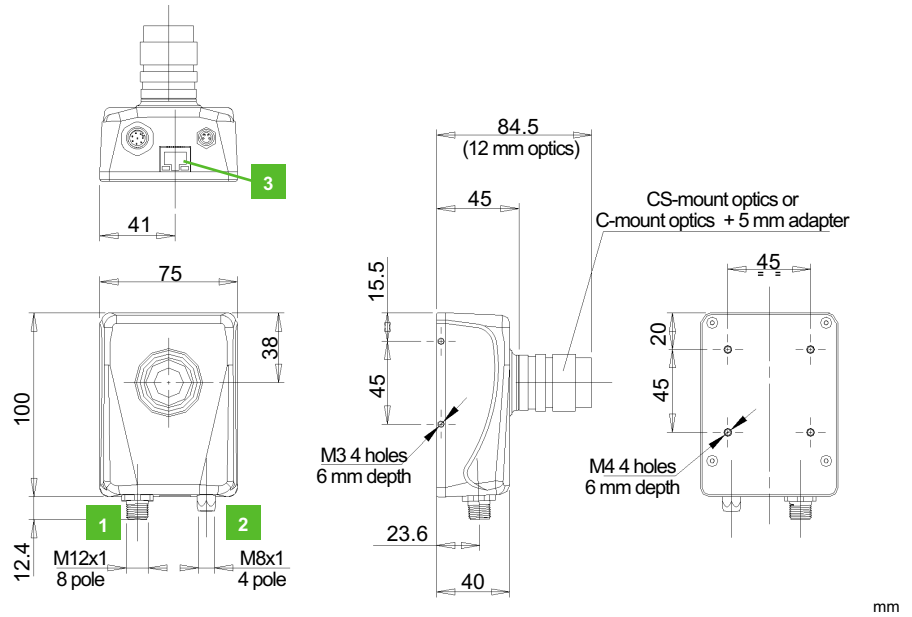

CONNECTOR LAYOUT

- 1 M12 8-pole I/O connector
- 2 M8 4-pole lighting connector
- 3 RJ45 Ethernet connector

INDICATORS AND SETTINGS

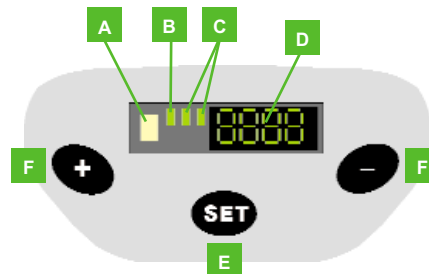

- A Output 1 status LED
- B Output 2 status LED
- C Digital inputs status
- D 4-digit display
- E SET push-button
- F +/- selection push-buttons

CONNECTIONS

M12 8-POLE CONNECTOR

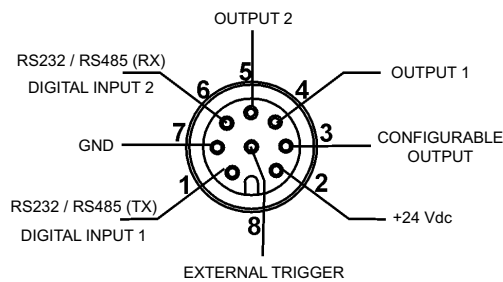

- | | |
|------------|--|
| 1 = white | = RS232 / RS485 (TX) / Digital input 1 |
| 2 = brown | = 24 Vdc |
| 3 = green | = Configurable output |
| 4 = yellow | = Output 1 |
| 5 = grey | = Output 2 |
| 6 = pink | = RS232 / RS485 (RX) / Digital input 2 |
| 7 = blue | = GND |
| 8 = red | = External trigger signal input |

M8 4-POLE CONNECTOR

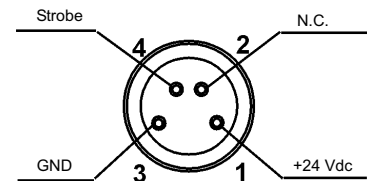

- | | |
|-----------|---------------------|
| 1 = brown | = +24 Vdc |
| 2 = white | = Not connected |
| 3 = blue | = GND |
| 4 = black | = Strobe TTL signal |



TECHNICAL DATA

Power supply:	24 Vdc $\pm 10\%$ ¹
Ripple:	2 Vpp max
Consumption:	120 mA at 24 Vdc
Output type:	2 PNP - NO
Output current:	100 mA max
Saturation voltage:	2 V
Processor:	Intel PXA 400 Mhz
Flash memory:	16 MB
RAM:	64 MB
Operating system:	Linux
Serial interface:	RS232 (115200 baud rate) RS485 (115200 baud rate)
Digital inputs:	2 digital in the digital input version (0/24 Vdc)
Auxiliary input:	trigger signal
Network interface:	Ethernet 10/100 Mbs
Image sensor:	CMOS 6.61mmx4.97mm 640x480 pixel resolution (VGA) 9.9 μ m pixel dimension
Optics:	CS-mount or C-mount with adapter
Electronic shutter:	global shutter
Acquisition time:	6 ms (full frame VGA 640x480)
Setting:	SET push-button + and - push-buttons auxiliary PC graphic user interface
Indicators:	4 digit display 3 green LEDs 1 yellow OUTPUT LED
Connections:	RJ45 Ethernet connector M12 8-pole I/O connector M8 4-pole external light connector
Electronic protection:	Class 2
Mechanical protection:	IP40
Protection devices:	A, B
Housing material:	aluminium alloy
Weight:	300 g without illuminator 385 g with integrated illuminator
Operating temperature:	-10 ... +55°C
Storage temperature:	-25 ... +70°C

TECHNICAL NOTES

¹ Limit values

² A - reverse polarity protection

B - overload and short-circuit protection



OPERATING CHARACTERISTICS

To simplify the activities of the developer, DATASENSOR has developed a graphic interface that allows an automatic connection with the telecamera and the visualisation of the images acquired during inspection.

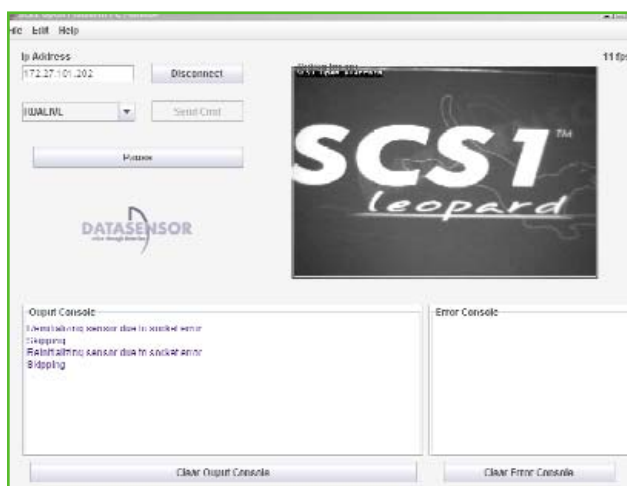

From an operating point of view, the C/C++ language is used for programming. The operating system installed on the SCS1 device is Linux for embedded systems that includes a kernel Linux, version 2.4.18.

The hardware characteristics are the same as the standard SCS1 and, in particular, the system is equipped of an Intel XScale PXA 400 Mhz processor, with 16MB Flash memory and 64 MB RAM, CMOS 640x480 grey-scale image sensor, serial outputs (RS232, RS485 for respective models), 2 outputs and 4 digital inputs.

MODEL SELECTION AND ORDER INFORMATION

MODEL	DESCRIPTION	ORDER N°
SCS1-00-PPZ2-NIL-OP	No illuminator, no optics, RS232 serial, Open Platform	959901120
SCS1-00-PPZ2-NIL-DK	No illuminator, no optics, RS232 serial, Development Kit	959901130

ACCESSORY SELECTION AND ORDER INFORMATION

MODEL	DESCRIPTION	ORDER N°
SIL-LINE RED FLOOD	Linear smart illuminator, red light with integrated LED driver	95A901180
SIL-AREA RED FLOOD	Rectangular smart illuminator, red light with integrated LED driver	95A901190
SIL-RING RED FLOOD	Ring smart illuminator, red light without integrated LED driver	95A901200
SIL-BACK RED	Backlight smart illuminator, red light without integrated LED driver	95A901210
SIL-SPOT RED FLOOD	Focussed smart illuminator, red light with integrated LED driver	95A901220
SIL-SPOT-NA RED FLOOD	Focussed smart illuminator, red light without integrated LED driver	95A901230
SIL-LINE WHITE FLOOD	Linear smart illuminator, white light with integrated LED driver	95A901260
SIL-AREA WHITE FLOOD	Rectangular smart illuminator, white light with integrated LED driver	95A901270
SIL-RING WHITE FLOOD	Ring smart illuminator, white light without integrated LED driver	95A901280
SIL-BACK WHITE	Backlight smart illuminator, white light without integrated LED driver	95A901290
SIL-SPOT WHITE FLOOD	Focussed smart illuminator, white light with integrated LED driver	95A901300
SIL-SPOT-NA WHITE FLOOD	Focussed smart illuminator, white light without integrated LED driver	95A901310
LD1	LED driver for SIL-SPOT-NA and SIL BACK	95A901240
LD2	LED driver for SIL-RING	95A901250
SCS-B1-02-G-01	1 m cable for illuminator, M8 4-pole connector	95A901070
SCS-CV-RJ45D-02	Ethernet cable direct 2 m *	95A901030
SCS-CV-RJ45C-03	Ethernet cable crossed 3 m **	95A901040
CS-A1-06-B-03	M12 8-pole connector with 3 m unshielded cable	95ACC2230
CS-A1-06-B-05	M12 8-pole connector with 5 m unshielded cable	95ACC2240
CS-A1-06-B-10	M12 8-pole connector with 10 m unshielded cable	95ACC2250
SCS-LE-V06-C-V	6 mm C-mount optics	95A901080
SCS-LE-V08-C-V	8 mm C-mount optics	95A901090
SCS-LE-V12-C-V	12 mm C-mount optics	95A901100
SCS-LE-V16-C-V	16 mm C-mount optics	95A901110
SCS-FILTER-620	optic filter 620 nm	95A901140
SCS-LASER POINTER	laser pointer for alignment	95A901050
SCS-ST5047	linear adjustable fixing bracket	95A901000
SCS-ST5048	angled adjustable fixing bracket	95A901020

* direct Ethernet cable for SCS and LAN network connection

** crossed Ethernet cable for SCS and PC connection

Distributed by:

**HEADQUARTERS****DATASENSOR SpA**

via Lavino, 265 - 40050 Monte San Pietro, BO - Italy
 Tel. +39 051/6765611 • Fax +39 051/6759324
www.datasensor.com • e-mail info@datasensor.com

Datasensor SpA endeavours to continuously improve and renew its products; for this reason the technical data and contents of this catalogue may undergo variations without prior notice. For correct installation and use Datasensor SpA can guarantee only the data indicated in the instruction manual supplied with the products.

SMART CAMERA SENSORS