

### Order example

**MCSH – 10 – 60**

MODEL

TUBE I.D.

STROKE

### Cylinder weight

Unit: g

Stroke (mm)	Tube I.D.			
	ø6	ø10	ø16	ø20
5	62	117	216	437
10	67	125	227	455
15	76	140	247	486
20	81	148	258	505
25	91	162	279	542
30	96	170	290	560
40	111	192	323	597
50	125	215	353	656
60	140	238	386	700

### Features

- Compact precision cylinder.
- Cylinder can take high lateral loads and is also non rotating.
- Cylinder can be mounted in 3 or 4 positions.
- Magnetic as standard.

### Specification

Model	MCSH			
Acting type	Double acting			
Tube I.D. (mm)	6	10	16	20
Guide rail width (mm)	5	7	9	12
Port size	M5×0.8			
Medium	Air			
Min. operating pressure	0.12 MPa	0.06 MPa	0.05 MPa	
Max. operating pressure	0.7 MPa			
Proof pressure	1.07 MPa			
Ambient temperature	-10~+60°C (No freezing)			
Operating speed range	50~500 mm/sec			
Allowable kinetic energy J (kgf · cm)	0.125	0.25	0.5	1.0
Lubricator	Not required			
Cushion	Rubber bumper			
Stroke length tolerance	+1.0 0			
Sensor switch (*)	RCE, RCE1, RDEP			

\* RCE, RCE1, RDEP specification, please refer to page 8-10, 15.

### Table for standard stroke

Tube I.D.	Stroke (mm)
ø6, 10, 16, 20	5, 10, 15, 20, 25, 30, 40, 50, 60

### Theoretical force

Unit: N

Tube I.D. (mm)	Piston rod (mm)	Operating direction	Piston area (mm <sup>2</sup> )	Operating pressure (MPa)		
				0.3	0.5	0.7
6	3	OUT	28.3	8.49	14.2	19.8
		IN	21.2	6.36	10.6	14.8
10	4	OUT	78.5	23.6	39.3	55.0
		IN	66.0	19.8	33.0	46.2
16	6	OUT	201.0	60.3	101.0	141.0
		IN	172.0	51.6	86.0	121.0
20	8	OUT	314.0	94.2	157.0	220.0
		IN	264.0	79.2	132.0	185.0

$\varnothing 6, \varnothing 10$

$\varnothing 16, \varnothing 20$

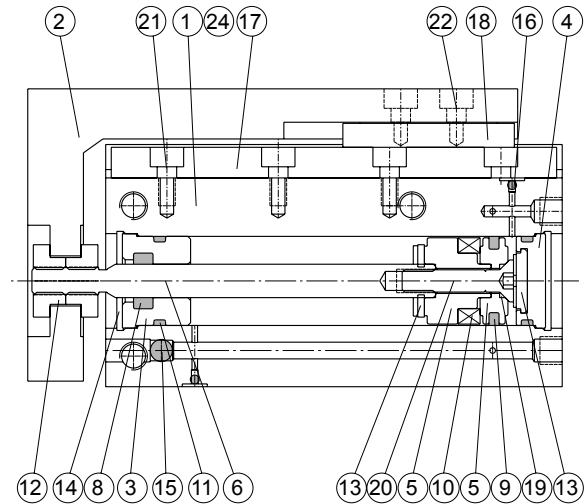
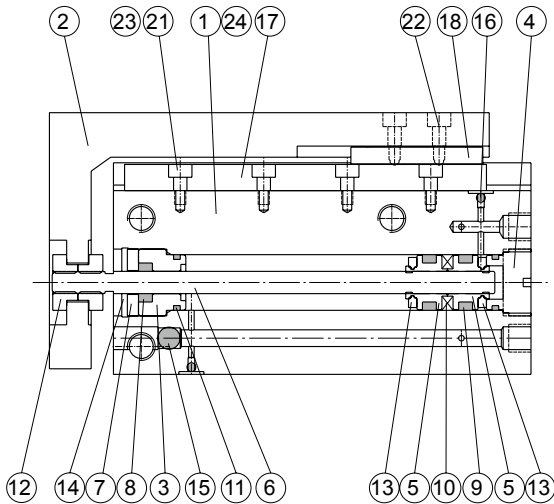

### Material

No.	Tube I.D. Part name	Tube I.D.				Note	Q'y	Repair kits (inclusion)
		6	10	16	20			
1	Body	Aluminum alloy				Anodized	1	
2	Table	Aluminum alloy				Anodized	1	
3	Rod cover	Aluminum alloy				Anodized	1	
4	Head cover	Aluminum alloy				Anodized	1	
5	Piston	Aluminum alloy					2	
6	Piston rod	Stainless steel					1	
7	Washer	*1		—		1		
8	Rod packing	NBR					1	●
9	Piston packing	NBR				Tube I.D. $\varnothing 6, \varnothing 10 \times 2, \varnothing 16, \varnothing 20 \times 1$	1 or 2	●
10	Magnet ring	Magnet material					1	
11	Cover ring	NBR					2	●
12	Rod front nut	Brass					2	
13	Cushion packing	NBR					2	●
14	C type snap ring for hole	Spring steel				Tube I.D. $\varnothing 6, \varnothing 10 \times 1, \varnothing 16, \varnothing 20 \times 2$	1 or 2	
15	Steel ball A	Stainless steel					1	
16	Steel ball B	Stainless steel					2	
17	Linear guide	Stainless steel					1	
18	Guide seat	Stainless steel					1	
19	Piston gasket	NBR		—		1	●	
20	Piston bolt	SCM		—		1		
21	Hexagon socket head cap screw A	Stainless steel				Tube I.D. $\varnothing 10 \sim 20$ (*2)	2~5	
22	Hexagon socket head cap screw B	Stainless steel				Tube I.D. $\varnothing 6 \times 2, \varnothing 10 \sim 20 \times 4$	2 or 4	
23	Round head Phillips screw	Stainless steel				only for tube I.D. $\varnothing 6$ (*2)	2~5	
24	Hexagon socket head plug	Stainless steel					4	
25	Plug gasket	NBR					4	●

\*1. Aluminum alloy

\*2. Quantity varies depending on the stroke length.

### Order example of repair kits

Tube I.D.	Repair kits
$\varnothing 6$	PS-MCSH-6
$\varnothing 10$	PS-MCSH-10
$\varnothing 16$	PS-MCSH-16
$\varnothing 20$	PS-MCSH-20

$\phi 6$

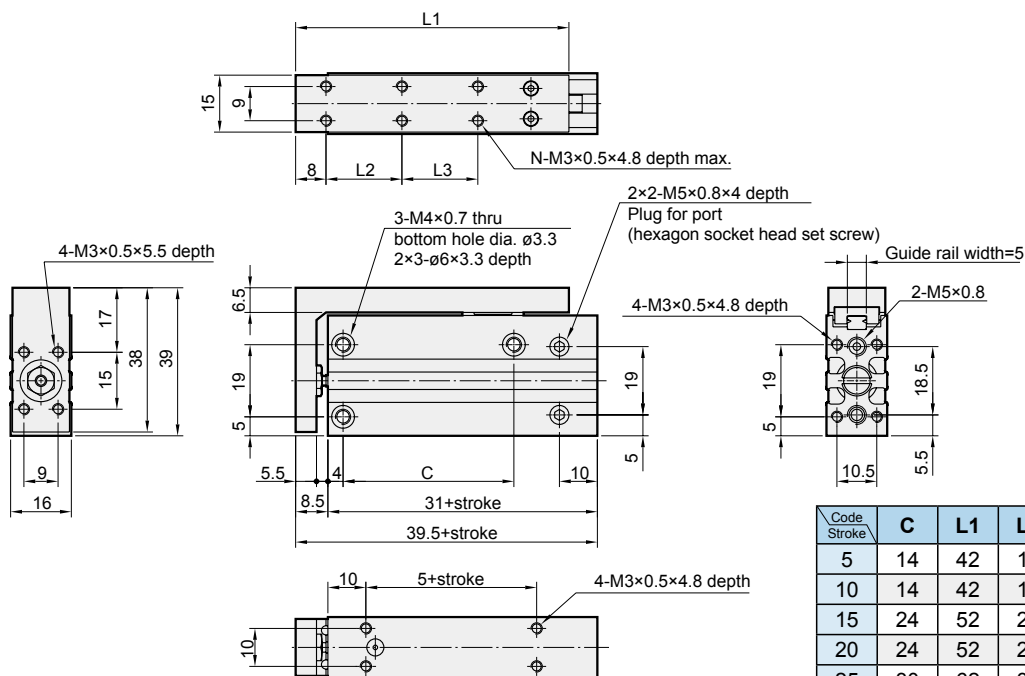

Code Stroke	C	L1	L2	L3	N
5	14	42	10	-	4
10	14	42	10	-	4
15	24	52	20	-	4
20	24	52	20	-	4
25	30	62	30	-	4
30	30	62	30	-	4
40	45	72	20	20	6
50	55	82	25	25	6
60	60	92	30	30	6

$\phi 10$

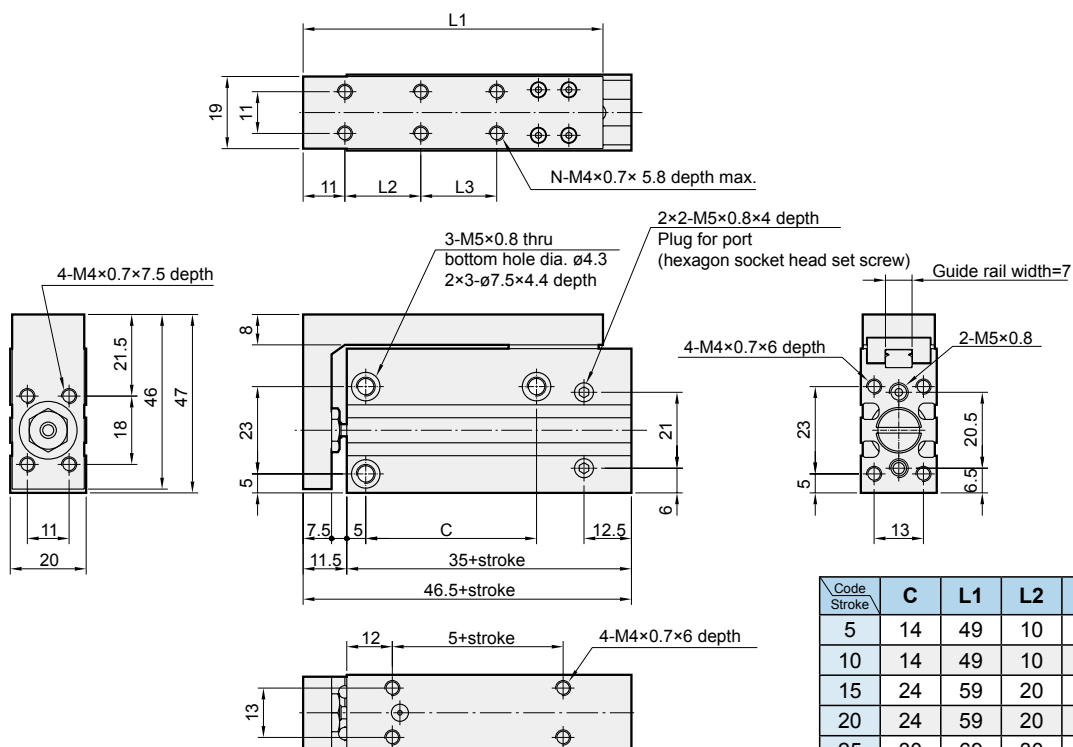

Code Stroke	C	L1	L2	L3	N
5	14	49	10	-	4
10	14	49	10	-	4
15	24	59	20	-	4
20	24	59	20	-	4
25	30	69	30	-	4
30	30	69	30	-	4
40	45	79	20	20	6
50	55	89	25	25	6
60	60	99	30	30	6

### $\phi 16$

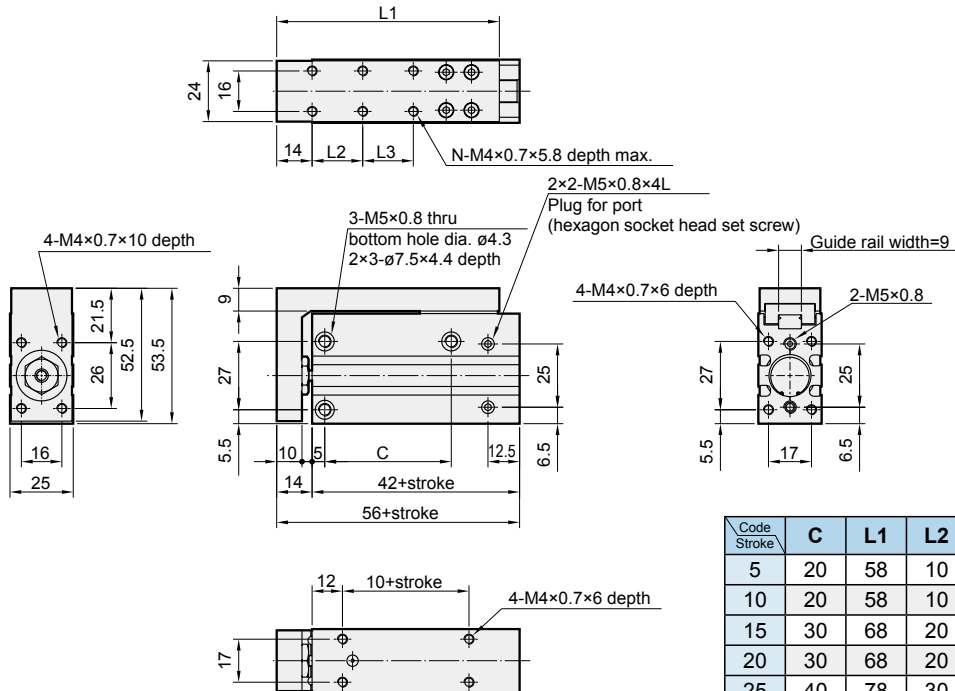

Code Stroke	C	L1	L2	L3	N
5	20	58	10	-	4
10	20	58	10	-	4
15	30	68	20	-	4
20	30	68	20	-	4
25	40	78	30	-	4
30	40	78	30	-	4
40	50	88	20	20	6
50	60	98	25	25	6
60	60	108	30	30	6

### $\phi 20$

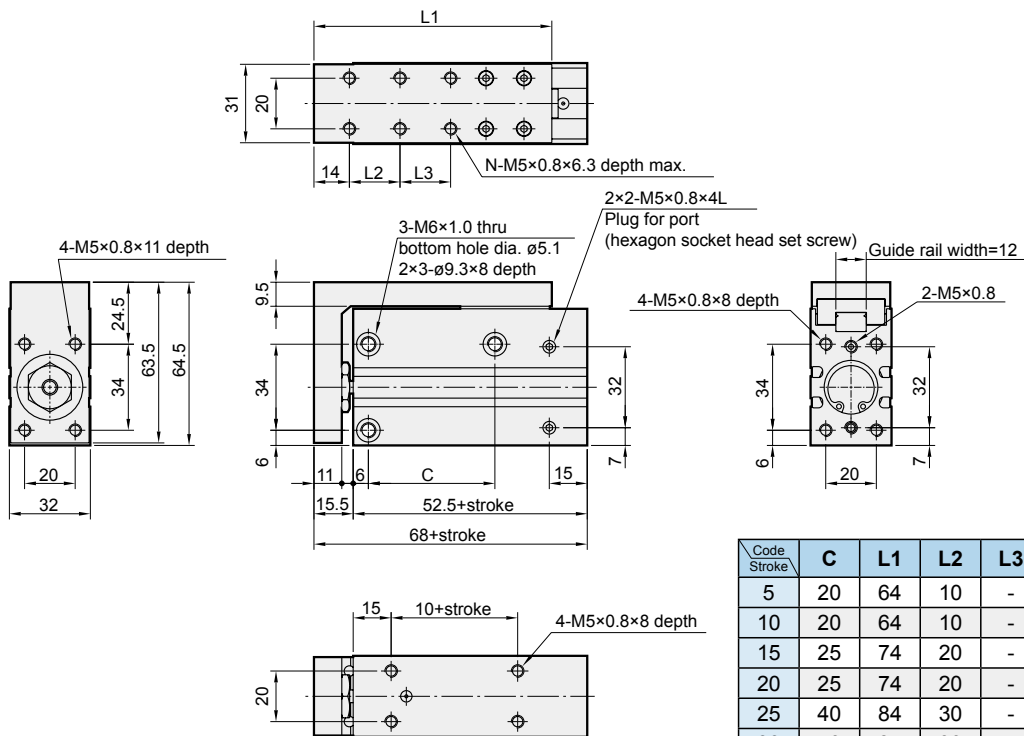

Code Stroke	C	L1	L2	L3	N
5	20	64	10	-	4
10	20	64	10	-	4
15	25	74	20	-	4
20	25	74	20	-	4
25	40	84	30	-	4
30	40	84	30	-	4
40	50	94	20	20	6
50	70	104	25	25	6
60	70	114	30	30	6