



ultrasonic sensing



LPU-2127

Loop Powered Ultrasonic Level Sensor

- 1 to 25 ft. (0.3 to 7.6 m) detection range on liquids
- 1 to 10 ft. (0.3 to 3 m) detection range on solids
- Low-power continuous level measurement
- Works on solids or liquids
- Integrated keypad and LCD display
- Loop-powered 4-20 mA output
- Easy to install
- Internal temperature compensation
- Rugged PDVF (Kynar®) transducer housing
- PET sensor housing
- Maintenance free

■ Description

The LPU-2127 sensor uses ultrasonic technology to provide a non-contact method of determining distance or level measurements. This versatility makes the LPU-2127 ideal for a variety of applications. The color/translucency, dielectric constant, specific gravity or viscosity of the target does not affect an ultrasonic sensor. Ultrasonic sensors function extremely well in harsh environments, are reliable, and require little or no maintenance.



■ Operational Description

Ultrasonic sensing is very similar to radar. The sensor transmits ultrasonic sound waves. If the sound waves meet a solid or reflective object, such as a liquid, they are reflected back and detected by the sensor. The time of flight is measured, and since the speed of sound is a well-known variable, the distance to the object can be calculated.

Until recently, the many variables in the speed of sound created inaccurate readings. With the advent of microprocessor technology, these variables can now be factored into the equation and eliminated. One such variable is ambient temperature. The LPU-2127 incorporates internal temperature compensation to adjust for changes in ambient temperature. The LPU-2127 also incorporates programmable filtering options to account for other variables, such as waves on a liquid or tank irregularities.

The distance to the object is converted into an analog output signal that is user adjustable.

■ Applications

The LPU-2127 was specifically designed for tank/bin level measurement and environmental monitoring, but is suitable for many other applications.



ultrasonic sensing

■ Specifications

Operating Range:
1 to 25 ft. (0.3 to 7.6 m) on liquids
1 to 10 ft. (0.3 to 3 m) on solids
Output: 4-20 mA (loop-powered)
600 ohms @ 24 VDC
150 ohms @ 12 VDC
Supply Voltage: 12 to 28 VDC (loop current 4-20 mA)
Total Current Draw: 4-20 mA
Housing: PDMF (Kynar®) transducer housing; PET upper housing
Mounting: 2 in. NPT
Transducer Type: Ceramic, PDMF faced
Ratings: IP65
Approvals:
CSA: Class I, Div. 2, Groups C & D;
CSA: Class I, Div. 2, AEx nA IIB T6, IP65
Response Time: Output dependant on output ranges from 0.6 to 3 sec.
Resolution: 0.1 in. (2.5 mm)
Accuracy: ±0.25% of detected range
Adjustments: Integrated keypad and LCD display
Operating Temperature: -40 to 140°F (-40 to 60°C)
Temperature Compensation: Internal
Beam Pattern: 9° off axis
Cable Connection: 2-terminal connector
Frequency: 69 kHz

Specifications are subject to change without notice.

■ Dimensions — in./mm

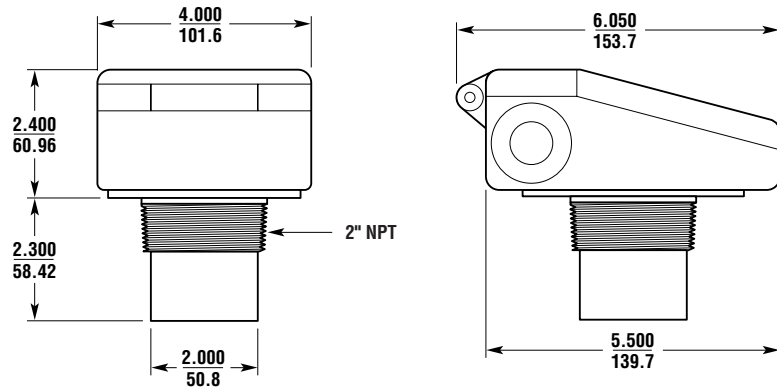

■ Wiring

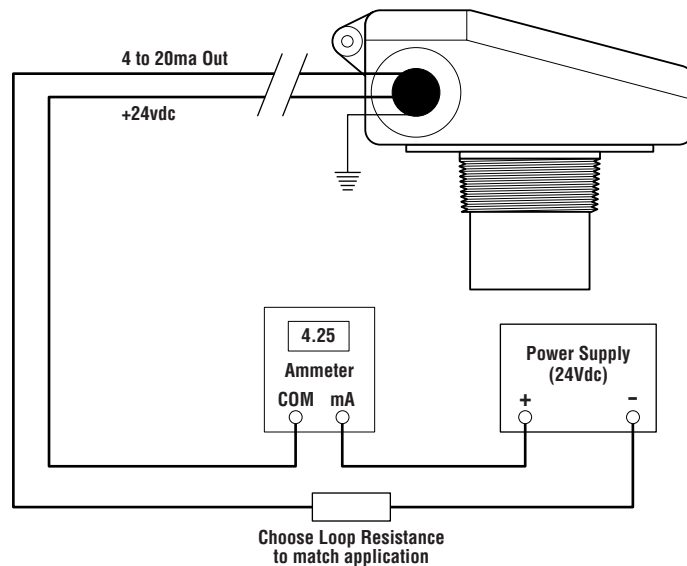

■ Ordering Information

Configuration	LPU -
2127	Loop powered ultrasonic level sensor

For information on ultrasonic sensing accessories, see page A24.

For the Latest Information
Try Our Fax Back System at **1/916/431-6544**
On the Internet: www.stiapg.com E-mail: sales@stiapg.com