



liquid level sensing



KA

Cable Suspended Float Level Sensors

- Usable in most liquids
- No mercury; no lead
- Installation does not require penetration of tank wall
- Adjustable switch point levels
- Choice of 16 standard models
- Highly chemical resistant
- Proven reliability in operation
- No maintenance required
- Cost effective



■ Operational Description

The KARI float switches are unique cable suspended liquid level sensors offering convenience and reliability for a wide range of pump control and alarm applications. Their most

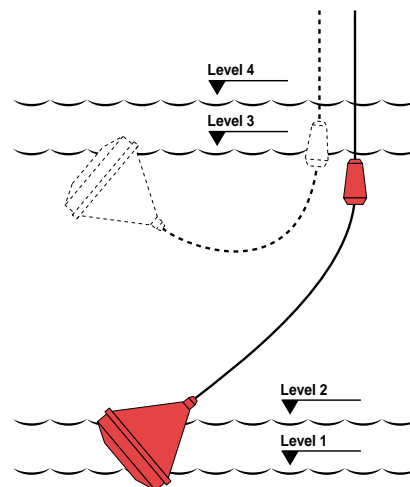

important feature is the ability to sense multiple levels using only one float. This results in a simple device that can be used in many different level sensing situations. The dependability of KARI float switches has been proven in many thousands of installations, worldwide, for over a quarter of a century.

These sensors come in sixteen different configurations to suit various applications. Details of the various models are given in the specification section.

KARI sensors consist of a free floating switch enclosure with an attached, jacketed, multiconductor cable. Inside the float, up to three heavy duty miniature

switches are cast at different angles. A control weight is fixed at a point along the cable. As the liquid level rises and falls, the weight on the cable causes the inclination of the float to change.

This tilting action causes the miniature switches to open and/or close at different levels. The switch operating levels are easily adjusted by moving the weight along the cable and/or altering the length of the cable.

The hermetically sealed switch enclosure is conical in shape, filled with plastic foam and weighted on one side. The rugged float and the weight are made of chemical resistant polypropylene. The standard cable is PVC covered.

There are two versions of the KARI sensor. The standard S series units are larger and have greater capabilities than the smaller M (miniature) series units.

■ Applications

There are many possible uses for these sensors since they can operate in practically any liquid. They are unaffected by floating material or by fluid characteristics (density, color, suspensions, mixtures, coating properties, etc.). They work well in viscous media. By having a separation between the switching levels, problems caused by turbulence are overcome.

Sixteen different configurations allow control circuitry to be simplified. Normally a "make" (closure) is used to activate an alarm or start an action and a "break" (opening) is used to stop

the action. Installation is extremely simple because KARI level sensors are designed to hang freely in the tank from a single fixing point. Operating levels are easily adjusted.

■ Single Versus Dual Point Control

The simplest single point KARI level sensors (Models 1L or 1H) switch ON and OFF at one level. Such sensors work well as alarm point indicators but are unsuitable for maintenance of liquid levels in a container.

Tank levels are usually maintained by pumps or electrically controlled solenoid valves in the supply or drain

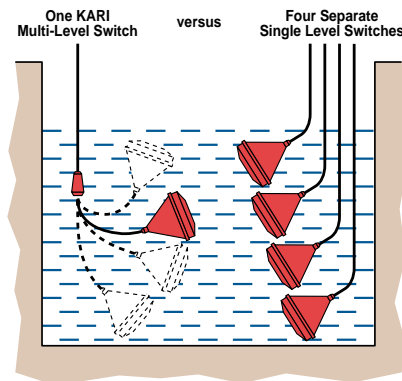

lines. Holding the level exactly at one point is difficult if there is flow in and out of the container, because it would involve the control switch going on and off constantly. This leads to excessive pump wear. Thus, the normal practice is to have two control levels involved (hysteresis or dead band). At one level the pump or valve is turned on, and at the other level it is turned off.

These situations take advantage

of the unique capabilities of the KARI float level sensors. Rather than using two separate single level float switches, one float switch (models 2L or 2H) can provide a latching circuit between the ON and OFF levels. This differential can be easily adjusted from 10 inches to 50 inches. Other KARI level sensors provide additional facilities for high and low alarms as well as control of duplex pump systems.

■ Chemical Compatibility — Corrosion Resistance of Materials

With a standard KARI level sensor, the only materials in contact with the liquid are the polypropylene float and weight, the polyethylene wedge, and the heavy duty PVC covered cable.

Consequently, these switches are unaffected by a wide range of liquids. However, some liquids are not compatible with these materials. For such applications, optional cable materials, (PTFE and polyurethane) are available. In assessing corrosion, key factors are the liquid temperature and concentration, and the amount of time the float is immersed (see Chemical Compatibility appendix for details). Even if periodic replacement of KARI float switches is necessary, they still may be the most economical choice. ATON® rubber cables are preferred for applications where freezing conditions can occur. TPU cables are recommended for petroleum based media. PVC covered cables tend to stiffen in low temperatures and also to absorb petroleum based media.



liquid level sensing



For the Latest Information

Try Our Fax Back System at 1/916/431-6544

On the Internet: www.stiapg.com E-mail: sales@stiapg.com

■ Operating Levels

The diagram below illustrates the relationship between the switching levels, the spacing of the weight along the cable, and the height of the fixing point. For multi level switches, there are some restrictions on the different elevations that can be selected.

There is a minimum standard switching level difference of 10 in. for the basic two level switch. This differential can be increased by moving the weight farther away from the float. The level of these switching points

■ Cable Weights

Single level switches (high or low alarm) are not supplied with weights. All multiple level switches are supplied with standard weights. Heavier weights may be needed if there is a danger of caking, thick crusts developing and/or if the liquid is very dense and viscous. Contact STI for details.

Alternative weights available are:

Type	Color	Weight
Type A	Black	0.75 lb.. (400 g)
Type B	Red	1.5 lb. (800 g)
Type C	Grey	2.25 lb. (1 kg)

■ Cable Length

The standard cable length is 16 ft. (5 m). An optional length of 50 ft. (15 m) is also available from stock.

Standard units have heavy duty cables with PVC covering. Typical diameters and weights of the cables are:

	Dim	Wt/5M
2 Wires	0.25 in.	275 or 350 g
3 Wires	0.27 in.	338 g
4 Wires	0.31 in.	426 g
5 Wires	0.34 in.	515 g

Longer cables can be provided by special order. Once the cable is outside the liquid it can be easily extended through a waterproof junction box or liquid tight connector.



liquid level sensing

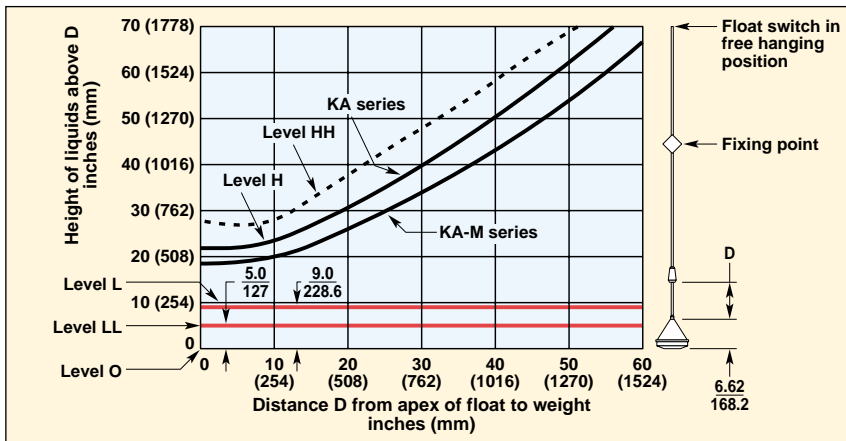

can be altered by changing the height at which the float hangs in the empty tank. The other two levels of a three function switch bear a fixed relationship to the above adjustments. If these need to be adjustable or the normal elevation ranges are unsuitable, a combination of switches can be used or a special switch can be ordered. For example, a 3HE can be replaced by a 2H working together with a 1H.

■ Specifications

Series	KA Series	KA-M Series
Contact Ratings		
Maximum Voltage:	250 VAC or DC	250 VAC or DC
Maximum AC Current (Resistive):	6 A	6 A
Maximum AC Current (Inductive):	3 A	3 A
Maximum DC Power:	75 VA (0.3 A @ 250 V)	75 VA (0.3 A @ 250 V)
Maximum Liquid Temperature ⁽¹⁾ :	140°F (60°C)	140°F (60°C)
Maximum Pressure (at 20°C):	28 psi (2 bar)	28 psi (2 bar)
Minimum Fluid Specific Gravity: (Water 1.0)	0.7	0.95
Standard Cable Length ⁽¹⁾ :	16 ft. (5 m)	16 ft. (5 m)
Switching Differential⁽¹⁾		
Minimum:	10 in.	10 in.
Maximum:	50 in.	40 in.
Ratings:	IP67 (NEMA 6)	IP67 (NEMA 6)
Maximum Number of Switching Levels:	4	2
Maximum Number of Wires in Cable:	5	2
Standard Weight Type ⁽²⁾ :	A (black-0.75 lb.)	A (black-0.75 lb.)

⁽¹⁾ See options available. ⁽²⁾ On floats with more than one switch point. Specifications are subject to change without notice.

■ **Importance Of Control Relays**

The contacts used in KARI float switches are high performance miniature switches, although they are capable of carrying moderate currents at up to 250 VAC. Because they are immersed in a liquid, it is not a good practice to switch pump motor currents directly through these contacts. Therefore, it is usually just low currents for relay coil operation that are applied to the float switch contacts. The contact rating of the KARI switches should never be exceeded.

Relays with heavy duty contacts are known as contactors. Pump motor manufacturers often provide suitable contactors with the control circuits on their motors. These allow the KARI float switches to be connected directly. If contactors are not provided, the contact ratings needed to start and stop a pump should be thoroughly understood. When pump motors start and stop, they can produce momentary surge currents several times greater than the steady running current. Suppliers of relays and contactors usually provide maximum ratings for their contacts in terms of allowable pump motor horsepower figures.

■ **Hazardous Locations; Intrinsic Safety**

KA series switches do not carry hazardous area ratings. Since they are simple switches with no active electronic components, they can be used in hazardous locations provided they are operated in conjunction with **appropriately rated and installed intrinsically safe barriers**.

The technique of intrinsic safety is an alternative approach to explosion proofing. The traditional method of preventing explosions in hazardous environments is based on placing all electrical circuits and components in heavy boxes and conduit so that if an explosion is sparked by the electrical circuit, it

will be contained and not escape into the hazardous area. With intrinsic safety, special circuits and barriers are built into the external equipment so that any wiring running into the hazardous location do not have sufficient voltage and current (hence power) to cause an explosion. Typical intrinsically safe configurations for KA series switches are illustrated below.

Customers requiring additional information on electrical requirements for hazardous locations should contact their local electrical fire and building authorities.

Also see STI Intrinsic Safety information on the website at: stiapg.com/0825 and stiapg.com/7150.



liquid level sensing

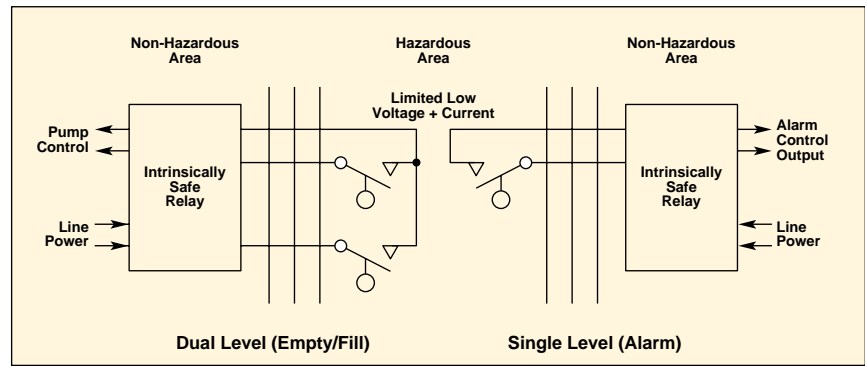

■ **Dimensions — in./mm**

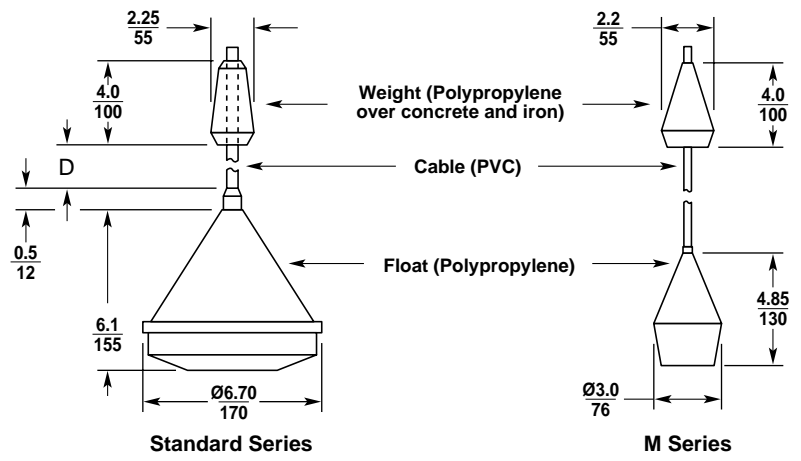

 **For the Latest Information**
Try Our Fax Back System at **1/916/431-6544**
On the Internet: www.stiapg.com E-mail: sales@stiapg.com

■ **Typical KA Series Applications**

Model 1H and 3H

Control of alternating emptying pumps with high level alarm.

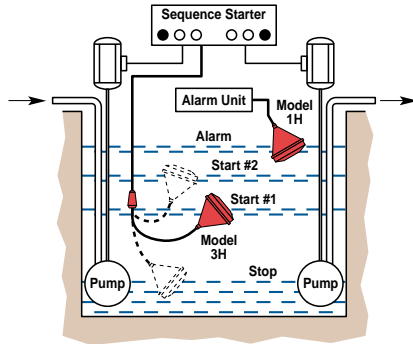

Model 4H

Control of emptying pumps with high and low level alarms.

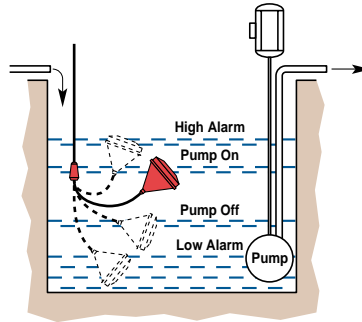

Model 2HL or M2AY

Control of both high and low level alarms.

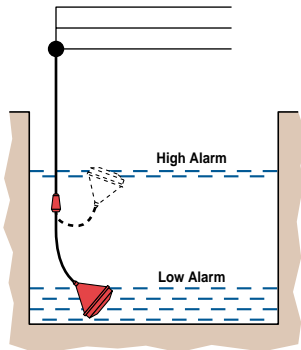

Model 4L5E

Control of alternating filling pumps with low level alarm.

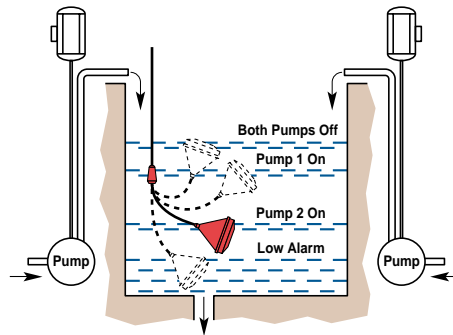

Model 3HE

Emptying pump control with high level alarm.

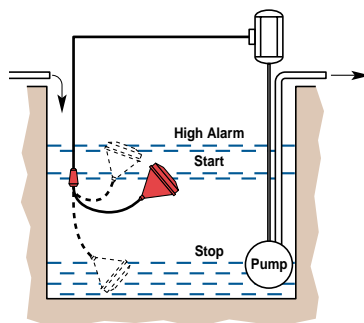

Options

- Higher working temperature to 175°F (80°C)
- Custom cables to specified lengths
- Greater switching differentials to 75 in. (S Series) or 60 in. (M Series)
- Smaller switching differentials to 2 1/2 in.
- Alternative logic at switching points (NO or NC).
- Alternative cables in ATON® (rubber) and polyurethane
- Alternative cable in TPU
- Alternative cable in PTFE (max. 4 conductors for 3 or less switch points)
- Lead weight in place of polypropylene covered weight.

liquid level sensing

■ **Model Selection Table**

KARI float switches provide up to four separate switching levels in one conically shaped float. A weight on the cable is used to adjust the difference between switching points. Full details of

the different standard configurations are given in the table below. For installation and additional application details, ask for the KA series owner manual.

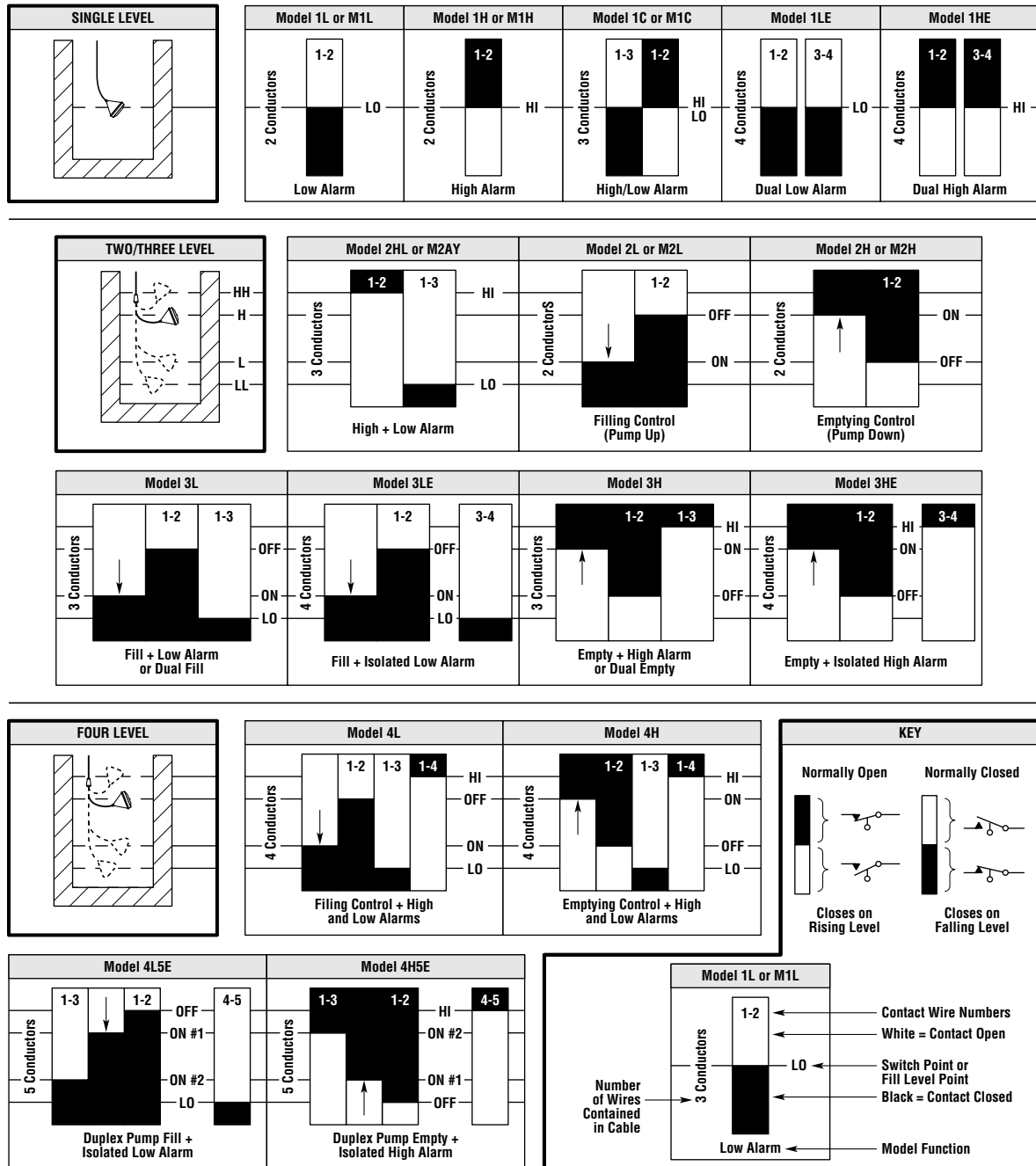

liquid level sensing



For the Latest Information
Try Our Fax Back System at **1/916/431-6544**
On the Internet: www.stiapg.com E-mail: sales@stiapg.com

■ **Typical Wiring Diagram for Dual Pumps Emptying with High Alarm Using KA-4H5E**

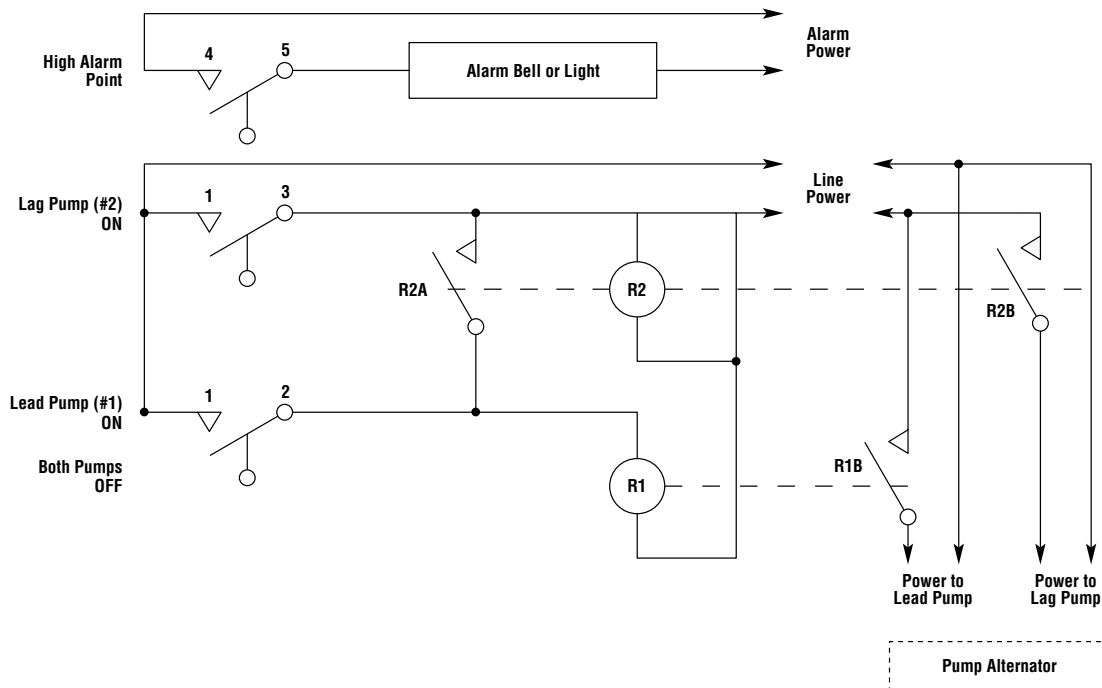

liquid level sensing

■ **Selecting the Right KA Series Switch**

KA series float switches provide up to four separate switching levels in one conically shaped float. A weight on the cable is used to adjust the difference between switching points. Full

details of the different standard configurations are given on the preceding page.

Sometimes combinations of switches may be needed to meet critical switching point elevations or multiple pump situations. Our Application Engineers will be pleased to assist users in selecting the best models/versions for their particular needs.

3. If no suspended solids are present, the specific gravity of the liquid is greater than 0.95 and no more than two separate switch points are needed, the smaller M series switches may be used.

4. If a special situation exists (material compatibility, special operating levels, etc.), a number of options are available.

5. For more detailed applications information and installation advice on KA series float switches request a copy of the Owner Manual.

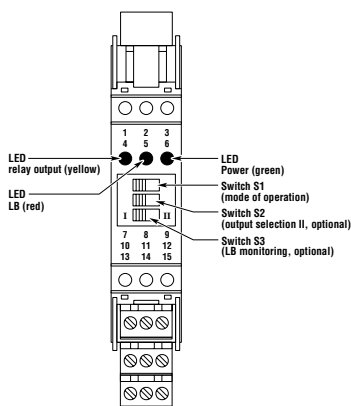

STI Intrinsic Safety Barrier

1. Determine number of level control points needed; for example, one point for alarm and two points for empty/fill operations.

2. Select required model.

■ **Ordering Information**

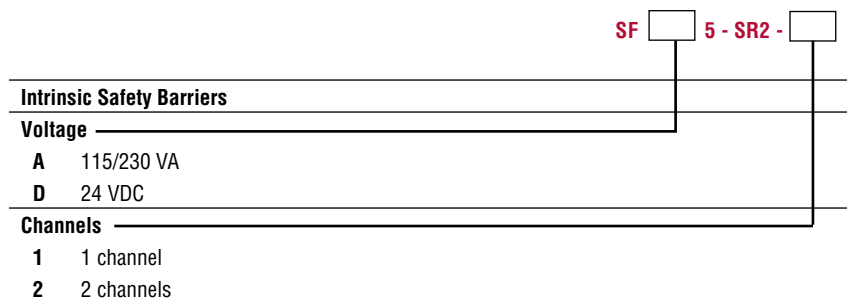
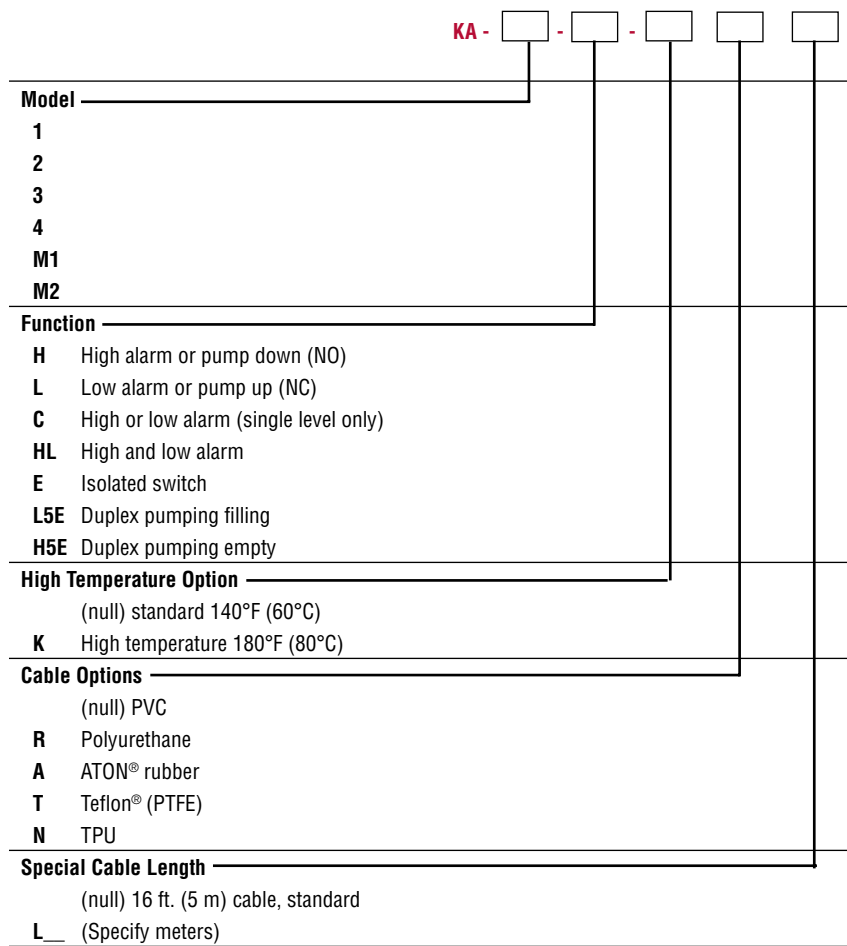

For the Latest Information

Try Our Fax Back System at **1/916/431-6544**
On the Internet: www.stiapg.com E-mail: sales@stiapg.com