

ELC Manual

Content.

- ✧ Introduction
- ✧ Getting started
- ✧ Installation and wiring
- ✧ Functions
- ✧ Configuring
- ✧ Applications
- ✧ Software
- ✧ Technical data

Introduction

Congratulations with your xLogic SuperRelay provided by Easy Electronic Co., Ltd.

The xLogic SuperRelay is a compact and expandable CPU replacing mini PLCs, multiple timers, relays and counters.

The xLogic SuperRelay perfectly fits in the space between timing relays and low-end PLCs. Each CPU incorporates not only a real-time clock and calendar, but also provides support for optional expansion I/O modules to enhance control and monitoring applications. Data adjustments can easily be performed via the keypad, the LCD display, or through the easy-to-use xLogic software. DIN-rail and panel mounted options are both available, offering full flexibility to the various installation needs of your application.

The xLogic SuperRelay is available in 120V/240V AC or 12V and 24V DC versions, making it the ideal solution for relay replacement, or simple control applications as building and parking lot lighting, managing automatic lighting, access control, watering systems, pump control, ventilation systems, home automation and a wide field of other applications demanding low cost to be a primary design issue.

We strongly recommended taking the time to read this manual, before putting the xLogic SuperRelay to work. Installation, programming and use of the unit are detailed in this manual. The feature-rich xLogic SuperRelay provides a for off-line operation mode, allowing full configuration and testing prior to in-field service commissioning. In reviewing this manual you will discover many additional advantageous product properties, it will greatly simplify and optimize the use of your xLogic SuperRelay.



Valid range of this manual

The manual applies to devices of series ELC-18 and ELC-12 and ELC-E.

Safety Guideline

This manual contains notices you have to observe in order to ensure your personal safety, as well as to prevent damage to property. The notices referring to your personal safety are highlighted in the manual by a safety alert symbol, notices referring to property damage only have no safety alert symbol. The notices shown below are graded according to the degree of danger.

Caution

Indicates that death or severe personal injury may result if proper precautions are not taken



Caution

With a safety alert symbol indicates that minor personal injury can result if proper precautions are not taken.



Caution

Without a safety alert symbol indicates that property damage can result if proper precautions are not taken.



Attention

Indicates that an unintended result or situation can occur if the corresponding notice is not taken into account.



If more than one degree of danger is present, the warning notice representing the highest degree of danger will be used. A notice warning of injury to persons with a safety alert symbol may also include a warning relating to property damage.



Qualified Personnel

The device/system may only be set up and used in conjunction with this documentation. Commissioning and operation of a device/system may only be performed by qualified personnel. Within the context of the safety notices in this documentation qualified persons are defined as persons who are authorized to commission, ground and label devices, systems and circuits in accordance with established safety practices and standards.

Prescribed Usage

Note the following:

Warning

This device and its components may only be used for the applications described in the catalog or the technical description, and only in connection with devices or components from other manufacturers which have been approved or recommended by EASY. Correct, reliable operation of the product requires proper transport, storage, positioning and assembly as well as careful operation and maintenance.

Trademarks

All names identified by xLogic are registered trademarks of the EASY. The remaining trademarks in this publication may be trademarks whose use by third parties for their own purposes could violate the rights of the owner.

Copyright Easy 2007 all rights reserved

The distribution and duplication of this document or the utilization and transmission of its contents are not permitted without express written permission. Offenders will be liable for damages. All rights, including rights created by patent grant or registration of a utility model or design, are reserved.

Disclaim of Liability

We have reviewed the contents of this publication to ensure consistency with the hardware and software described. Since variance cannot be precluded entirely, we cannot guarantee full consistency. However, the information in this publication is reviewed regularly and any necessary corrections are included in subsequent editions.



Contents

1. General Introduction to xLogic	8
2. Installation/remove xLogic.....	18
2.1 DIN rail mounting.....	19
2.2 Wiring the xLogic.....	20
2.2.1 Connecting the power supply.....	20
2.2.2 Connecting xLogic inputs.....	21
2.2.3 Connecting xLogic outputs	24
3. Programming xLogic.....	26
3.1 General Input & Output functions.....	26
3.1.1 Inputs.....	26
3.1.2 Cursor keys.....	27
3.1.3 Outputs.....	27
3.1.4 Permanent logical levels HI and LO.....	27
3.1.5 Shift register bits.....	27
3.1.6 Analog inputs.....	28
3.2 Basic functions list – GF.....	28
3.2.1 AND.....	29
3.2.2 AND with edge evaluation.....	30
3.2.3 NAND.....	30
3.2.4 NAND with edge evaluation.....	31
3.2.5 OR.....	32
3.2.6 NOR.....	33
3.2.7 XOR.....	34
3.2.8 NOT.....	34
3.3 Basics on special functions.....	34
3.3.1 Designation of the inputs.....	35
3.3.2 Time response.....	36
3.3.3 Backup of the real-time clock	36
3.3.4 Retentivity	37
3.3.5 Parameter protection.....	37
3.3.6 Calculating the gain and offset of analog values.....	37
3.4 Special functions list – SF.....	39



3.4.1	On-delay.....	39
3.4.2	Off-delay.....	42
3.4.3	On-/Off-delay.....	43
3.4.4	Retentive on-delay.....	45
3.4.5	Wiping relay (pulse output).....	46
3.4.6	Edge triggered wiping relay.....	47
3.4.7	Asynchronous pulse generator.....	48
3.4.8	Random generator.....	49
3.4.9	Stairway lighting switch.....	50
3.4.10	Multiple function switch.....	52
3.4.11	Weekly timer.....	53
3.4.12	Yearly timer.....	55
3.4.13	Up/down counter.....	58
3.4.14	Hours counter.....	60
3.4.15	Threshold trigger.....	63
3.4.16	Latching relay.....	65
3.4.17	Pulse relay.....	66
3.4.18	Message text.....	67
3.4.19	Softkey.....	70
3.4.20	Shift register.....	71
3.4.21	Analog comparator.....	73
3.4.22	Analog threshold trigger.....	75
3.4.23	Analog amplifier.....	77
3.4.24	Analog value monitoring.....	78
3.4.25	Analog differential trigger.....	80
3.4.26	Analog multiplexer.....	82
3.4.27	Peripheral.....	84
3.5	HMI block.....	87
3.5.1	System cover.....	87
3.5.2	System input/output.....	88
4.	Configuring xLogic.....	90
4.1	Instruction of xLogic-HMI.....	90
4.2	Select function page.....	91
4.2.1	Run/Stop.....	93
4.2.2	Set parameter.....	94
4.2.3	Set password.....	97
4.2.4	Set Address of expansion module.....	101
4.2.5	Modification Methods of System Time.....	101
5.	Application.....	103
5.1	Dual-function switch.....	104
5.1.1	Standard solution.....	104
5.1.2	The scheme of xLogic.....	106
5.2	Automatic gate.....	107
5.2.1	Standard solution.....	108
5.2.2	The scheme of xLogic.....	109
5.3	Ventilation system.....	111
5.3.1	Standard solution.....	112
5.3.2	The scheme of xLogic.....	113



5.4 Factory door	115
5.4.1 Standard solution.....	116
5.4.2 The scheme of xLogic.....	116
5.5 Daylight lamp system	118
5.5.1 Standard solution.....	119
5.5.2 The scheme of xLogic.....	119
5.6 Rainwater pump	121
5.6.1 Standard solution.....	122
5.6.2 The scheme of xLogic.....	123
6. xLogic Software	124
6.1 Connecting the xLogic to a PC	148
Appendix	
A Technical data.....	149
A.1 General technical data.....	149
A.2 Technical data: xLogic (ELC series)	151
A.3 Relay switch life.....	153



1. General Introduction to xLogic

Overview

xLogic SuperRelay is a universal logic module made by Easy.

xLogic SuperRelay, a compact, expandable CPU that can replace mini PLC, multiple timers, relays and counters, Splitting the difference between a timing relay and a low-end PLC, Each CPU houses a real-time clock and calendar, and supports optional expansion I/O modules to enhance your control and monitoring applications . Data adjustments can be done via the on-board keypad and LCD display, or with xLogic soft. It can be either DIN-rail or panel mounted, depending upon the needs of your application, and it is available in 120V/240V ac as well as 12V and 24V dc versions, and it is the ideal solution for relay replacement applications, simple control applications such as building and parking lot lighting, managing automatic lighting, access control, watering systems, pump control, or ventilation systems in factory, and home automation and applications in which cost is a primary design issue.

Highligh features:

- 4-lines, 10-character per line, backlight display.
- Multiple value display and input via keypad and LCD display.
- Function Block Diagram
- Standard Modbus RTU communication protocol supported.
- CAN BUS protocol based expansion modules
- Expandable up to 31 linked modules reaching fast reacting 514 I/O points
- RS232 and RS485 port (expandable port of CPU unit).
- Long distance remote I/O
- Optional Ethernet connectivity
- SMS Alarm / Alert module
- SuperRelay accepts SMS programming
- SSI encoder interface module
- Supplies 8 analogue inputs with DC0-10V.
- Real Time Clock (RTC)
- Two channel high-speed counting (99Khz)
- Pre-configured standard functions, e.g. on/ off-delays, pulse relay and softkey
- 2 PWM channels
- RS232 communication download cable with photo-electricity isolation
- USB communication download cable with photo-electricity isolation
- Programmable capability up to 256 function blocks(ELC-18)
- Mounting via modular 35mm DIN rail or screw fixed mounting plate
- On-line monitor capability
- Compact design
- Low cost pricing



Some of the things xLogic can do for you?

The xLogic SuperRelay provides solutions for commercial, industrial, building and domestic applications such as lighting, pumping, ventilation, shutter operations or in switching cabinets. The application field is widespread and these are just a few to mention.

Using the CAN bus and Ethernet connectivity allows the user to realize various extensive (real-time) monitoring and control applications. Utilizing the optional SMS module the systems can furthermore be remotely controlled via (GSM) cell phone. SMS Alarms, status updates and any other desirable messages can be provided at set triggers.

Special versions without operator panel and display unit are available for series production applications in small machine, installation and cabinet building environments to further slash cost.

xLogic devices:

xLogic Basic is available in two voltage classes:

*Classes 1: DC12-24V: i.e.: ELC-18DC Series and ELC-12DC Series.

*Classes2:AC110-240V: i.e.: ELC-18AC Series and ELC-12AC Series

In the versions:

* With Display: ELC-18 Series (12 inputs and 6 outputs)

* Without Display: ELC-12 Series (8 inputs and 4 outputs)

ELC-18 Series is equipped with an expansion bus (Can Bus)

Each Version is provides 36 pre-configured standard and special function blocks for the creation of your circuit program.

Expansion modules:

* xLogic digital modules are available for operation with 12...24V DC, and 110.. .240 V AC, and are equipped with eight inputs and eight outputs.

* xLogic analog modules are available for operation with 12...24 V DC and are equipped with six digital and two analog inputs.

Communication modules:



- **xLogic:RS232 communication module (type:ELC-RS232)**

It is kind of universal module with photoelectricity isolation which can be directly connected to standard 9-pin port of PC, also kind of interface module which can enable user's program to be downloaded into xLogic main module through xLogicsoft for running.

- **xLogic: USB communication module (type: ELC-USB).**

It is kind of communication module with photoelectricity isolation through which PC with USB port only can be connected to xLogic main module, moreover, it has same features as ELC-RS232 module, so it is quite convenient for user whose computer has no standard serial port.

- **xLogic: Ethernet module (type: ELC-Ethernet)**

It is called Ethernet module, used to connect xLogic main modules in different places to enormous Ethernet to buildup a huge monitoring and control system. It contains DC and AC two types.

- **xLogic:SMS module (type: ELC-SMS)**

ELC-SMS is kind of SMS module, through which SMS can be regarded as expansion input by user to realize wireless remote control and it can send alarm messages to user cell phones.

Communication / Network

xLogic offers different ways to communicate within the system.

RS485 port

The RS485 port is used for communication between the main module and various devices or equipments which have the standard RS485 port .(only ELC-18 Series available, not applied to ELC-12 series) Communicate using Modbus RTU/ASCII protocol.

RS232 or USB port

If there is no network required and only one main module with some expansion modules is needed for the application, the down- and upload of the project to and from the main module happens over the standard RS232 or USB port. It allows system maintenance like monitoring too.



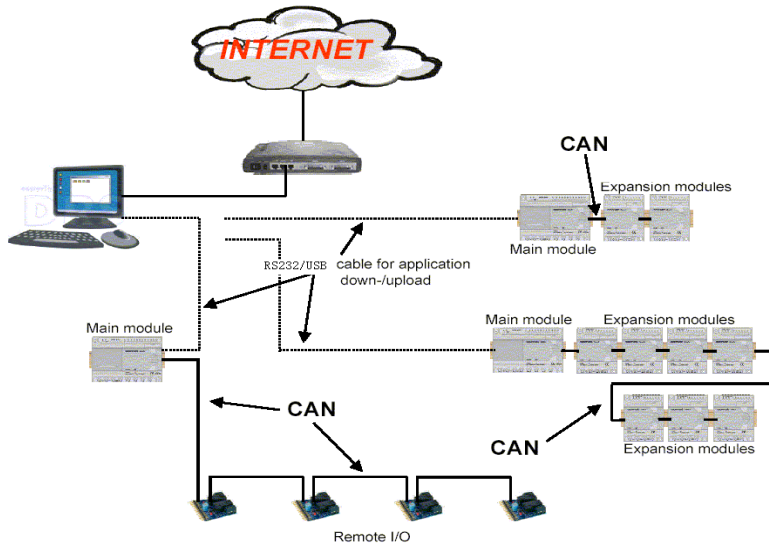

Ethernet network

If the application requires a system where more than one main module is needed and these main modules have to communicate, each main module will be connected over an Ethernet Module box to the Ethernet. The project down- and upload to and from the main modules and the communication between the main modules happens over the Ethernet network. Furthermore the visualization of the whole system is possible and easy to realize a personal computer.



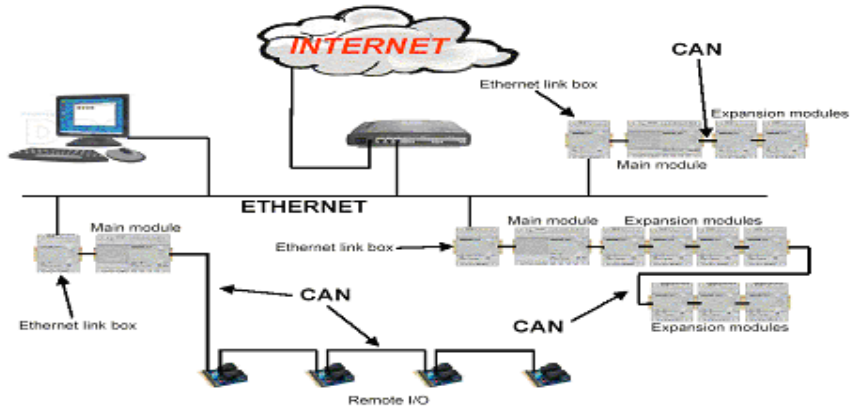

CAN bus

The communication between the main module and the expansion modules or the remote I/O happens over a CAN bus. CAN is a widely used bus system (only ELC-18 Series available, not applied to ELC-12 series)

Note

xLogic Main Module may be equipped with expansion modules of the different voltage class, but expansion module must be supplied the correct power corresponding to its type.

Each xLogic Main Module provides the following connections for the creation of the circuit program, regardless of the number of connected blocks:

- Digital inputs I1 to IC (ELC-18), I1 to I8(ELC-12).
- Analog inputs AI1 to AI8
- Digital outputs Q1 to Q6 (ELC-18), Q1 to Q4(ELC-12)
- Shift register bits S1 to S8
- 4 cursor keys



Naming Rules of ELC Series

Model name (main module) :

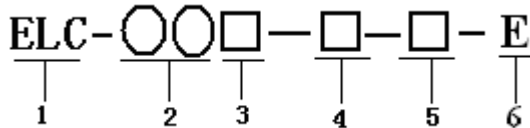

1. Series name
2. Points of input and output
3. Supply power AC or DC
4. Digital/Analog D: digital DA: digital/analog L: with photoelectricity isolation
5. Output format R: relay T: transistor
TN = "NPN" transistor; TP= "PNP" transistor
6. E: economic mode(only adapts to ELC-18)

Model name (expansion module):

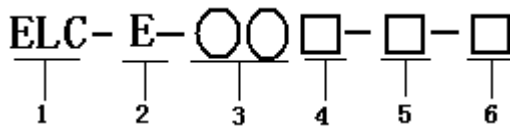

1. Series name
2. E: expansion module
3. Points of input and output
4. Supply power AC or DC
5. Digital/Analog D: digital DA: digital/analog
6. Output format R: relay TP: "PNP" transistor;



MODEL		DESCRIPTION						
ELC-12 CPU UNITS								
	Expansion	Supply voltage	Inputs	Outputs	PWM	HMI	RTC	High-speed count
ELC-12AC-R	No	AC110~AC240V	8 digital	4 relays (10A)	no	no	yes	1 Routes(99KHZ)
ELC-12DC-D-R	No	DC12-24V	8 digital	4 relays (10A)	no	no	yes	1 Routes(99KHZ)
ELC-12DC-D-TP	No	DC12-24V	8 digital	4 transistor (0.3A)	2 ch(Q3,Q4)	no	yes	1 Routes(99KHZ)
ELC-12DC-DA-R	No	DC12-24V	8 analog/digital	4 relays (10A)	no	no	yes	1 Routes(99KHZ)
ELC-12DC-DA-TP	No	DC12-24V	8 analog/digital	4 transistor (0.3A)	2 ch(Q3,Q4)	no	yes	1 Routes(99KHZ)

Standard ELC-18 CPU UNITS								
	Expansion	Supply voltage	Inputs	Outputs	PWM	HMI	RTC	High-speed count
ELC-18AC-R	available	AC110~AC240V	12 digital	6 relays (10A)	no	yes	yes	2 Routes(99KHZ)
ELC-18DC-D-R	available	DC12-24V	12 digital	6 relays (10A)	no	yes	yes	2 Routes(99KHZ)
ELC-18DC-D-TP	available	DC12-24V	12 digital	6 transistor (0.3A)	2 ch(Q5,Q6)	yes	yes	2 Routes(99KHZ)
ELC-18DC-DA-R	available	DC12-24V	8analog/digital+4digital	6 relays (10A)	no	yes	yes	2 Routes(99KHZ)
ELC-18DC-DA-TP	available	DC12-24V	8analog/digital+4digital	6 transistor (0.3A)	2 ch(Q5,Q6)	yes	yes	2 Routes(99KHZ)

Economic ELC-18CPU UNITS								
	Expansion	Supply voltage	Inputs	Outputs	PWM	HMI	RTC	High-speed count
ELC-18AC-R-E	No	AC110~AC240V	12 digital	6 relays (10A)	no	yes	yes	2 Routes(99KHZ)
ELC-18DC-D-R-E	No	DC12-24V	12 digital	6 relays (10A)	no	yes	yes	2 Routes(99KHZ)
ELC-18DC-D-TP-E	No	DC12-24V	12 digital	6 transistor (0.3A)	no	yes	yes	2 Routes(99KHZ)
ELC-18DC-DA-R-E	No	DC12-24V	8analog/digital+4digital	6 relays (10A)	no	yes	yes	2 Routes(99KHZ)
ELC-18DC-DA-TP-E	No	DC12-24V	8analog/digital+4digital	6 transistor (0.3A)	no	yes	yes	2 Routes(99KHZ)

Expansion Modules			
	Supply voltage	Inputs	Outputs
ELC-E-16AC-R	AC110~AC240V	8 digital	4 relays (10A) +4 relays(3A)
ELC-E-16DC-D-R	DC12-24V	8digital	4 relays (10A) +4 relays(3A)
ELC-E-16DC-DA-R	DC12-24V	6digital+2analog/digital	4 relays (10A) +4 relays(3A)

Accessories	
ELC-RS232	RS232 communication module /download cable between PC and xLogic CPU units
ELC-USB	USB communication module /download cable between PC and xLogic CPU units
ELC-Ethernet	Ethernet module connecting to ELC-18 CPU units
ELC-SMS-D-R	SMS module can be connected to ELC-18 CPU units.(DC 24V power supply,6 digital inputs,4 relay outputs)



Structure

1. ELC-18 Series Main Module

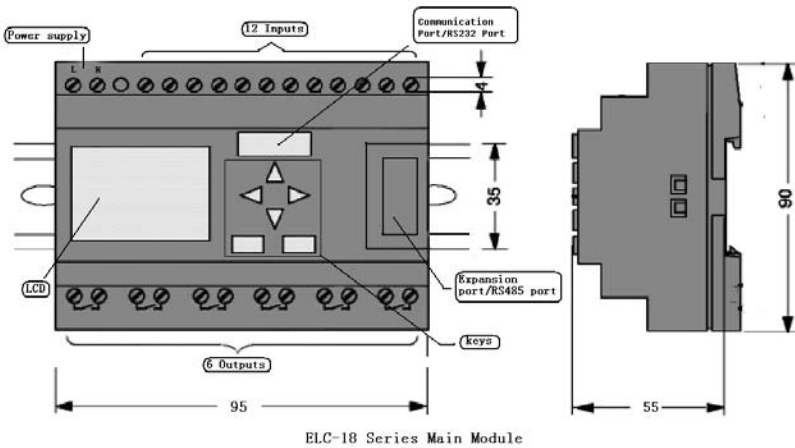

2. ELC-12 Series Main Module

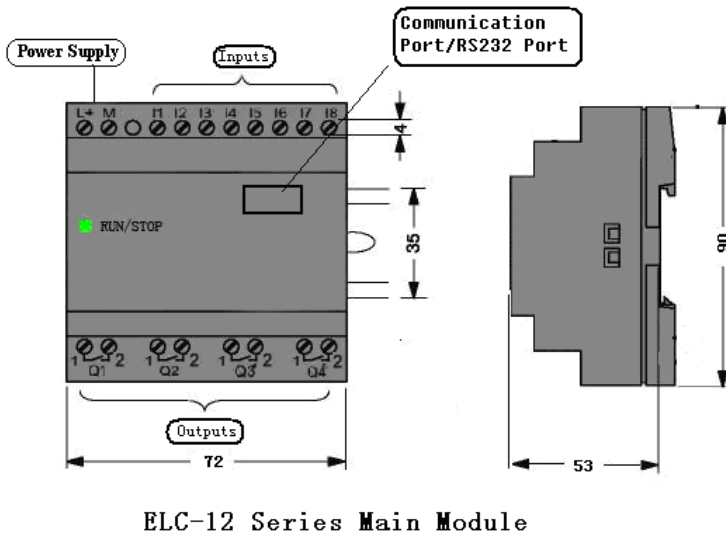

3. ELC-E Series Expansion Module

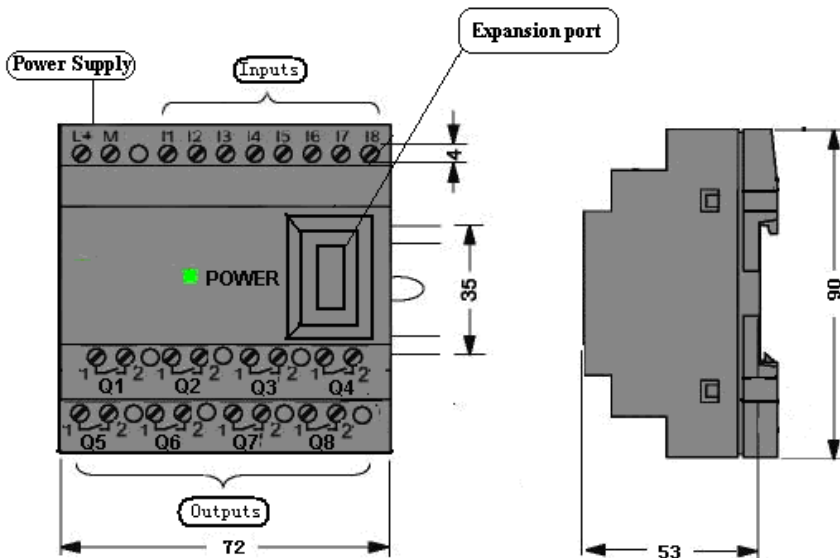

ELC-E Series Expansion Module

2. Installing/removing xLogic

Dimensions

The xLogic installation dimensions are compliant with DIN 43880. xLogic can be snap-mounted to 35 mm DIN rails to EN 50022 or on the wall.

xLogic width:

- ELC-12 Series Main Module has a width of 72mm.
- ELC-18 Series Main Module has a width of 95mm.
- ELC-E expansion modules have a width of 72mm .



Note

The figure below shows you an example of the installation and removal of an ELC-12AC main module. The measures shown apply to all other ELC-12 Series versions and ELC-18 Series versions and expansion modules.

Warning



Always switch off power before you "remove" and "insert" an expansion module.

2.1 DIN rail mounting

1. Hook the xLogic Basic module onto the rail.
2. Push down the lower end to snap it on. The mounting interlock at the rear must engage.

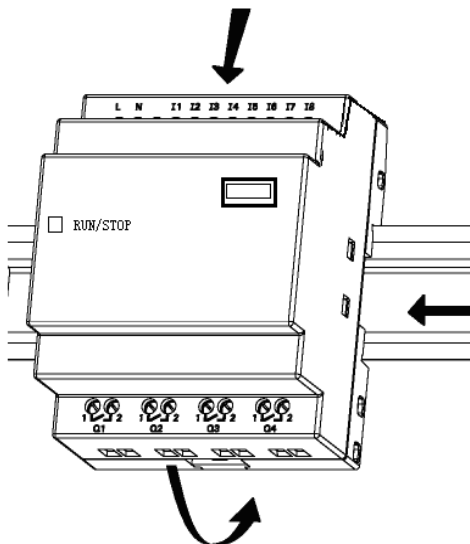

2.2 Wiring the xLogic

Wire the xLogic using a screwdriver with a 3-mm blade.

You do not need wire ferrules for the terminals. You can use conductors with cross-sections of up to the following thicknesses:

- 1 x 2.5 mm²
- 2 x 1.5 mm² for each second terminal chamber
- Tightening torque: 0.4.. .0.5 N/m or 3. ..4 lbs/in

Note

Always cover the terminals after you have completed the installation. To protect xLogic adequately from impermissible contact to live parts, local standards must be complied with.

2.2.1 Connecting the power supply

The ELC-18AC and ELC-12AC versions of ELC are suitable for operation with rated voltages of 110 V AC and 240 V AC. The ELC-18DC and ELC-12DC versions can be operated with a 12 or 24 VDC power supply. For information on permissible voltage tolerances, line frequencies and power consumption, refer to the installation instructions in the Product Information supplied with your device and to the technical data in Appendix A.

Note

A power failure may cause an additional edge triggering signal. Data of the last uninterrupted cycle are stored in xLogic.



To connect xLogic to the power supply:

With DC power supply

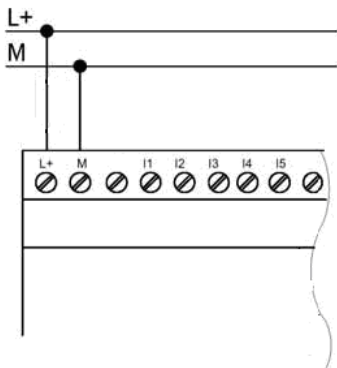

With AC power supply

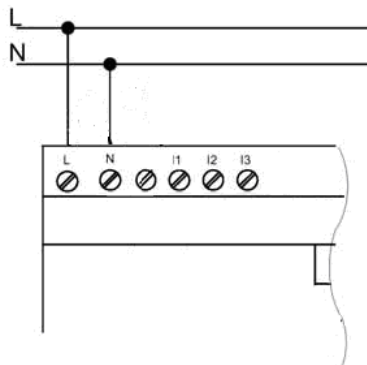

2.2.2. Connecting xLogic inputs

1. Requirements

At the inputs you connect sensor elements such as: momentary switches, switches, light barriers, daylight control switches etc.

	ELC-18AC ELC-12AC ELC-E-16AC	ELC-18DC ELC-12DC ELC-E-16DC
Signal status 0 Input current	<40VAC <0.24mA	<3VDC <1.5mA
Signal status 1 Input current	>85 VAC Typical 0.24mA	>8VDC Typical 3mA
Analogue input	NO	AI1-AI8(0-10V DC)



Note:

1. For ELC-18DC Series and ELC-12DC Series versions. That can receive analog input. They can be set to analog input or switching input as either may be used in the program. They will be recognized as analog inputs when the input terminal is connected with an analog function block, and they will be recognized as switching inputs when the input terminal is not connected with an analog function block.
2. The analog inputs require DC 0V ~ +10V voltage signals. These are divided equally in 0.02V increments. In programming, all the block parameters related to the analog inputs are based on the minimum increment of 0.02V.
3. They can be recognized as switching input when the input voltage is more than 10.0V and cannot be recognized as an analog input.
4. For the switching input off, when the switch status changes from 0 to 1, the time of Status 1 must be greater than 50ms, and when the switch status changes from 1 to 0, the time of Status 0 also must be greater than 50ms.

2. Connecting xLogic is shown as in the following figures:

*** ELC-18DC and ELC-12DC Series inputs**

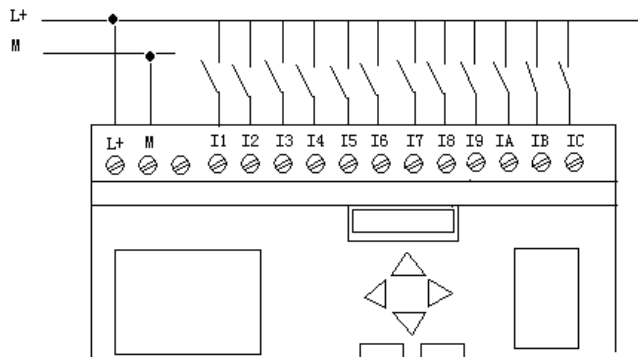

*** ELC-18AC Series and ELC-12AC inputs**



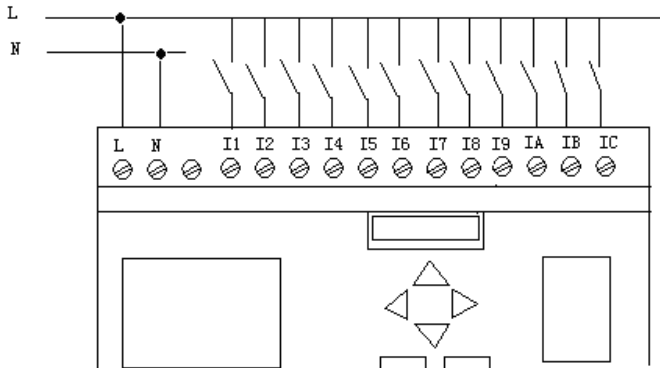

*** ELC-Analog Inputs**

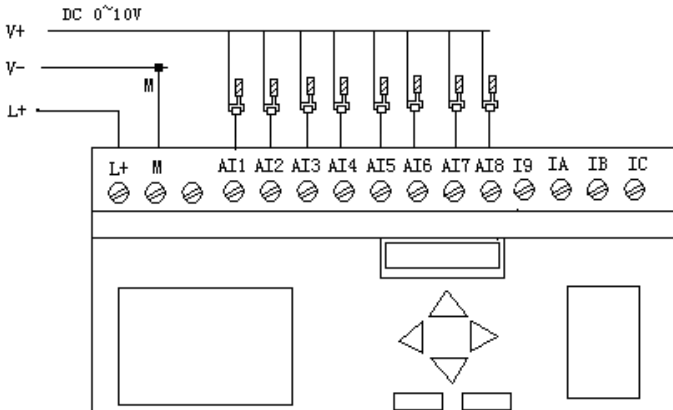

ELC-Analog Series Inputs



2.2.3 Connecting xLogic Outputs

1. Requirement for the relay output

Various loads such as lamp, fluorescent tube, motor, contact, etc., can be connected to the outputs of xLogic. The maximum ON output current that can be supplied by xLogic, is 10A for the resistance load and 2A for the inductive load. The connection is in accordance with the following figure:

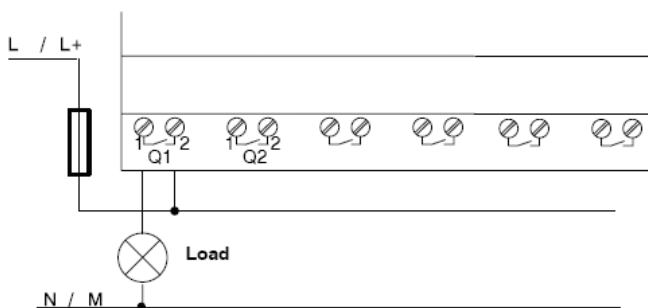

Relay Output

2. Requirement for the electronic transistor output:

The load connected to xLogic must have the following characteristics:

- * The maximum switch current cannot exceed 2A.
- * When the switch is ON (Q=1), the maximum current is 2A.



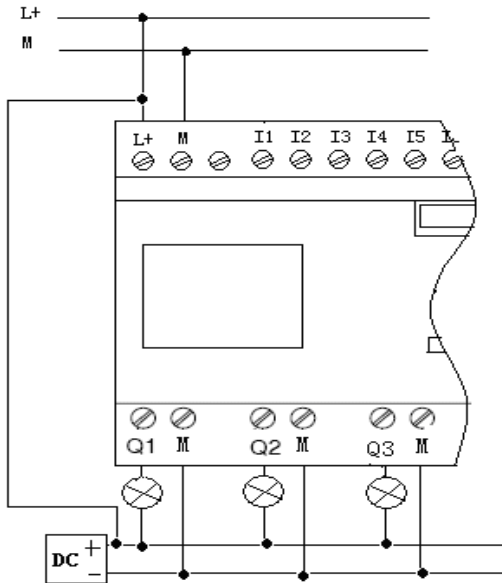

Transistor Output (PNP)

Notes (PNP):

- * The load connecting voltage must be $\leq 80\text{VDC}$ and it must be DC.
- * The "+" terminal of the output wiring must be connected with the DC positive voltage, and it must be connected with the "L+" terminal of the xLogic power a load must be connected with the "-" terminal of the DC positive voltage.



3 Programming xLogic

ELC series adopts the programming methods by the use of function blocks. A total of 8 general function blocks, 29 special function blocks, and 6 input & output function blocks are configured. And each block can achieve a specific control function independently, e.g. TOND, TOFD, SBPL, TBPL, SCHED, etc. As several blocks are linked up in a specific way, relatively complicated control functions can be performed. Programming with function blocks is simpler and better appreciated than the conventional PLC instruction programming.

The following types of operator for xLogic function blocks are available for options:

3.1 General Input & Output functions

3.1.1 Inputs

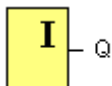

Input blocks represent the input terminals of xLogic. Up to 260 digital inputs are available to you.

In your block configuration, you can assign an input block a new input terminal, if this terminal is not already used in the circuit program.

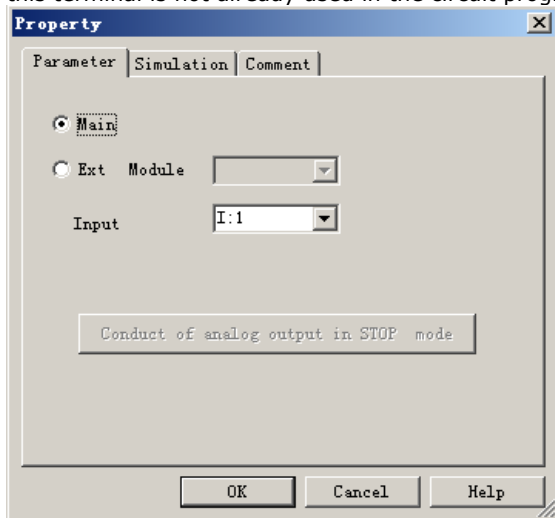

3.1.2 Cursor keys

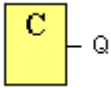

Up to four cursor keys are available to you. Cursor keys are programmed for the circuit program in the same ways as other inputs. Cursor keys can save switches and inputs, and allow operator control of the circuit program.

3.1.3 Outputs

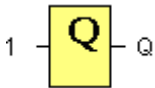

Output blocks represent the output terminals of xLogic. You can use up to 254 outputs. In your block configuration, you can assign an output block a new terminal, provided this terminal is not already used in your circuit program.

The output always carries the signal of the previous program cycle. This value does not change within the current program cycle.

3.1.4 Permanent logical levels HI and LO

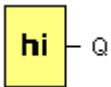

Set the block input to logical **hi** (hi = high) to set it permanently to logical '1' or 'H' state.

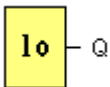

Set the block input to logical **lo** (lo = low) to set it permanently to logical '0' or 'L' state.

3.1.5 Shift register bits

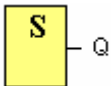

xLogic provides the shift register bits S1 to S8, which are assigned the read-only attribute in the circuit program. The content of shift register bits can only be modified by means of the Shift register special function



3.1.6 Analog inputs



You can use up to 88 analog inputs. In your block configuration, you can assign a new input terminal to an input block, provided this terminal is not already used in the circuit program.

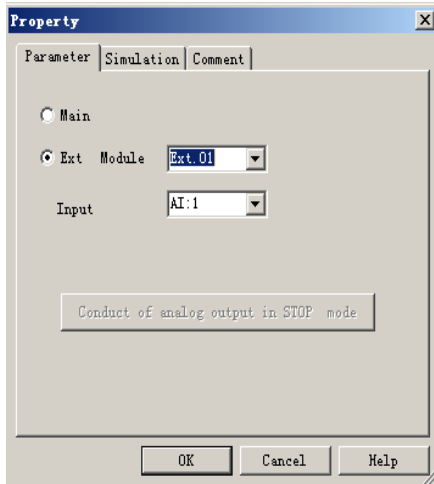

For help on analog block parameter, refer to Information on analog value processing.

3.2 Basic functions list – GF

Basic functions represent simple logical elements of Boolean algebra.

You can invert the inputs of individual basic functions, i.e. the circuit program inverts a logical "1" at a relevant input to a logical "0"; if "0" is set at the input, the program sets a logical "1".

The GF list contains the basic function blocks you can use for your circuit program.

The following basic functions are available:



3.2.1 AND

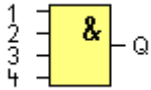

The output of an AND function is only 1 if **all** inputs are 1, i.e. when they are closed.

A block input that is not used (x) is assigned: $x = 1$.

Logic table of the AND block:

Input 1	Input 2	Input 3	Input 4	Output
0	0	0	0	0
0	0	0	1	0
0	0	1	0	0
0	0	1	1	0
0	1	0	0	0
0	1	0	1	0
0	1	1	0	0
0	1	1	1	0
1	0	0	0	0
1	0	0	1	0
1	0	1	0	0
1	0	1	1	0
1	1	0	0	0
1	1	0	1	0
1	1	1	0	0
1	1	1	1	1



3.2.2 AND with edge evaluation

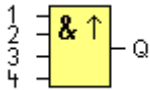

The output of an AND with edge evaluation is only 1 if **all** inputs are 1 and **at least one** input was 0 during the last cycle.

The output is set to 1 for the duration of one cycle and must be reset to 0 for the duration of the next cycle before it can be set to 1 again.

A block input that is not used (x) is assigned: $x = 1$.

Timing diagram of an AND with edge evaluation

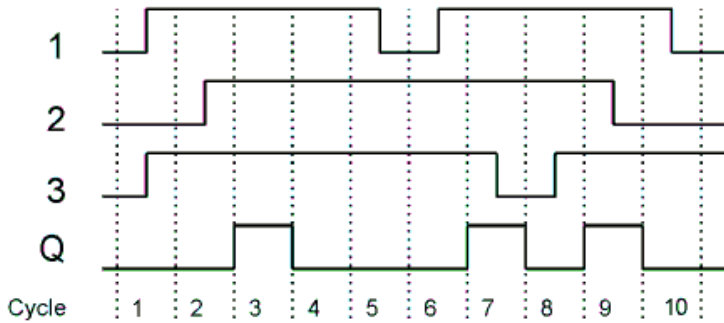

3.2.3 NAND



The output of an NAND function is only 0 if **all** inputs are 1, i.e. when they are closed.

A block input that is not used (x) is assigned: $x = 1$.

Logic table of the NAND block:



Input 1	Input 2	Input 3	Input 4	Output
0	0	0	0	1
0	0	0	1	1
0	0	1	0	1
0	0	1	1	1
0	1	0	0	1
0	1	0	1	1
0	1	1	0	1
0	1	1	1	1
1	0	0	0	1
1	0	0	1	1
1	0	1	0	1
1	0	1	1	1
1	1	0	0	1
1	1	0	1	1
1	1	1	0	1
1	1	1	1	0

3.2.4 NAND with edge evaluation

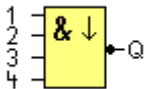

The output of a NAND with edge evaluation is only 1 **at least one** input is 0 and **all** inputs were 1 during the last cycle.

The output is set to 1 for the duration of one cycle and must be reset to 0 at least for the duration of the next cycle before it can be set to 1 again.

A block input that is not used (x) is assigned: $x = 1$.

Timing diagram of a NAND with edge evaluation



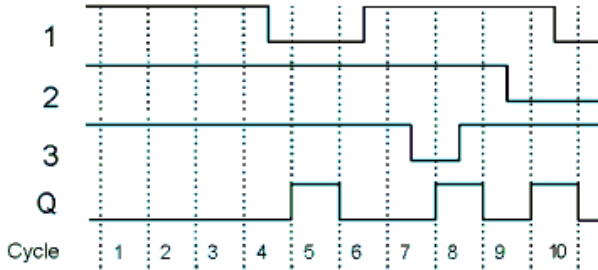

3.2.5 OR

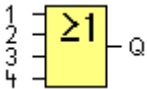

The output of an OR is 1 if **at least one** input is 1 hat, i.e. when it is closed.

A block input that is not used (x) is assigned: $x = 0$.

Logic table of the OR function:

Input 1	Input 2	Input 3	Input 4	Output
0	0	0	0	0
0	0	0	1	1
0	0	1	0	1
0	0	1	1	1
0	1	0	0	1
0	1	0	1	1
0	1	1	0	1
0	1	1	1	1
1	0	0	0	1
1	0	0	1	1
1	0	1	0	1
1	0	1	1	1
1	1	0	0	1
1	1	0	1	1
1	1	1	0	1
1	1	1	1	1



3.2.6 NOR

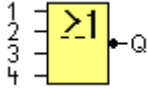

The output of a NOR (NOT OR) is only 1 if **all** inputs are 0 hat, i.e. when they are open. When one of the inputs is switched on (logical 1 state), the output is switched off.

A block input that is not used (x) is assigned: $x = 0$.

Logic table of the NOR function:

Input 1	Input 2	Input 3	Input 4	Output
0	0	0	0	1
0	0	0	1	0
0	0	1	0	0
0	0	1	1	0
0	1	0	0	0
0	1	0	1	0
0	1	1	0	0
0	1	1	1	0
1	0	0	0	0
1	0	0	1	0
1	0	1	0	0
1	0	1	1	0
1	1	0	0	0
1	1	0	1	0
1	1	1	0	0
1	1	1	1	0
1	1	1	1	0



3.2.7 XOR

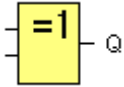

The XOR (exclusive OR) output is 1 if the signal status of the inputs is **different**.

A block input that is not used (x) is assigned: $x = 0$.

Logic table of the XOR function:

Input 1	Input 2	Output
0	0	0
0	1	1
1	0	1
1	1	0

3.2.8 NOT

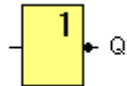

The output is 1 if the input is 0. The NOT block inverts the input status.

Advantage of the NOT, for example: xLogic no longer requires break contacts. You simply use a make contact and convert it into a break contact with the help of the NOT function.

Logic table of the NOT function:

Input 1	Output
0	1
1	0

3.3 Basics on special functions

Because of their different input designation, you can see right away that there is a difference between the special functions and basic functions. SFs contain timer functions, retentive functions and various parameter assignment options, which allow you to adapt the circuit program to suit your own requirements.

This section provides you with a brief overview of input designations and with some



particular background information on SFs. The SFs in particular are described in Chapter 4

3.3.1 Designation of the inputs

Logical inputs

Here, you will find the description of the connectors you can use to create a logical link to other blocks or to the inputs of the xLogic unit.

S (Set):

A signal at input S sets the output to logical "1".

R (Reset):

The reset input R takes priority over all other inputs and resets the outputs.

Trg (Trigger):

This input is used to trigger the start of a function.

Cnt (Count):

This input is used for counting pulses.

Fre (Frequency):

Frequency signals to be evaluated are applied to this input.

Dir (Direction):

This input determines the direction of count.

En (Enable):

This input enables a block function. When this input is "0", other signals to the block will be ignored.

Inv (Invert):

A signal at this input inverts the output signal of the block.

Ral (Reset all):

All internal values are reset.

Parameter inputs

At some of the inputs you do not apply any signals. You configure the relevant block values instead. Examples:

- **Par (Parameter):**

This input will not be connected. Here, you set the relevant block parameters (times, on/off thresholds etc.).

- **No (Cam):**

This input will not be connected. Here, you configure the time patterns.



● **P (Priority):**

This is an open input. Here, you define priorities and specify whether a message is to be acknowledged in RUN.

3.3.2 Time response

Parameter T

At some of the SFs it is possible to configure a time value T. When you preset this time, note that your input values are based on the timebase set:

Timebase	-- : --
s (seconds)	seconds : $\frac{1}{100}$ seconds
m (minutes)	minutes : seconds
h (hours)	hours : minutes

Accuracy of T

Because of slight tolerances in the characteristics of electronic components, the set time T may deviate. The xLogic has a maximum tolerance of $\pm 0.02\%$.

When 0.02 % of the time T is smaller than 0.02 seconds, the maximum deviation is 0.02 seconds.

Example: The maximum tolerance per hour (3600 seconds) is $\pm 0.02\%$, which is proportional to ± 0.72 seconds. The maximum tolerance per minute (60 seconds) is ± 0.02 seconds.

Accuracy of the timer (weekly/yearly timer)

To prevent timing inaccuracy of the real-time clock in C versions caused by this deviation, the timer value is continuously compared with a high-precision time-base and corrected. The resultant maximum timing in accuracy is ± 5 s/day.

3.3.3 Backup of the real-time clock

Because the internal real-time clock of an xLogic is backed up, it continues operation after a power failure. The ambient temperature influences the backup time. At an ambient temperature of 25°C, the



typical backup time of ELC-18 is 10 hours and ELC-12 is 72 hours. If there is a power outage of an ELC-18 for more than 10 hours, the internal clock responds, dependent on the equipment series.

3.3.4 Retentivity

The switching states and counter values of SFs can be set retentive. This means that current data are retained after a power failure, and that the block resumes operation at the break point. The timer is not reset, but resumes operation until the time-to-go has expired, for example, to enable this response, however, the relevant functions must be set retentive.

3.3.5 Parameter protection

In the parameter protection settings, you can determine whether the parameters can be displayed and edited in xLogic parameter modify mode or not.

3.3.6 Calculating the gain and offset of analog values

A sensor is connected to the analog input and converts a process variable into an electrical signal. This value of signal lies within the typical range of this sensor. xLogic always converts the electrical signals at the analog input into digital values from 0 to 1000. A voltage of 0 to 10 V at input AI is transformed internally into range of values from 0 to 1000. An input voltage exceeding 10 V is shown as internal value 1000.

Because you can not always process the range of values from 0 to 1000 as predetermined by xLogic, you can multiply the digital values by a gain factor and then shift the zero of the range of values (offset). This allows you to output an analog value to the xLogic display, which is proportional to the actual process variable.

Parameter	Minimum	Maximum
Input voltage (in V)	0	≥ 10
Internal value	0	1000
Gain	-10.00	+10.00
Offset	-10000	+10000



Mathematical rule

Actual value Ax =

(internal value at input Ax·gain) + offset

Gain and offset calculation

The gain and offset is calculated based on the relevant high and low values of the function.

Example 1:

The available thermocouples have the following technical data: -30 to +70°C, 0 to 10 V DC (i.e. 0 to 1000 in xLogic).

Actual value = (internal value ·gain) + offset, thus

$$-30 = (0 \cdot A) + B, \text{ i.e. offset } B = -30$$

$$+70 = (1000 \cdot A) - 30, \text{ i.e. gain } A = 0.1$$

Example 2:

A pressure sensor converts a pressure of 1000 mbar into a voltage of 0 V, and a pressure of 5000 mbar into a voltage of 10 V.

Actual value = (internal value · gain) + offset, thus

$$1000 = (0 \cdot A) + B, \text{ i.e. offset } B = 1000$$

$$5000 = (1000 \cdot A) + 1000, \text{ i.e. gain } A = 4$$

Example of analog values

Process variable	Voltage (V)	Internal value	Gain	Offset	Value shown (Ax)
-30° C	0	0	0.1	-30	-30
0° C	3	300	0.1	-30	0
+70° C	10	1000	0.1	-30	70
1000 mbar	0	0	4	1000	1000
3700 mbar	6.75	675	4	1000	3700
5000 mbar	10	1000	4	1000	5000
	0	0	0.01	0	0
	5	500	0.01	0	5
	10	1000	0.01	0	10
	0	0	1	0	0
	5	500	1	0	500
	10	1000	1	0	1000
	0	0	10	0	0
	5	500	10	0	5000
	10	1000	10	0	10000
	0	0	0.01	5	5
	5	500	0.01	5	10
	10	1000	0.01	5	15



	0	0	1	500	500
	5	500	1	500	1000
	10	1000	1	500	1500
	0	0	1	-200	-200
	5	500	1	-200	300
	10	1000	1	-200	800
	0	0	10	-10000	-10000
	10	1000	10	-10000	0
	0.02	2	0.01	0	0
	0.02	2	0.1	0	0
	0.02	2	1	0	2
	0.02	2	10	0	20

3.4 Special functions list – SF

When you create your circuit program in xLogicsoft, you find the special function blocks in the SF list.

You can invert the inputs of SFs individually, i.e. the circuit program converts a logical "1" at the input into a logical "0"; a logical "0" it converts into a logical "1". The table also specifies whether the relevant function can be set retentivity (Rem). The following SFs are available:

3.4.1 On-delay

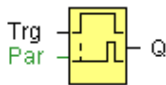

Short description

The output is not switched on until a configured delay time has expired.

Connection	Description
Trg input	The on delay time is triggered via the Trg (Trigger) input
Parameter	T represents the on delay time after which the output is switched on (output signal transition 0 to 1). Retentivity on = the status is retentive in memory.
Output Q	Q switches on after a specified time T has expired, provided Trg is still set.



Parameter

You select the required function via the block number. Time-base can be adjusted.

The value of " T " can be set/modified in parameter mode. For information about how to modify, refer to chapter 4.2.2 please.

For information on the validity and accuracy of the time base, refer to the xLogic time-base list as follows:

Valid ranges of the time-base, if T = parameter

Time-base	Max. value	Min. resolution	Accuracy
s (seconds)	99:99	10 ms	± 10 ms
m (minutes)	99:59	1s	± 1 s
h (hours)	99:59	1 min	± 1 min

Timing diagram

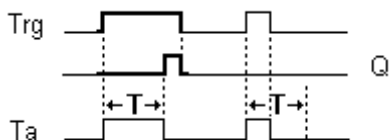

Description of the function

The time T_a (the current time in xLogic) is triggered with the 0 to 1 transition at input Trg.

If the status at input Trg stays 1 at least for the duration of the configured time T, the output is set to 1 when this time has expired (the on signal of the output follows the on signal of the input with delay).

The time is reset if the status at input Trg changes to 0 again before the time T has expired.

The output is reset to 0 when input Trg is 0.



3.4.2 Off-delay

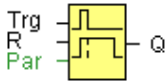

Short description

The output with off delay is not reset until a defined time has expired.

Connection	Description
Input Trg	Start the off delay time with a negative edge (1 to 0 transition) at input Trg (Trigger)
Input R	Reset the off delay time and set the output to 0 via the R (Reset) input. Reset has priority over Trg
Parameter	T : The output is switched off on expiration of the delay time T (output signal transition 1 to 0). Retentivity on = the status is retentive in memory.
Output Q	Q is switched on for the duration of the time T after a trigger at input Trg.

Parameter

The value of " T " can be set/modified in parameter mode. For information about how to modify, refer to chapter 4.2.2 please.

For information on the validity and accuracy of the time base, refer to 3.4.1

Timing diagram

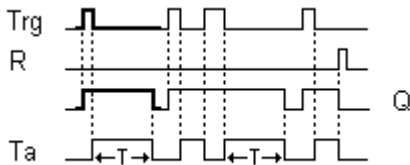

Description of the function

Output Q is set to 1 momentarily with a 0 to 1 transition at input Trg.

At the 1 to 0 transition at input Trg, xLogic retriggers the current time T, and the output remains set. The output Q is reset to 0 when T_a reaches the value specified in T ($T_a=T$) (off delay).



A one-shot at input Trg retriggers the time T_a .

You can reset the time T_a and the output via the input R (Reset) before the time T_a has expired.

3.4.3 On-/Off-delay

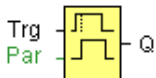

Short description

The on/off delay function is used to set an output after a configured on delay time and then reset it again upon expiration of a second configured time.

Connection	Description
Input Trg	You trigger the on delay with a positive edge (0 to 1 transition) at input Trg (Trigger). You trigger the off delay with a negative edge (1 to 0 transition).
Parameter	T_H is the on delay time for the output (output signal transition 0 to 1). T_L is the off delay time for the output (output signal transition 1 to 0). Retentivity on = the status is retentive in memory.
Output Q	Q is switched on upon expiration of a configured time T_H if Trg is still set. It is switched off again upon expiration of the time T_L and if Trg has not been set again.

Parameter

The value of " T_H ", " T_L " can be set/modified in parameter mode. For information about how to modify ,refer to chapter 4.2.2 please.

For information on the validity and accuracy of the time base, refer to 3.4.1

Timing diagram



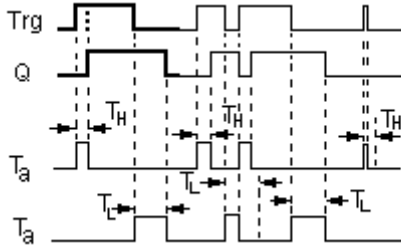

Description of the function

The time T_H is triggered with a 0 to 1 transition at input Trg.

If the status at input Trg is 1 at least for the duration of the configured time T_{Hr} , the output is set to logical 1 upon expiration of this time (output is on delayed to the input signal).

The time T_H is reset if the status at input Trg is reset to 0 before this time has expired.

The time T_L is triggered with the 1 to 0 transition at the output.

If the status at input Trg remains 0 at least for the duration of a configured time T_{Lr} , the output is reset to 0 upon expiration of this time (output is off delayed to the input signal).

The time T_L is reset if the status at input Trg is returns to 1 before this time has expired.



3.4.4 Retentive on-delay

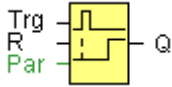

Short description

A one-shot at the input triggers a configurable time. The output is set upon expiration of this time.

Connection	Description
Input Trg	Trigger the on delay time via the Trg (Trigger) input.
Input R	Reset the time on delay time and reset the output to 0 via input R (Reset). Reset takes priority over Trg.
Parameter	T is the on delay time for the output (output signal transition 0 to 1). Retentivity on = the status is retentive in memory.
Output Q	Q is switched on upon expiration of the time T.

Parameter

The value of " T " can be set/modified in parameter mode. For information about how to modify, refer to chapter 4.2.2 please.

Timing diagram

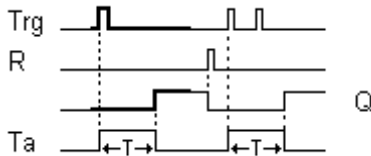

Description of the function



The current time T_a is triggered with a 0 to 1 signal transition at input Trg. Output Q is set to 1 when T_a reaches the time T. A further pulse at input Trg does not affect T_a .

The output and the time T_a are only reset to 0 with a 1 signal at input R.

If retentivity is not set, output Q and the expired time are reset after a power failure.

3.4.5 Wiping relay (pulse output)

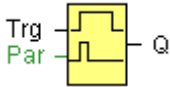

Short description

An input signal generates an output signal of a configurable length.

Connection	Description
Input Trg	You trigger the time for the wiping relay with a signal at input Trg (Trigger)
Parameter	TL represents the time after which the output is reset (output signal transition 1 to 0). Retentivity set (on) = the status is retentive in memory.
Output Q	A pulse at Trg sets Q. The output stays set until the time T has expired and if Trg = 1 for the duration of this time. A 1 to 0 transition at Trg prior to the expiration of T also resets the output to 0.

Parameter

The value of " T L " can be set/modified in parameter mode. For information about how to modify, refer to chapter 4.2.2 please.

Timing diagram

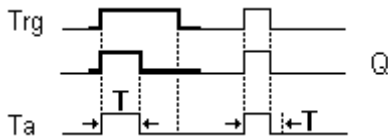

Description of the function



With the input signal Trg = 1, output Q is set to 1. The signal also triggers the time Ta, while the output remains set.

When Ta reaches the value defined at T (Ta=T), the output Q is reset to 0 state (pulse output).

If the signal at input Trg changes from 1 to 0 before this time has expired, the output is immediately reset from 1 to 0.

3.4.6 Edge triggered wiping relay

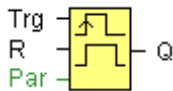

Short description

An input pulse generates a preset number of output pulses with a defined pulse/pause ratio (retriggerable), after a configured delay time has expired.

Connection	Description
Input Trg	You trigger the times for the Edge-triggered wiping relay with a signal at input Trg (Trigger).
Input R	The output and the current time Ta are reset to 0 with a signal at input R.
Parameter	TL, TH: The interpulse period T_L and the pulse period T_H are adjustable. N determines the number of pulse/pause cycles T_L / T_H : Value range: 1...9. Retentivity set (on) = the status is retentive in memory.
Output Q	Output Q is set when the time T_L has expired and is reset when T_H has expired.

Parameter

The value of " T_H ", " T_L " can be set/modified in parameter mode. For information about how to modify ,refer to chapter 4.2.2 please.

Timing diagram



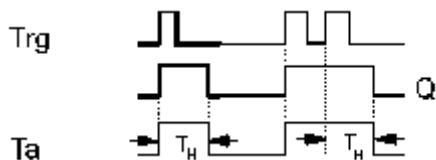

$T_L = 0; N = 1$

Description of the function

With the change at input Trg to 1, the time T_L (time low) is triggered. After the time T_L has expired, output Q is set to 1 for the duration of the time T_H (time high).

If input Trg is retriggered prior to the expiration of the preset time ($T_L + T_H$), the time T_a is reset and the pulse/pause period is restarted.

3.4.7 Asynchronous pulse generator

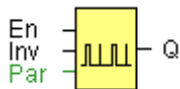

Description of function

The pulse shape at the output can be modified via a configurable pulse/pause ratio.

Connection	Description
Input En	You enable/disable the asynchronous pulse generator with the signal at input En.
Input Inv	The Inv input can be used to invert the output signal of the active asynchronous pulse generator..
Parameter	TL,TH: You can customize the pulse (TL)/ pause (TH) ratio. Retentivity set (on) = the status is retentive in memory.
Output Q	Q is toggled on and off cyclically with the pulse times T_H and T_L .

Parameter



The value of " TH ", " TL " can be set/modified in parameter mode. For information about how to modify ,refer to chapter 4.2.2 please.

Timing diagram



Description of the function

You can set the pulse/pause ratio at the TH (Time High) and TL (Time Low) parameters.

The INV input can be used to invert the output signal. The input block INV only inverts the output signal if the block is enabled via EN.

3.4.8 Random generator

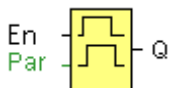

Short description

The output of a random generator is toggled within a configurable time.

Connection	Description
Input En	The positive edge (0 to 1 transition) at the enable input En (Enable) triggers the on delay for the random generator. The negative edge (1 to 0 transition) triggers the off delay for the random generator.
Parameter	TH: The on delay is determined at random and lies between 0 s and T_H . TL: The off delay is determined at random and lies between 0 s and T_L .
Output Q	Q is set on expiration of the on delay if En is still set. It is reset when the off delay time has expired and if En has not been set again.



Parameter

The value of " T_H ", " T_L " can be set/modified in parameter mode. For information about how to modify ,refer to chapter 4.2.2 please.

Timing diagram

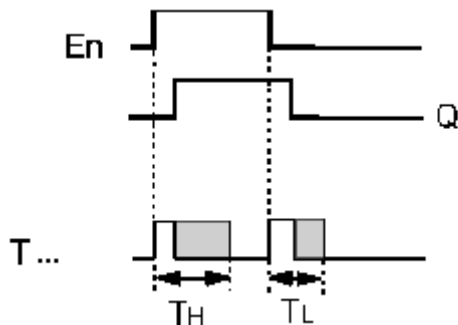

Description of the function

With the 0 to 1 transition at input En, a random time (on delay time) between 0 s and T_H is set and triggered. If the status at input En is 1 at least for the duration of the on delay, the output is set to 1 when this on delay time has expired.

The time is reset if the status at input En is reset to 0 before the on delay time has expired.

When input En is reset 0, a random time (off delay time) between 0 s and T_L is set and triggered.

If the status at input En is 0 at least for the duration of the off delay time, the output Q is reset to 0 when the off delay time has expired.

The time is reset if the status at input En returns to 1 before the on delay time has expired.

3.4.9 Stairway lighting switch

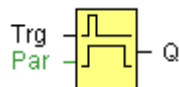

Short description



The edge of an input pulse triggers a configurable time. The output is reset when this time has expired. An off warning can be output prior to the expiration of this time.

Connection	Description
Input Trg	You trigger the time (off delay) for the stairway switch with a signal at input Trg (Trigger).
Parameter	<p>T: The output is reset (1 to 0 transition when the time T has expired.</p> <p>T_i determines the triggering time for the prewarning.</p> <p>T_{il} determines the length of the prewarning time.</p> <p>Retentivity set (on) = the status is retentive in memory.</p>
Output Q	Q is reset after the time T has expired. A warning signal can be output before this time has expired.

Parameter

The value of " T " can be set/modified in parameter mode. For information about how to modify, refer to chapter 4.2.2 please.

Timing diagram

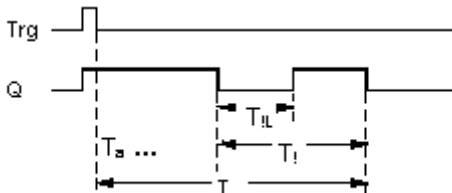

Changing the time base

You can change the prewarning time base and the period.

Time base T	Prewarning time	Prewarning period
Seconds	750 ms	50 ms
Minutes	15 s	1 s
Hours	15 min	1 min
* makes sense only for programs with a cycle time of < 25 ms		



Description of the function

Output Q is set to 1 with a 0 to 1 signal transition at input Trg. The 1 to 0 transition at input Trg triggers the current time and output Q remains set.

Output Q is reset to 0 when Ta reaches the time T. Before the off delay time ($T - T_I$) has expired, you can output a prewarning that resets Q for the duration of the off prewarning time T_{IL} .

Ta is retriggered (optional) at the next high/low transition at input Trg and if Ta is expiring.

3.4.10 Multiple function switch

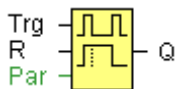

Short description

Switch with two different functions:

- Pulse switch with off delay
- Switch (continuous light)

Connection	Description
Input Trg	With a signal at input Trg (Trigger) you set output Q (continuous light), or reset Q with off delay. Output Q can be reset with a signal at the Trg input.
Input R	You set the current time Ta, and reset the output to 0, with a signal at input R.
Parameter	<p>T: The output is reset (1 to 0 transition) when the time T has expired.</p> <p>T_L determines the period during which the input must be set in order to enable the permanent light function.</p> <p>T_I determines the on delay for the prewarning time.</p> <p>T_{IL} determines the length of the prewarning time.</p> <p>Retentivity set (on) = the status is retentive in memory.</p>
Output Q	Output Q is set with a signal at input Trg, and it is reset again after a configured time has expired and depending on the pulse width at input Trg, or it is reset with another signal at input Trg.



Parameter

The value of " T ", " T_L " can be set/modified in parameter mode. For information about how to modify ,refer to chapter 4.2.2 please.

Timing diagram

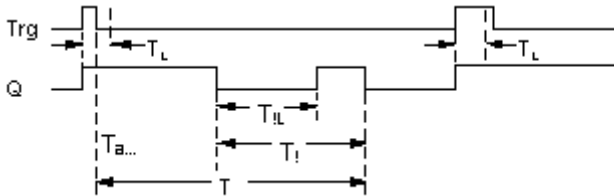

Description of the function

Output Q is set to 1 with a 0 to 1 signal transition at Trg.

If output Q = 0, and input Trg is set hi at least for the duration of T_L, the permanent lighting function is enabled and output Q is set accordingly.

The off delay time T is triggered when the status at input Trg changes to 0 before the time T_L has expired.

Output Q is reset when the T_a = T.

Before the off delay time (T - T_i) has expired, you can output an off prewarning that resets Q for the duration of the off prewarning time T_{iL}. A further signal at input Trg always resets T and output Q.

Caution

The time base for the T, T_i and T_{iL} must be identical.

3.4.11 Weekly timer

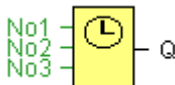

Caution

Your xLogic must be equipped with an internal real-time clock if you are going to use this SFB.



Short description

The output is controlled by means of a configurable on/off date. The function supports any combination of weekdays.

Connection	Description
Parameter	At the No1, No2, No3 (cam) parameters you set the on and off triggers for each cam of the weekly timer. The parameter units are the days and the time-of-day.
Output Q	Q is set when the configured cam is actuated.

Parameter

You can configure a time hysteresis for each individual cam in parameter mode. For information about how to modify, refer to chapter 4.2.2 please.

Timing diagram (three practical examples)

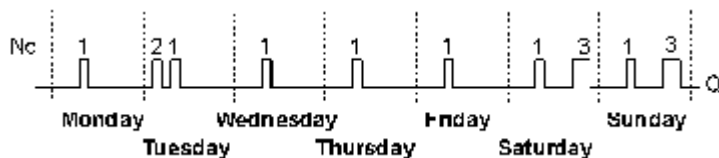

No1: Daily: 06:30 h to 08:00 h

No2: Tuesday: 03:10 h to 04:15 h

No3: Saturday and Sunday: 16:30 h to 23:10 h

Description of the function

Each weekly timer is equipped with three cams. You can configure a time hysteresis for each individual cam. At the cams you set the on and off hysteresis. The weekly timer sets the output at a certain time, provided it is not already set.

The output is reset at a certain time, provided it is not already reset. A conflict is generated in the weekly timer when the set on time and the set off time at another cam are identical. In this case, cam 3 takes priority over cam 2, while cam 2 takes priority over cam 1.

The switching status of the weekly timer is determined by the status at the No1, No2 and No3 cams.

On times

Any time between 00:00 h and 23:59 h.



Special characteristics to note when configuring

The block properties window offers a tab for each one of the three cams. Here you can set the weekly on times for the cams. Each tab offers you in addition an option of defining the on and off times for each cam in hour and minute units. Hence, the shortest switching cycle is one minute.

You can disable the on and off times individually, i.e. you can achieve switching cycles extending across more than one day, for example, by setting the on time for cam 1 to Monday 7:00 h and the off time of cam 2 to Wednesday 13:07 h, while disabling the on time for cam 2.

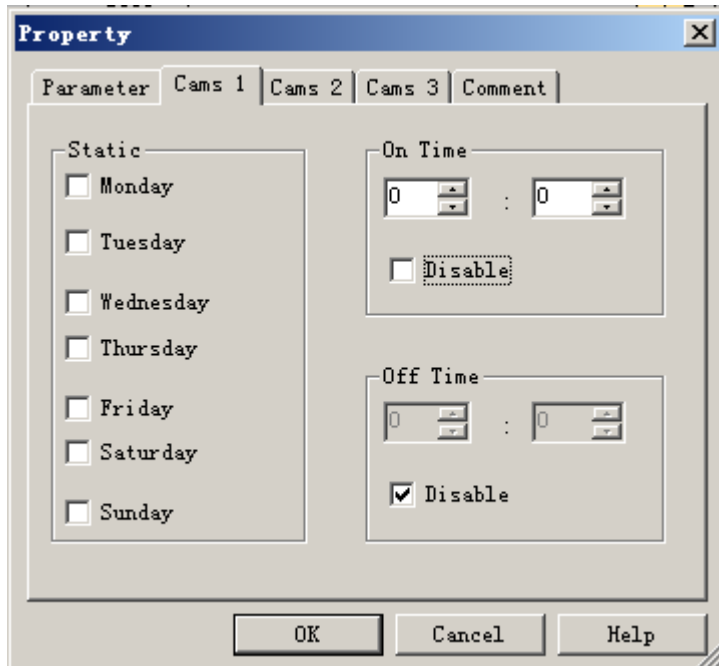

Backup of the real-time clock

The internal real-time clock of xLogic is buffered against power failure. The buffering time is influenced by the ambient temperature, and is typically 10 hours(ELC-18) or 72 hours(ELC-12) at an ambient temperature of 25°C.

3.4.12 Yearly timer





Caution

Your xLogic must be equipped with an internal real-time clock if you are going to use this SFB.

Short description

The output is controlled by means of a configurable on/off date

Connection	Description
Parameter	At the No (cam) parameter you set the on and off trigger for the cam of the yearly timer.
Output Q	Q is set on when the configured cam is switched on.

Parameter

The on and off trigger for the cam of the yearly timer can be set/modified in parameter mode and you can configure what you need. For information about how to modify, refer to chapter 4.2.2 please.

Timing diagram

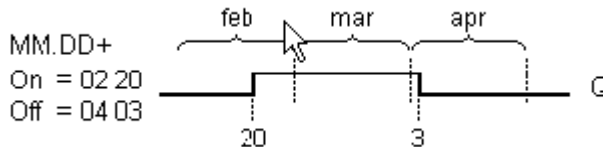

Description of the function

The yearly timer sets and resets the output at specific on and off times.

The off-date identifies the day on which the output is reset again. The first value defines the month, the second the day.

When you select the every month check box, the yearly clock switches on or off at a certain day of every month.

Backup of the real-time clock



The internal real-time clock of xLogic is buffered against power failure. The buffering time is influenced by the ambient temperature, and is typically 10 hours(ELC-18) or 72 hours(ELC-12) at an ambient temperature of 25°C.

Special characteristics to note when configuring

A click on the dialog box enables direct keyboard input of the month and day values. The values entered may not exceed the logical maximum of the relevant input boxes, otherwise xLogicsoft returns an error message.

The **calendar** icon offers you an easy way of setting the date. It opens a window where you can set the days and months by clicking the relevant buttons.

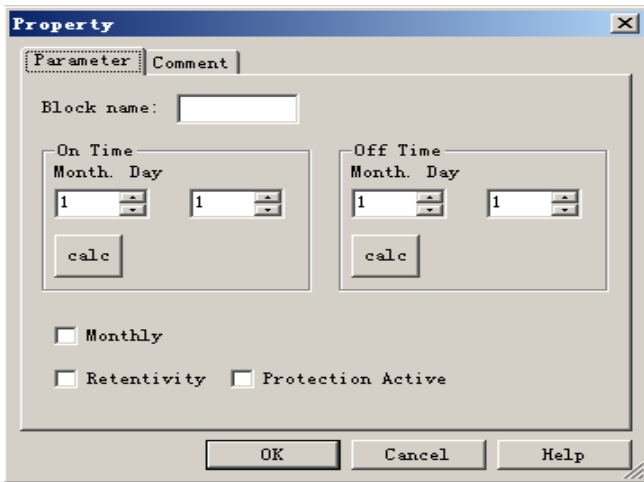

Sample configuration

The output of a xLogic is to be switched on annually, from 1st of March to 4th of April and from 7th of July to 19th of November. This requires two blocks for configuring the specific on times. The outputs are then linked via an OR block.

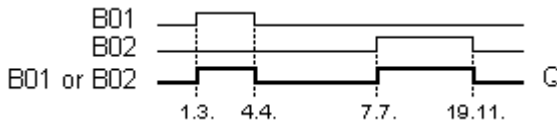

Place two yearly timer switch SFBs on your programming interface and configure the blocks as specified.



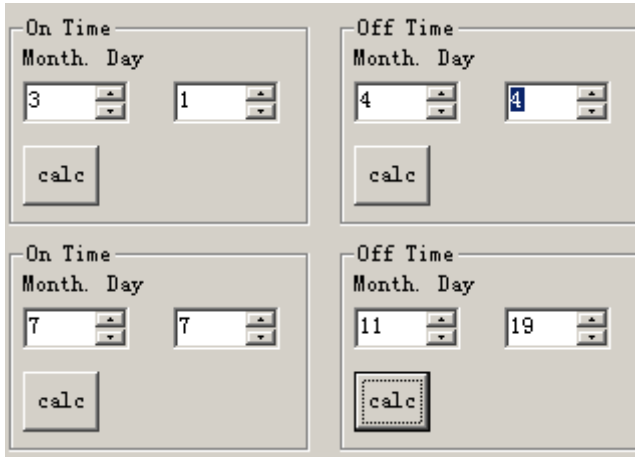

Create a logical link of the blocks via a standard OR block. The OR output is 1 if at least one of the yearly timer switches is set.

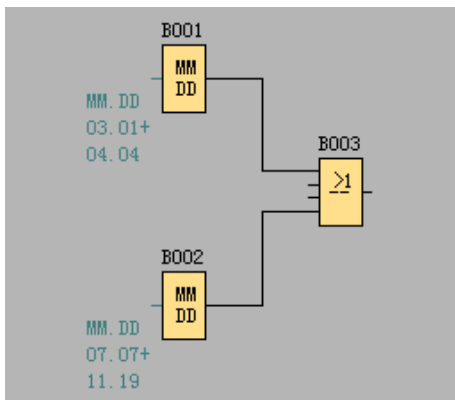

3.4.13 Up/Down counter

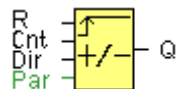

Short description

An input pulse increments or decrements an internal value, depending on the parameter setting. The output is set or reset when a configured threshold is reached. The direction of count can be changed with a signal at input Dir.

Connection	Description
------------	-------------



Input R	You reset the output and the internal counter value to zero with a signal at input R (Reset).
Input Cnt	This function counts the 0 to 1 transitions at input Cnt. It does not count 1 to 0 transitions. Use <ul style="list-style-type: none"> • The inputs I8 (ELC-12) or IB/IC(ELC-18) for high-frequency counts max. 99 kHz. • Any other input or circuit element for low-frequency counts (typical 4 Hz).
Input Dir	Input Dir (Direction) determines the direction of count: Dir = 0: Up Dir = 1: Down
Parameter	On: On threshold Value range: 0...999999 Off: Off threshold Value range: 0...999999 Retentivity set (on) = the status is retentive in memory.
Output Q	Q is set and reset according to the actual value at Cnt and the set thresholds.

Parameter

The value of " On ", " Off " and " Cnt " can be set/modified in parameter mode. For information about how to modify ,refer to chapter 4.2.2 please.

Timing diagram

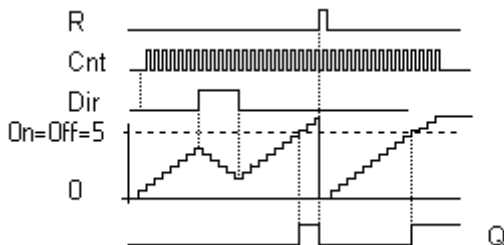

Description of the function

The function increments (Dir = 0) or decrements (Dir = 1) the internal counter by one count with every positive edge at input Cnt.

You can reset the internal counter value to '000000', with a signal at the reset input R. As long as R=1, the output is 0 and the pulses at input Cnt are not counted.



Output Q is set and reset according to the actual value at Cnt and the set thresholds. See the following rules for calculation.

Calculation rule

- If the on threshold \geq off threshold, then:
 $Q = 1$, if $Cnt \geq On$
 $Q = 0$, if $Cnt < Off$.
- If the on threshold $<$ off threshold, then:
 $Q = 1$, if $On \leq Cnt < Off$.

Caution

The function polls the limit value of the counter once in each cycle.

Thus, if the pulses at the fast inputs (ELC-12) or IB/IC(ELC-18) are faster than the scan cycle time, the SFB might not switch until the so specified limit has been exceeded.

Example: Up to 100 pulses per cycle can be counted; 900 pulses have been counted so far. On = 950; Off = 10000. The output is set in the next cycle, after the value has reached 1000.

The output would not be set at all if the value Off = 980

3.4.14 Hours counter

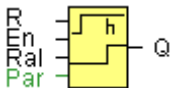

Short description

A configured time is triggered with a signal at the monitoring input. The output is set when this time has expired.

Connection	Description
Input R	A positive edge (0 to 1 transition) at input R resets output Q and sets a configured value MI at the counter for the duration of the time-to-go (MN).
Input En	En is the monitoring input. xLogic scans the on-time of this input.



Input Ral	<p>A positive edge at input Ral (Reset all) resets both the hours counter (OT) and the output, and sets the configured value MI at the counter to for the duration of the time-to-go (MN). That is,</p> <ul style="list-style-type: none"> • Output Q = 0, • The measured operating hours OT = 0, and • The time-to-go of the maintenance interval MN = MI.
Parameter	<p>MI: Maintenance interval to be specified in hour units Range of values: 0000...9999 h</p> <p>OT: Expired total operation time. An offset can be specified. Range of values: 00000...99999 h</p> <p>Q 0:</p> <ul style="list-style-type: none"> • When "R" is selected: Q = 1, if MN = 0; Q = 0, if R = 1 or Ral = 1 • When "R+En" is selected: Q = 1, if MN = 0; Q = 0, if R = 1 or Ral = 1 or En = 0.
Output Q	<p>The output is set when the time-to-go MN = 0. The output is reset:</p> <ul style="list-style-type: none"> • When "Q 0:R+En", if R = 1 or Ral = 1 or En = 0 • When "Q 0:R", if R = 1 or Ral = 1.

Timing diagram



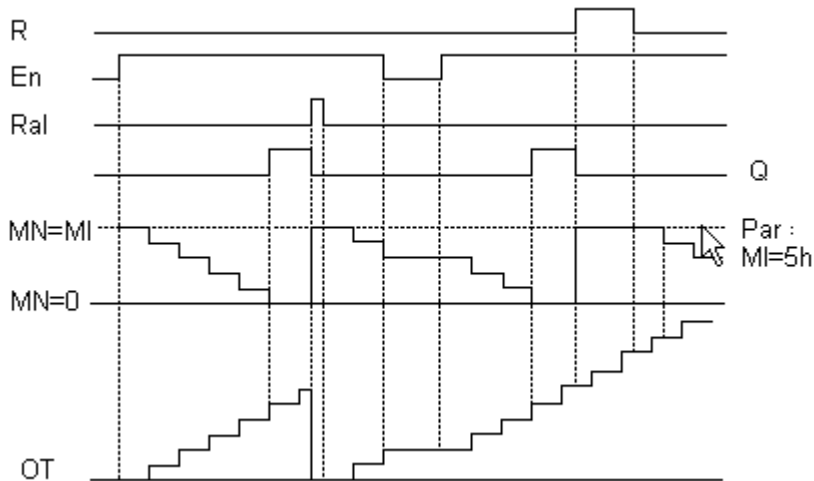

MI = Configured time interval

MN = Time-to-go

OT = Total time expired since the last 1 signal at the Ral input

These values are principally held retentive!

Parameter

The value of " M I " can be set and modified in parameter mode. For information about how to modify, refer to chapter 4.2.2 please.

Description of the function

The hours counter monitors input En. As long as the status at this input is 1, xLogic calculates the time expired and the time-to-go MN. xLogic displays these times when set to configuration mode. The output is set to 1 when the time-to-go is equal to zero.

You reset output Q and the time-to-go counter to the specified value MI with a signal at input R. The operation hour counter OT remains unaffected.

You reset output Q and the time-to-go counter to the specified value MI with a signal at input Ral. The operation hour counter OT is reset to 0.

Depending on your configuration of the Q parameter, the output is either reset with a reset signal at input R or Ral, or when the reset signal is 1 or the En signal is 0.



Limit value of OT

The value of the operating hours in OT are retained when you reset the hours counter with a signal at input R. The hours counter OT continues the count as long as $En = 1$, irrespective of the status at the reset input R. The counter limit of OT is 99999 h. The hours counter stops when it reaches this value.

In programming mode, you can set the initial value of OT. The counter starts operation at any value other than zero. MN is automatically calculated at the START, based on the MI and OT values.

Example: MI = 100, OT = 130, the result is MN = 70

Parameter preset

In xLogicsoft, you can define MI and an OT start value.

You determine that Q does not depend on En by selecting the corresponding check box.

Retentivity with the hours counter

The hours counter in the xLogic is generally retentive.

However, if the values of the hours counter are lost after a power failure, then select the respective block in your circuit program. Right mouse click on the hours counter and select **Block Properties > Parameters**. The option **Retentivity** must be activated and not changeable (grayed out).

If the **Retentivity** option is not available, then delete the block and insert a new special function **hours counter** at the same position.

3.4.15 Threshold trigger



Short description

The output is switched on and off, depending on two configurable frequencies.



Connection	Description
Input Fre	The function count 0 to 1 transitions at input Fre. ! to 0 transitions are not counted. Use <ul style="list-style-type: none"> Inputs I8(ELC-12) or IB/IC(ELC-18) for fast counts max. 99 kHz. Any other input or circuit element for low frequencies (typical 4 Hz).
Parameter	On: On threshold Range of values: 0000...9999 Off: Off threshold Range of values: 0000...9999 G_T: Time interval or gate time during which the input pulses are measured. Range of values: 00:05 s...99:99 s
Output Q	Q is set or reset according to the threshold values.

Parameter

The value of " On ", " Off " can be set/modified in parameter mode. For information about how to modify, refer to chapter 4.2.2 please.

Timing diagram

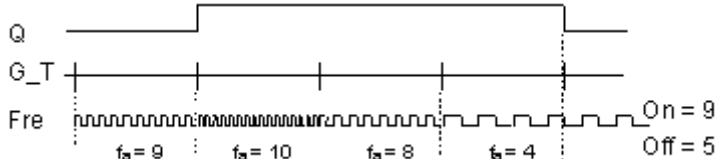

f_a = Input frequency

Description of the function

The trigger measures the signals at input Fre. The pulses are captured during a configurable period G_T.

Q is set or reset according to the set thresholds. See the following calculation rule.

Calculation rule

- If the threshold (On) > threshold (Off), then:
 - Q = 1, if $f_a \geq \text{On}$
 - Q = 0, if $f_a < \text{Off}$.



- If the threshold (On) < threshold (Off), then $Q = 1$, if $On \leq fa < Off$.

3.4.16 Latching relay

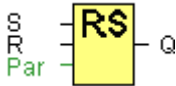

Short description

A signal at input S sets output Q. A signal at input R resets output Q.

Connection	Description
Input S	Set output Q with a signal at input S (Set).
Input R	Reset output Q with a signal at input R (Reset). Output Q is reset if S and R are both set (reset has priority over set).
Parameter	Retentivity set (on) = the status is retentive in memory.
Output Q	Q is set with a signal at input S and remains set until it is reset with signal at input R.

No parameter of Latching relay can be set/modified in parameter mode .

Timing diagram

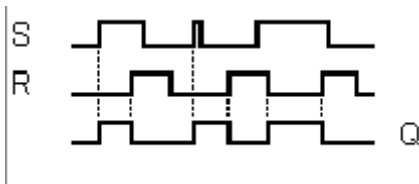

Description of the function

The latching relay represents a simple binary memory logic. The output value depends on the input states and the previous status at the output.

Logic table of the latching relay:

S	R	Q	Remark
0	0	x	Status unchanged



0	1	0	Reset
1	0	1	Set
1	1	0	Reset

When retentivity is enabled, the output signal corresponds with the signal status prior to the power failure.

3.4.17 Pulse relay

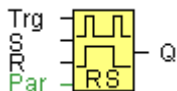

Short description

The output is set and reset with a short one-shot at the input.

Connection	Description
Input Trg	You switch output Q on or off with a signal at input Trg (Trigger) input.
Input S	A one-shot at input S (Set) sets the output to logical 1.
Input R	A one-shot at input R (Reset) resets the output to logical 0.
Parameter	Selection: RS (input R priority), or SR (input S priority) Retentivity set (on) = the status is retentive in memory.
Output Q	Q is switched on with a signal at Trg and is reset again at the next Trg pulse, if both S and R = 0.

No parameter of Latching relay can be set/modified in parameter mode .

Timing diagram

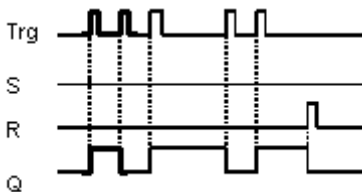

Description of the function

The status of output Q changes with each 0 to 1 transition at input Trg and if both S and R = 0, i.e. the output is switched on or off.

Input Trg does not influence the SFB when S = 1 or R = 1.

A one-shot at input S sets the pulse relay, i.e. the output is set to logical 1.

A one-shot at input R resets the pulse relay to its initial state, i.e. the output is set to logical 0.

Either the input R takes priority over input S (i.e. the signal at input S has no effect as long as R = 1), or the input S takes priority over input R (i.e. the signal at input R has no effect as long as S = 1), depending on your configuration.

3.4.18 Message text



Short description

Display parameterized message texts and parameters of other blocks in RUN mode.

Connection	Description
Input En	A 0 to 1 transition at En (Enable) triggers the output of the message text.
Input P	P is the priority of the message text. 1 is the lowest, 32 is the highest priority. Quit: Acknowledgement of the message text
Parameter	Text: Input of the message text Par: Parameter or actual value of another, already configured function (see "Visible parameters or actual values") Time: Shows the continuously updated time-of-day Date: Shows the continuously updated date EnTime: Shows the time of the 0 to 1 transition EnDate: Shows the 0 to 1 transition of the date
Output Q	Q remains set as long as the message text is queued.

Description of the function

With a 0 to 1 transition of the signal at input En, the display outputs your configured message text (actual value, text, TOD, date) in RUN mode.

Acknowledgement disabled (Ack = Off):



The message text is hidden with a 0 to 1 signal transition at input En.

Acknowledgement enabled (Ack = On):

After input En is reset to 0, the message text is displayed until acknowledged by pressing the OK button. The message text cannot be acknowledged as long as input En is high.

If several message text functions were triggered with En=1, the message with the highest priority (1 = lowest, 32=highest) is displayed. This also implies that a new message text is only displayed if its priority is higher than that of previously enabled message texts.

After a message text is disabled or acknowledged, the function automatically shows the previously active message text that takes the highest priority.

You can change between the display in RUN mode and the message texts by means of buttons.

Restrictions

Up to 32 message text functions are available.

Particular characteristics to be noted when configuring

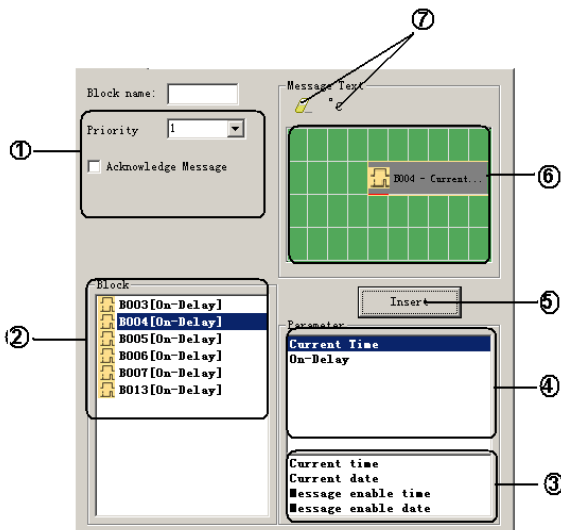

1 "General" area

Here you will find the following settings:

- Priority of the message text
- Check box for message text acknowledgement



2 **"Blocks" area**

Shows a list of all the circuit program blocks and their parameters.

3 **"General parameters" area**

Shows general parameters such as the current date.

4 **"Block parameters" area**

Shows the parameters of a block selected from the "Blocks" area which you can output in the message text.

5 **"Insert" button**

Button for inserting a parameter selected from the "Block parameters" area.

"Block parameters" or **"General parameters"** area into the message text.

6 **"Messages" area**

You arrange the message text in this area. Information entered in this area corresponds with that on the xLogic display.

7 **"Delete" button**

Button for deleting entries from the **"Messages"** area

"Special characters" button

Button for inserting special characters in the **"Messages"** area

To arrange the message text

1. From the **"Blocks"** area, select the block whose parameters you want to output.
2. Drag and drop the parameters required from the **"Block parameters"** to the **"Messages"** area. You may also use the **"Insert"** button to do so.
3. In the **"Messages"** area, you can add parameter data as required.

Particular characteristics to be noted when configuring



The message text can be configured in the block properties dialog. You can enter up to 4 lines for each message text (the text display of the xLogic has 4 x 10 characters) and set the priority. You can move to the next line using the cursor keys or the mouse. Hit the [ENTER] key to confirm all your entries in the block properties dialog and to close the dialog.

You may also enter the actual values of other blocks in the text lines. To do so, select the relevant block from the Block dialog. A Parameter dialog opens to display a list of all parameters available for the selected block. The block parameter you select in this dialog is written to the selected text line. The actual parameter value is now included when you call the message text.

Set the "Acknowledge message" attribute to specify whether a message is be acknowledged before it is closed.

3.4.19 Softkey

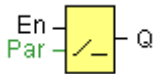

Short description

This SFB provides the action of a mechanical pushbutton or switch.

Connection	Description
Input En	Output Q is set with a 0 to 1 signal transition at input En (Enable) and if, in addition, 'Status=On' has been confirmed in configuration mode.
Parameter	Type: Sets either a pushbutton action for one cycle or a switching action of the function. Status: On or Off state that is applied in the initial cycle after program startup, is retentivity is not set. Retentivity set (on) = the status is retentive in memory.
Output Q	Output Q remains set 1, as long as En=1 and the status at the parameter Type = Switch and Status = On. Output Q is set for the duration of one cycle if EN=1 and the status at the parameters Type = momentary (pushbutton) and Status = On.

The status of this switch can be changed momentarily in parameter mode. For information about how to modify ,refer to chapter 4.2.2 please.

Factory state



Default of 'Type' is 'momentary action switch'.

Timing diagram

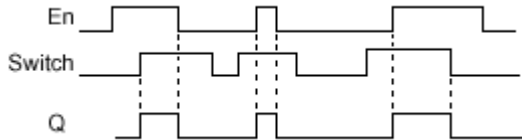

Description of the function

The output is set, when input En is set and the 'Status' parameter is set to 'On' and confirmed with OK. This action is performed irrespective of a configured switch or pushbutton function.

The output is reset to '0' in the following three cases:

- With a 1 to 0 signal transition at input En.
- When a pushbutton function is configured and one cycle has expired after its actuation.
- When the 'Status' parameter sets the 'Off' status in configuration mode, and this has been confirmed with OK.

Particular characteristics to be noted when configuring

The softkey can be used both with momentary pushbutton or switching action. At the status parameter you can define the on (actuated) or off state for the switch/pushbutton.

If the softkey is assigned a pushbutton action, the output is always set for the duration of one cycle with a 0 to 1 transition at input En when the pushbutton is in on state, or if the pushbutton state changes from Off to On when En=1.

3.4.20 Shift register



Short description



The shift register function can be used to read an input value and to shift the bits. The output value corresponds with the configured shift register bit. The shift direction can be changed at a special input.

Connection	Description
Input In	The function when started reads this input value.
Input Trg	The SFB is started with a positive edge (0 to 1 transition) at input Trg (Trigger). A 1 to 0 transition is irrelevant.
Input Dir	You define the shift direction of the shift register bits S1...S8 at the Dir input: Dir = 0: shift up (S1 >> S8) Dir = 1: shift down (S8 >> S1)
Parameter	Shift register bit that determines the value of output Q. Possible settings: S1 ... S8 Retentivity set (on) = the status is retentive in memory.
Output Q	The output value corresponds with the configured shift register bit.

No parameter of Latching relay can be set/modified in parameter mode .

Timing diagram

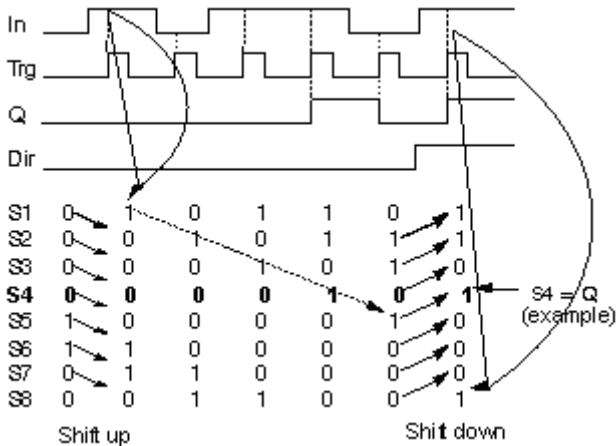

Description of the function

The function reads the value of input In with a positive edge (0 to 1 transition) at input Trg (Trigger).



This value is written to shift register bits S1 or S8, depending on the set shift direction:

- Shift up: S1 accepts the value of input In; the previous value of S1 is shifted to S2, S2 is shifted to S3, etc.
- Shift down: S8 accepts the value of input In; the previous value of S8 is shifted to S7, S7 is shifted to S6, etc.

Q outputs the value of the configured shift register bits.

If retentivity is not enabled, the shift function restarts at S1 or S8 after a power failure.

Note

The special function shift register can be used only once in the circuit program.

3.4.21 Analog comparator



Short description

The output is set and reset depending on the difference $A_x - A_y$ and on two configurable thresholds.

Connection	Description
Inputs Ax, Ay	Input the analog signals of which you want to determine the delta at the inputs Ax and Ay. Use the analog inputs AI1...AI8, the analog outputs AQ1 and AQ2. AI1..AI8: 0 - 10 V corresponds with 0 - 1000 (internal value).
Parameter	A: Gain Range of values: ± 10.00



	<p>B: Zero offset Range of values: $\pm 10,000$</p> <p>On: On threshold Range of values: $\pm 20,000$</p> <p>Off: Off threshold Range of values: $\pm 20,000$</p> <p>p: Number of decimals Range of values: 0, 1, 2, 3</p>
Output Q	Q is set or reset depending on the set thresholds.

Parameter p (number of decimals)

Applies only to Ax, Ay, Delta, On and Off values displayed in a message text.

Does not apply to the comparison of on and off values! (The compare function ignores the decimal point.)

The value of " On ", " Off " and " Dec " can be set/modified in parameter mode. For information about how to set/modify ,refer to chapter 4.2.2 please.(Dec means decimal point.)

Timing diagram

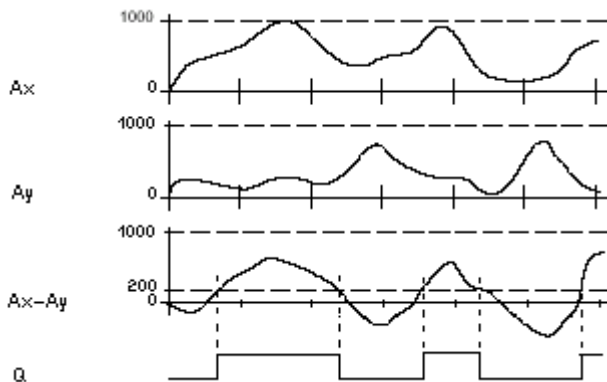

Q for $Ax - Ay > 200$, On = Off = 200

Description of the function

The function reads the value of the signal at the analog input Ax.

This value is multiplied by the value of parameter A (gain). Parameter B (offset) is added to the product, hence



$(A_x \cdot \text{gain}) + \text{offset} = \text{Actual value } A_x.$

$(A_y \cdot \text{gain}) + \text{offset} = \text{Actual value } A_y.$

Output Q is set or reset depending on the difference of the actual values $A_x - A_y$ and the set thresholds. See the following calculation rule.

Calculation rule

- If threshold On \geq Threshold Off, then:
 - $Q = 1$, if (actual value A_x - actual value A_y) $>$ On
 - $Q = 0$, if (actual value A_x - actual value A_y) \leq Off.
- If threshold On $<$ Threshold Off, then $Q = 1$, falls:
 - On \leq (actual value A_x - actual value A_y) $<$ Off.

Reducing the input sensitivity of the analog comparator

You can delay the output of the analog comparator selectively by means of the "on delay" and "off delay" SFBs. By doing so, you determine that output Q is only set if the input trigger length Trg (= output of the analog comparator) exceeds the defined on delay time.

This way you can set a virtual hysteresis, which renders the input less sensitive to short changes.

Particular characteristics to be noted when configuring

For help on analog block parameters, refer to the Analog value processing section.

3.4.22 Analog threshold trigger



Short description

The output is set or reset depending on two configurable thresholds (hysteresis).



Connection	Description
Input Ax	Input the analog signal to be evaluated at input Ax. Use the analog inputs AI1...AI8, the analog outputs AQ1 and AQ2. 0 - 10 V is proportional to 0 - 1000 (internal value).
Parameter	A: Gain Range of values: ± 10.00 B: Zero offset Range of values: $\pm 10,000$ On: On threshold Range of values: $\pm 20,000$ Off: Off threshold Range of values: $\pm 20,000$ p: Number of decimals Range of values: 0, 1, 2, 3
Output Q	Q is set or reset depending on the set thresholds.

Parameter p (number of decimals)

Applies only to the display of On, Off and Ax values in a message text.

Does not apply to the comparison of On and Off values! (The compare function ignores the decimal point.)

The value of " On " , " Off " and " Dec " can be set/modified in parameter mode. For information about how to set/modify ,refer to chapter 4.2.2 please.(Dec means decimal point.)

Timing diagram

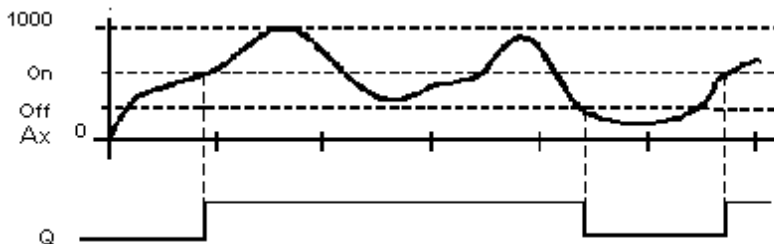

Description of the function

The function reads the value of the signal at the analog input Ax.



This value is multiplied by the value of parameter A (gain). Parameter B (offset) is added to the product, hence

$$(A_x \cdot \text{Gain}) + \text{Offset} = \text{Actual value } A_x.$$

Output Q is set or reset depending on the set threshold values. See the following calculation rule.

Calculation rule

- If threshold (On) \geq threshold (Off), then:
 $Q = 1$, if the actual value $A_x > \text{On}$
 $Q = 0$, if the actual value $A_x \leq \text{Off}$.
- If threshold (On) $<$ threshold (Off), then $Q = 1$, if
 $\text{On} \leq$ the actual value $A_x < \text{Off}$.

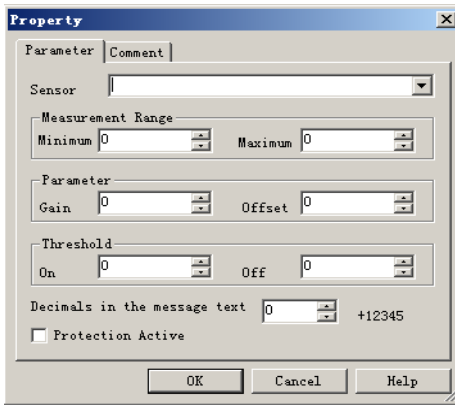

Note

The decimal point setting must be identical in the min. and max. range.

3.4.23 Analog amplifier

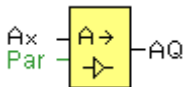

Short description

This SFB amplifies an analog input value and returns it at the analog output.

Connection	Description
Input Ax	Input the analog signal to be amplified at input Ax. Use the analog inputs AI1...AI8, the analog outputs AQ1 and AQ2. AI1..AI8: 0 - 10 V corresponds with 0 - 1000 (internal value).
Parameter	A: Gain Range of values: ± 10.00 B: Zero offset Range of values: ± 10000 p: Number of decimals Range of values: 0, 1, 2, 3
Output AQ	Analog output Value range for AQ: -32768...+32767

Parameter p (number of decimals)

Applies only to the display of Ax and Ay values in a message text.

Does not apply to the comparison of On and Off values! (The compare function ignores the decimal point.)

Description of the function

The function reads the value of an analog signal at the analog input Ax.

This value is multiplied by the gain parameter A. Parameter B (offset) is added to the product, i.e.

$(Ax \cdot \text{gain}) + \text{offset} = \text{Actual value Ax.}$

3.4.24 Analog value monitoring



Short description



This special function saves the process variable of an analog input to memory, and sets the output when the output variable exceeds or drops below this stored value plus a configurable offset.

Connection	Description
Input En	A positive edge (0 to 1 transition) at input En saves the analog value at input Ax ("Aen") to memory and starts monitoring of the analog range $Aen \pm \Delta$.
Input Ax	You apply the analog signal to be monitored at input Ax. Use the analog inputs AI1...AI8, the analog outputs AQ1 and AQ2. 0 - 10 V is proportional to 0 - 1000 (internal value).
Parameter	A: Gain Range of values: ± 10.00 B: Zero offset Range of values: $\pm 10,000$ Delta: Difference value for the Aen on/off threshold Range of values: $\pm 20,000$ p: Number of decimals Range of values: 0, 1, 2, 3
Output Q	Q is set/reset, depending on the stored analog value and the offset.

Parameter p (number of decimals)

Applies only to the display of Aen, Ax and Delta values in a message text.

Timing diagram



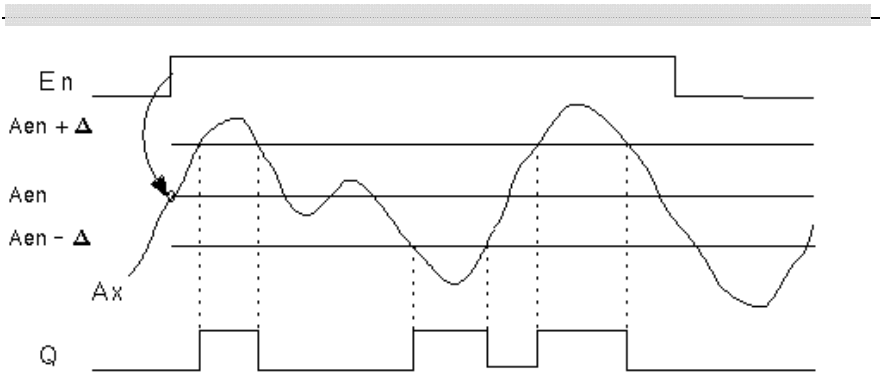

Description of the function

A 0 to 1 transition at input E_n saves the value of the signal at the analog input A_x . This saved process variable is referred to as A_{en} .

Both the analog actual values A_x and A_{en} are multiplied by the value at parameter A (gain), and parameter B (offset) is then added to the product, i.e.

$(A_x \cdot \text{gain}) + \text{offset} = \text{Actual value } A_{en}$, when input E_n changes from 0 to 1, or

$(A_x \cdot \text{gain}) + \text{offset} = \text{Actual value } A_x$.

Output Q is set when the signal at input $E_n = 1$ and if the actual value at input A_x is out of range of $A_{en} \pm \Delta$.

Output Q is reset, when the actual value at input A_x lies within the range of $A_{en} + \Delta$, or when the signal at input E_n changes to 0.

3.4.25 Analog differential trigger

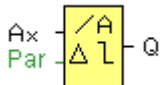

Short description

The output is set and reset depending on a configurable threshold and a differential value.

Connection	Description
------------	-------------



Input Ax	You apply the analog signal to be analyzed at input Ax. Use the analog inputs AI1...AI8, the analog outputs AQ1 and AQ2. 0 - 10 V is proportional to 0 - 1000 (internal value).
Parameter	<p>A: Gain Range of values: ± 10.00</p> <p>B: Zero offset Range of values: $\pm 10,000$</p> <p>On: On threshold Range of values: $\pm 20,000$</p> <p>Delta: Differential value for calculating the off parameter Range of values: $\pm 20,000$</p> <p>p: Number of decimals Range of values: 0, 1, 2, 3</p>
Output Q	Q is set or reset, depending on the threshold and difference values.

Parameter p (number of decimals)

Applies only to the display of On, Off and Ax values in a message text.

Does not apply to the comparison of On and Off values! (The compare function ignores the decimal point.)

Timing diagram A: Function with negative difference Delta

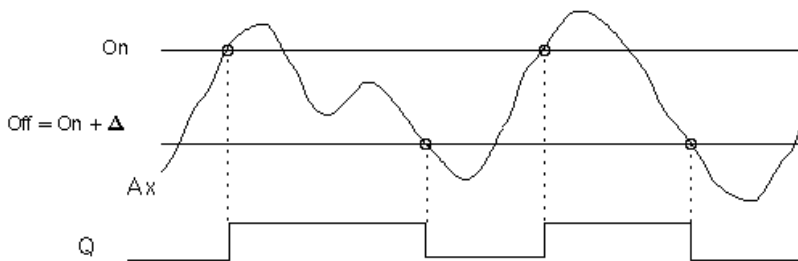

Timing diagram B: Function with positive difference Delta



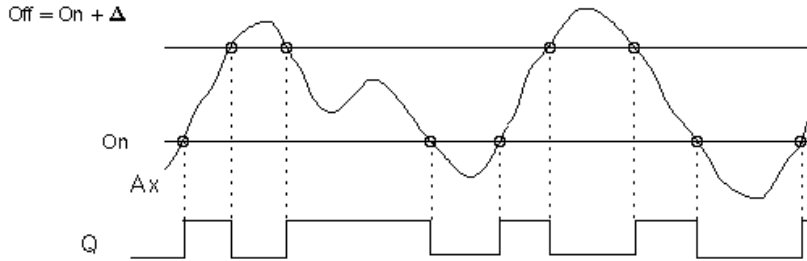

Description of the function

The function fetches the analog signal at input Ax .

Ax is multiplied by the value of the A (gain) parameter, and the value at parameter B (offset) is added to product, i.e.

$(Ax \cdot gain) + offset = \text{actual value of } Ax$.

Output Q is set or reset, depending on the set (On) threshold and difference value (Delta). The function automatically calculates the Off parameter: $Off = On + Delta$, whereby Delta may be positive or negative. See the calculation rule below.

Calculation rule

- When you set a negative differential value Delta, the On threshold \geq Off threshold, and:
 - $Q = 1$, if the actual value $Ax > On$
 - $Q = 0$, if the actual value $Ax \leq Off$.

See the timing diagram A.
- When you set a positive differential value Delta, the On threshold $<$ the Off threshold, and $Q = 1$, if:
 - $On \leq \text{the actual value } Ax < Off$.

See the timing diagram B.



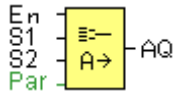

Short Description

This special function displays 0 or one of 4 saved analog values on the analog output.

Connection	Description
Input En	1 on input En (Enable) switches, dependent on S1 and S2, a parameterized analog value to the output AQ. 0 on input EN switches 0 to the output AQ.
Inputs S1 and S2	S1 and S2 (selectors) for selecting the analog value to be issued. S1 = 0 and S2 = 0: The value 1 is issued S1 = 0 and S2 = 1: The value 2 is issued S1 = 1 and S2 = 0: The value 3 is issued S1 = 1 and S2 = 1: The value 4 is issued
Parameter	V1...V4 : Analog values (Value) that will be issued. Value range: -32768...+32767 p : Number of decimal places value range: 0, 1, 2, 3
Output AQ	Analog output Value range for AQ: -32768...+32767

Parameter P (number of decimal places)

Applies only to the display of AQ, V1, V2, V3 and V4 values in a message text.

Timing Diagram



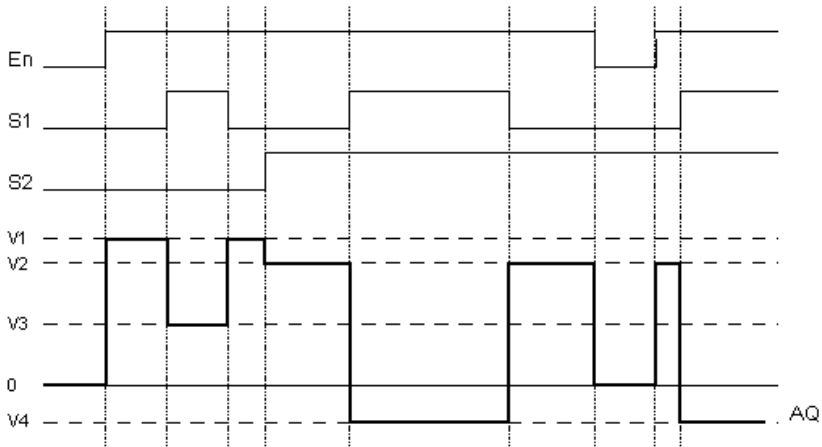

Description of Function

If input En is set, then the function issues one of 4 possible analog values V1 to V4 at the output AQ, depending on the parameters S1 and S2.

If the input En is not set, then the function issues the analog value 0 at output AQ.

3.4.27 Peripheral



Short description:

When a high level in Trg, the peripheral block will be activated and the xLogic SuperRelay could communicate with peripheral as a master via RS232 or RS485 interface, further the output will be switched on when the value of external device's register is between the "On" and "Off" threshold value.



Connection	Description
Input Trg	A high signal in Trg input will enable "peripheral" function block to be activated
Input R	Reset the value read from peripheral and set the output to 0 via the R (Reset) input. Reset has priority over Trg.
Parameter	Communication protocol: Modbus(RTU) Register address of peripheral Communication parameter Communication interface of xLogic SuperRelay On: On threshold Off: Off threshold
Output Q	Q is set or reset depending on the set thresholds.

Note: Regarding Modbus RTU detail, please refer to our Modbus RTU communication protocol file for it.

Description of the function:

In the configuration of our xLogic communication, the xLogic SuperRelay usually serves as a slave via Modbus RTU Protocol, and can communicate with a master directly. That's to say, any device communicating with xLogic SuperRelay sends command to it, and the its response will be sent out only when the xLogic SuperRelay has received the command, Just as the below figure shows:

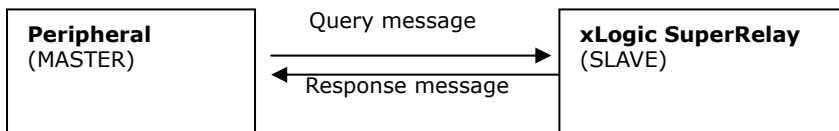

However , this "peripheral" function block would be utilized if xLogic SuperRelay shall be required to play a role of master to communicate with other devices. As the following figure shows:

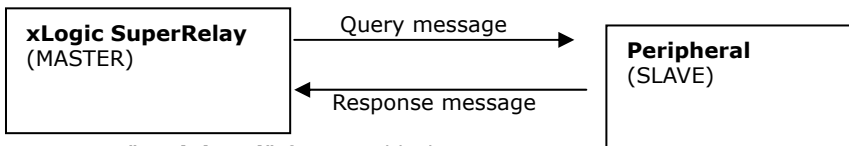

When you put "**Peripheral**" function block in your program and make some configurations ,the function that xLogic SuperRelay serves as master will be realized.



The Property in dialog box of "Peripheral" shows as below figure:

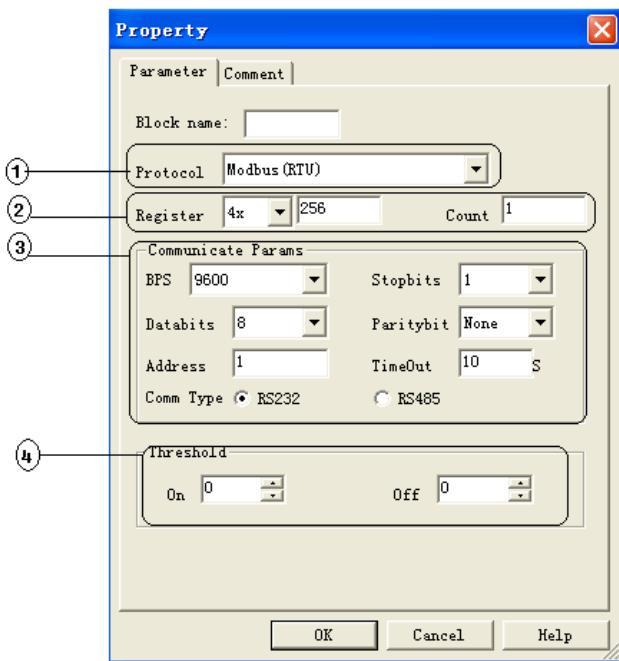

1. Communication protocol: Modbus(RTU)
2. Register address and the number of register
3. Communication parameters : BPS is buad rate 、 Stopbits 、 Databits 、 Communication type: RS232、 RS485 . Actually RS232 or RS485 are just interface of xLogic SuperRelay. Notes: RS485 interface is only applied to ELC-18 SERIES.
4. Threshold : Here you can set the "On" and "Off" threshold value.

Calculation rule

- If threshold (On) \geq threshold (Off), then:
Q = 1, if the value from external device $>$ On
- Q = 0, if the value from external device \leq Off.
- If threshold (On) $<$ threshold (Off), then
Q = 1, if On \leq the value from external device $<$ Off.



3.5 HMI (Human Machine Interface) Block

3.5.1 System cover

This block cannot directly be found in the block list ,however, it is set as default by system of xLogic, hence system cover can be available if you follow the below procedures : use your mouse to left-click "Tools" menu->select "Edit Cover HMI" by left-click in xLogicsoft .

Short description

Display the status (Run or Stop) of xLogic when power-on or simulation by soft. Particular characteristics to be noted when configuring

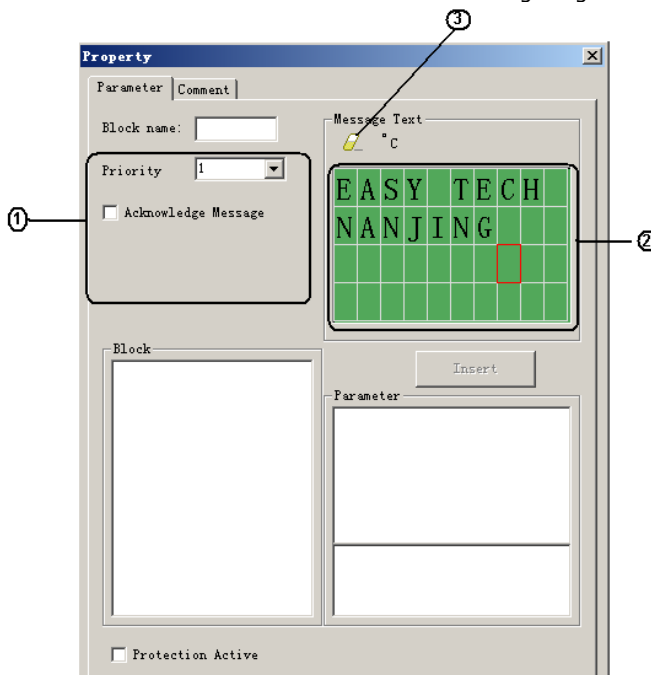

1. "General" area

Here you will find the following settings:·

Priority of the system cover

2. "Messages" area

Users can edit the messages in the first and second line, the third line displays the state RUN or STOP, and the messages saying whether your program has mistakes or not will be shown in the fourth line.

3. "Delete" button

Button for deleting the "Messages" in the first and second line.



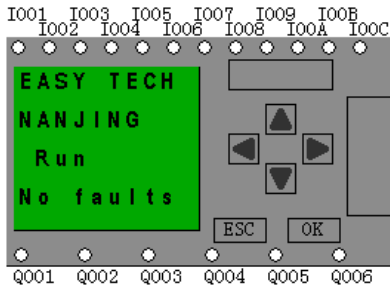

3.5.2 System input/output

H:1



Short description

Display the status of the input and output of the main and expansion modules.

Particular characteristics to be noted when configuring

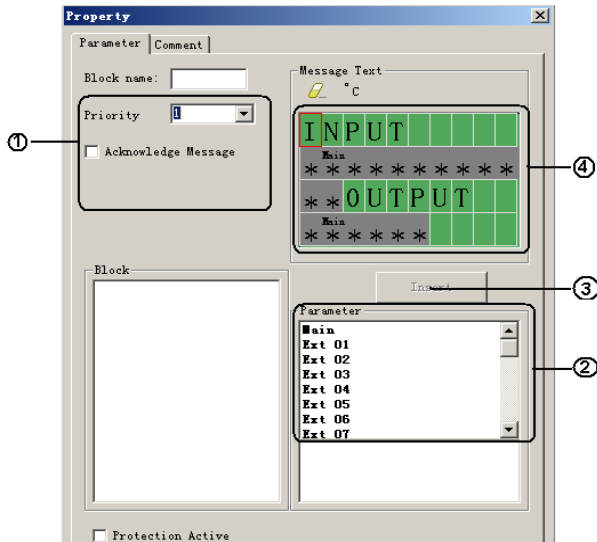

1. "General" area

Here you will find the following settings:

Priority of the system input and output.

2. "Blocks" area

Displaying all extendable and main modules can be inserted

3. "Insert" button

Button for inserting the selected blocks to the "Message" area.

4. "Message" area

Display input and output of the blocks you inserted.

The following figure would be shown when xLogic is power-on or under simulation status in soft.

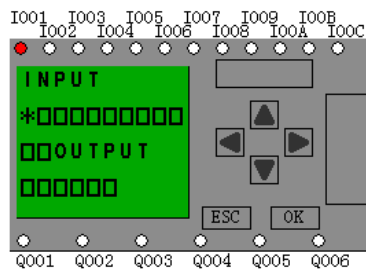

Note:

* represents high pulse, □ represents low pulse.

Description of the priority of HMI blocks:

If several HMI blocks are placed in the program, the messages in the respective block would be displayed according to priority level (1 = lowest, 32 = highest). After a message is disabled or acknowledged, the function automatically shows the previously active message text that takes the highest priority, but you can change the human machine interface via press the Left and Right key.



4. Configuring xLogic

The difference between LCD message of xLogic and the traditional LCD message

In the use of traditional LCD message, it can only display some fixed and simple message such as time, I/O status etc. It can not display the counter value, timer value and analogue value. And all the LCD message screens are set and programmed by the program engineer, so users can not change, add, or remove any message screen. The operation of the traditional LCD message screen is not easy to use for the end users. Regarding the above short comings of the traditional HMI module, we have adopted a new method to develop the xLogic, and offer to user a free, and easily LCD instruction. The powerful function of the LCD (can be called HMI) is as follows:

1. Providing 32 Human-Machine Interfaces

When using **xLogicsoft**, users can add HMI according to demand not more than 32. And the non-alarming interfaces can be seen on LCD panel.

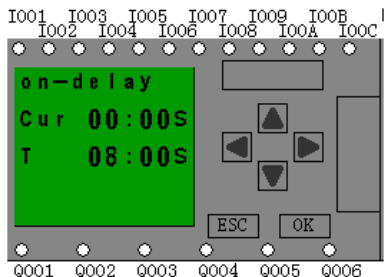

2. Providing Several HMI Blocks

Besides the system cover and system input/output blocks, the message text block can supply a large number of messages about your program. And the function of those blocks are described in chapter 3. Please read it in details.

4.1 Instruction of xLogic-HMI

After being powered on, xLogic shall self-check program stored in the main module.

If the program is accurate, then the main module will be running, meanwhile the system cover will show as follows:

In **xLogicsoft**, this interface is defaulted as its initialization screen.



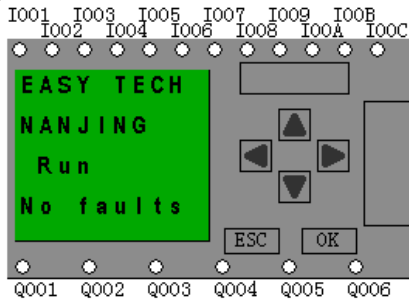

If there are several parameter pages, users may press ◀ or ▶ key to go to the page you would like. The last page is the cursor mode:

4 cursor is used to factitious interfere in the circuit program.

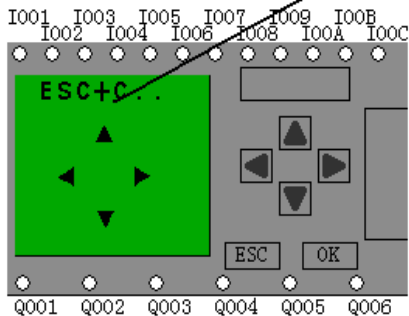

If xLogic has several alarm interfaces in the same period and it only displays the message with highest priority in the block, also you may go through all alarm messages by pressing ▲ or ▼ key.

Note:

The message text block would be treated as parameter page only when it has no input, otherwise, it may be regarded as alarm page. When input has high pulse, LCD shall display alarm message.

4. 2 Select function page

Press ESC key to change from running mode to function page.



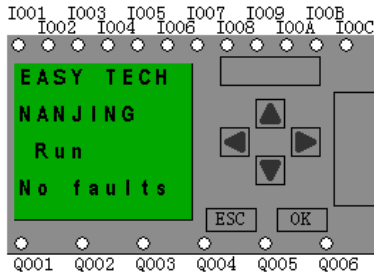

Press ESC...

After pressing ESC key, xLogic would be switched to function page and meanwhile open function menu as figure below shows.

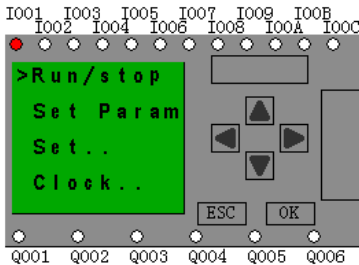

Brief introduction on four options of function page:

- **Run/stop**
Select this menu to switch over xLogic status between RUN and Stop. Refer to chapter 4.2.1 for details.
- **Set Param**
To set function block parameter. Refer to chapter 4.2.2 for details.
- **Set...**
Used to set /modify password and set address of expansion module, refer to chapter 4.2.3 and 4.2.4 for details please.

1. "Press ▲ or ▼ key to move the cursor to "Set..."
2. Then press **OK** key ,xLogic will display as follows:

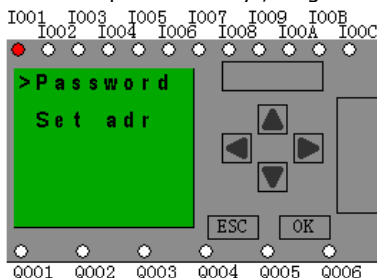

- **Clock**



To set and modify date and time .Refer to chapter 4.2.5 for details.

4.2.1 Run/Stop(Switch Over between Run & Stop Mode of the Main module)

You should first select FUNCTION PAGE.(read 4.2)

1. Move the cursor to "Run/stop": Press ▲ or ▼ key.
2. Confirm "Run/stop" :Press OK key.

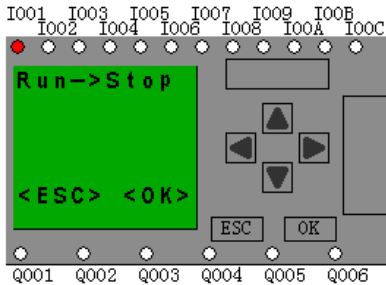

- 3.Then press the OK key.

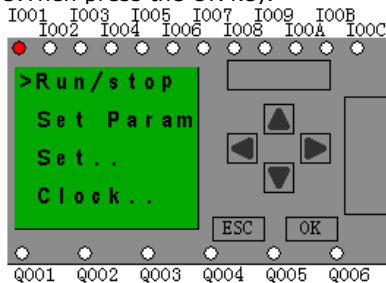

After pressing ESC key, you'll find out your circuit program has changed to "stop" status as figure below shows:

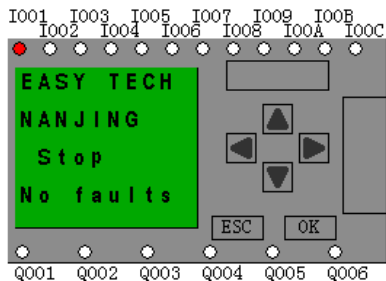

Summary:

you can transform the state(RUN or STOP) of the program via the three steps



mentioned above.

4.2.2 Set parameter

If you want to select a parameter, you may follow the following procedures:

1. Under the FUNCTION PAGE, select
 "Set parameter" : Press ▲ or ▼ key

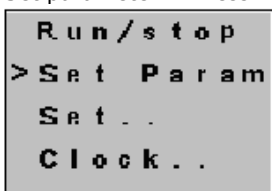

2. Confirm by pressing **OK** key.

Then xLogic displays the first parameter, so you can modify as you like. If there is no parameter to set/modify, you can press ESC key to return.

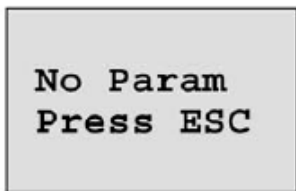
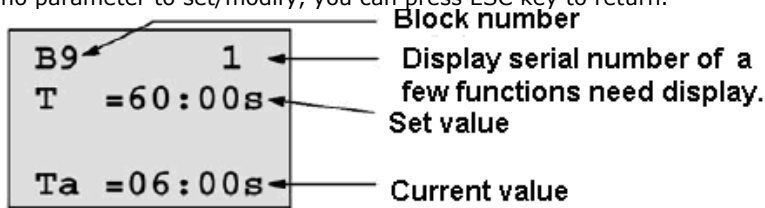

No parameter to edit ,press ESC key to return.

3. Select parameter you intend to modify.
4. Select certain specific value of that parameter which you want to edit ,then press OK key.

How to modify parameter?

- A. First select certain parameter which you need to edit by following the below



procedures:

- Under the FUNCTION PAGE, select "Set parameter": Press ▲ or ▼ key



- Confirm by pressing **OK** key.

B. then you can perform the below actions to modify parameter:

- Move the cursor to the parameter to be modified: press ◀ or ▶ key.
- Modify value: press ▲ or ▼ key.
- Confirm the value after modification: press OK key.

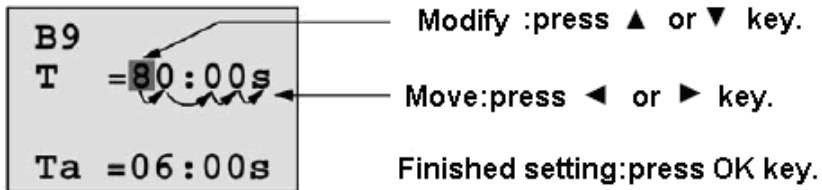

Note:

When xLogic is running, not only time value but also time unit(S,M,H) can be altered , but Besides alter time parameter at RUN time ,you can alter time base(s=second, m=minute ,h=hour).

Current value of time T

View time T in parameter mode:



```

B9
T  =80:00s ← Configuration time T
Ta =06:00s ← Current time
    
```

You are allowed to modify configuration time. Switch on/off time for a time segment.

In parameter mode, time segment figure of a timer:

```

B1      1
D=M-W-F--
On  =09:00
Off=10:00
    
```

You can alter the time and date of switch on/off.

Current value of counter

In parameter mode, the parameter view of a counter:

```

B3
On  =001234
Off=000000
Cnt=000120 ← Current count value
    
```

Current value of hour counter

In parameter mode, the view of hour counter:



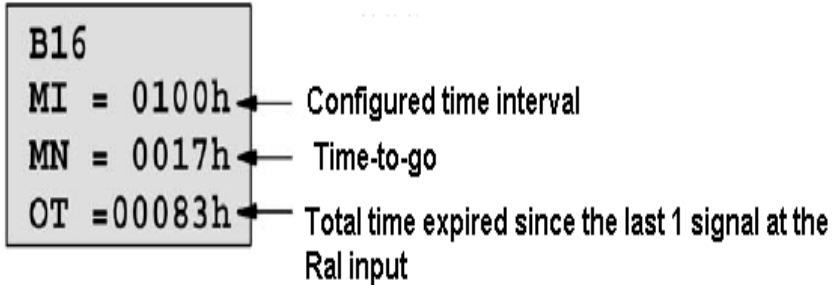

You can edit configured time interval (MI).

Current value of threshold trigger

In parameter mode, the view of threshold trigger:

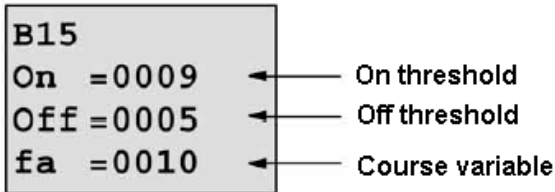

You can alter the threshold value of switching on /off.

4.2.3 Set password

xLogic supply password protection function for your program. You can choose according to your need. See the following instruction, you'll understand the method of setting password.

Set one password

A password contains less than or equal to 4 characters and each character is Arabian number from 0 to 9 .It is easy to specify, edit or remove the password directly on the xLogic in the "Password" menu of the function page:

You should first select the FUNCTION PAGE. (read 4.2)

1. Move the cursor to "Password": Press ▲ or ▼ key.
2. Confirm "Password": Press OK key.

Example: let us set "1234" as password for a program. Now the LCD displays the following interface:



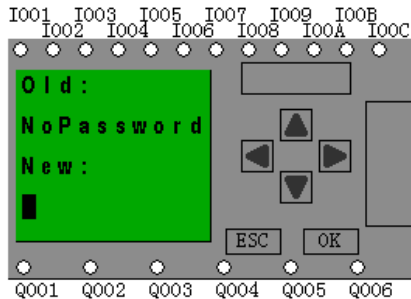

Select "New" option, then edit it.

3. select "1": press ▲ key once.
4. move the cursor to the next character: press ► key.
5. select "2": press ▲ key twice.
6. move the cursor to the next character: press ► key.
7. select "3": press ▲ key three times.
8. move the cursor to the next character: press ► key.
9. select "4": press ▲ key four times.

Now display:

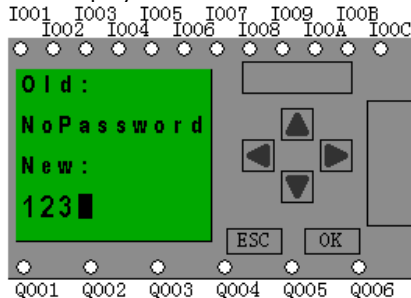

10. Confirm password: press OK key.

Now, the program is protected by the password of "1234", then you can return to the main menu.

Note:

You can cancel a password newly-set via ESC key. In this instance, xLogic will return to main menu and not reserve that password. You also can use **xLogicsoft** to set your password. You are not allowed to edit the program protected by password or transfer it to **xLogicsoft** unless you input a true password previously.

Modify password:



In order to modify password, you are required to present current password.

In the menu of the FUNCTION PAGE.:

1. Move the cursor to "Password": Press ▲ or ▼ key.
2. Confirm "Password": Press OK key.
Select "Old" and input primary password (in our instance is "1234"), the process is the same as the step 3 to step 10 mentioned above.

LCD displays:

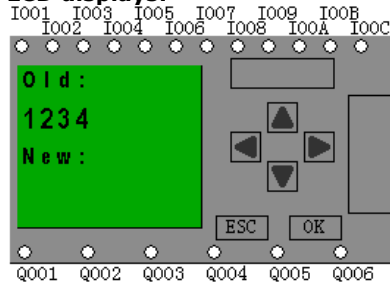

Thus, you could select "New" to input new password such as "8888":

3. select "8":press ▲ key.
4. move the cursor to next character: press ► key.
Repeat the step 3 and 4 to realize the third and fourth character.

LCD displays:

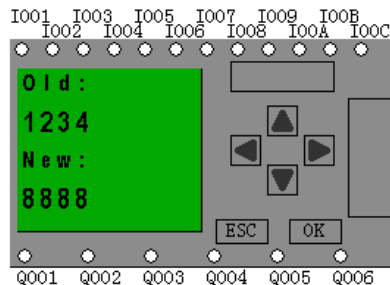

4. Confirm new password: press OK key.
So you have set the new password and then return to main menu.

How to remove the password:

In case you need to remove password .e.g. allow the other users to edit your program, then you must know the current password. the process of removing



password is the same as that of modifying password.

In the menu of the FUNCTION PAGE. :

1. Move the cursor to "Password": Press ▲ or ▼ key.
2. Confirm "Password": Press OK key.

Select "Old" and input primary password (in our instance is "1234"), the process is the same as the step 3 to step 10 mentioned above.

LCD displays as follows:

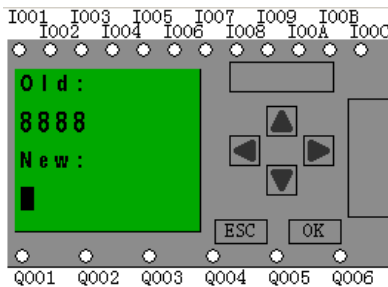

Input nothing under the "New", and let it keep blank to clear password.

5. Confirm "blank" password: press OK key. Now you have cleared password and return to main menu. If you want to set password next time ,the LCD will display:

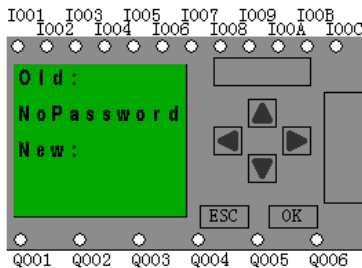

Note:

This action (removal) make password alert be prohibited , so your program can be reserved without password.

If users input wrong password and press OK key, xLogic doesn't enter edit page and return to main page. This process repeats again and again until you input the correct password.



4.2.4 Set Address of expansion module

You may set expansion module address to realize communication with main module of xLogic.

Note: Up to 31 expansion modules can be linked together. You shall first select the FUNCTION PAGE.(read 4.2)

1. Move the cursor to "Set adr": Press ▲ or ▼ key.
2. Confirm "Set adr" :Press OK key.

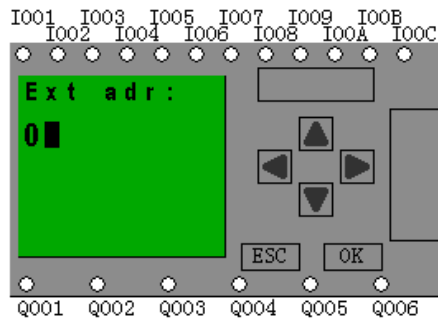

3. Move the cursor to the place of parameter to be modified: press ◀ or ▶ key.

6. Modify value: press ▲ or ▼ key.

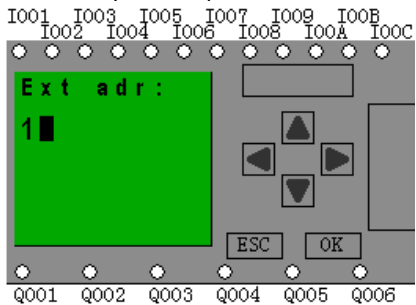

7. Confirm the value after modification: press OK key.

4.2.5 Modification Methods of System Time

You should first select the FUNCTION PAGE.(read 4.2)



1. Move the cursor to "Clock": Press ▲ or ▼ key.
2. Confirm "Clock" :Press OK key.

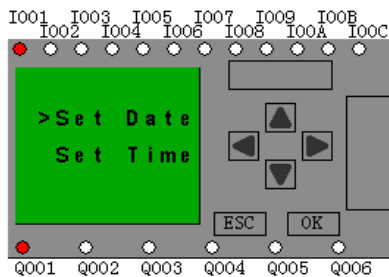

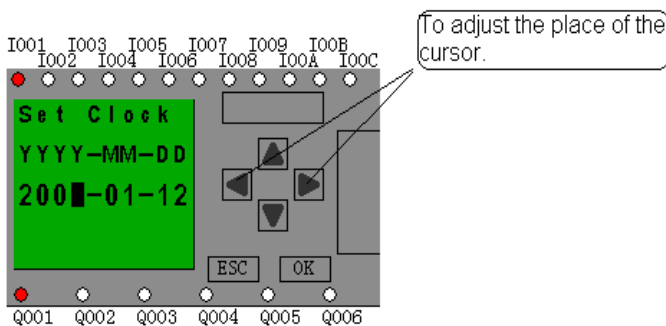

Press OK key to set and modify date.



Press  or  key to realize the date which you want to set .After you finished your setting, press OK key to return to :

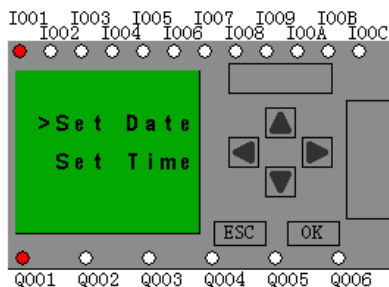

If you want to set the time further, please move the cursor to " Set Time" menu, then press OK key:



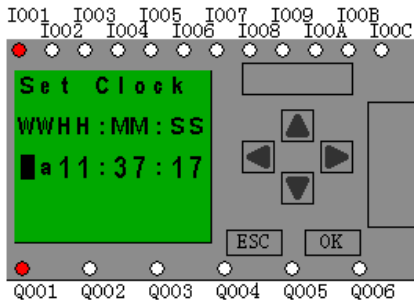

Here you can set week day (From Monday to Sunday) and the clock. The method is similar to above. After completion of your setup, press OK key:

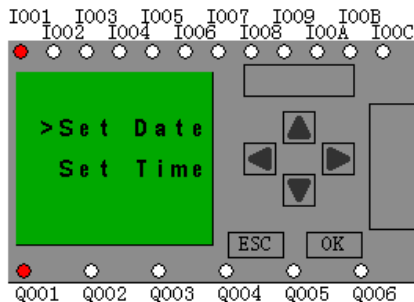

Press ESC key and return to FUNCTION PAGE.

5. Application

In order to let users know the far going application field of xLogic, we present a set of application example. Each instance includes the circuit program of its original solution and the compare of solution in which xLogic has been applied. You can find the following solution:

- Dual-function switch
- Automatic gate
- Ventilation system
- Industry door
- Daylight lamps
- Rain water pump

Note:

The application example of xLogic is available free of charge to our clients, but we can't make any promise, it is only to explain the general rule of using xLogic. It is



possible that these instances can be different from user's specific application, so user should take all related responsibility of running those instance systems, and we sincerely suggest user shall refer to relevant nation standard and installation rules related to systems.

Also, we have to point out that error is unavoidable, and we reserve the according modification rights.

5.1 Dual-function switch

Requirements for stairway lighting systems

The basic requirements for a stairway lighting system are as follows:

- When someone is using the stairs, the stairway lights should be on.
- If no one is in the stairway, the lights should go out in order to save energy.

5.1.1 Standard solution

Up to now two methods were known to control such a lighting system:

- Pulse relay: When the lights are off, press any of the pushbuttons to switch on the lights. When the lights are on, press any of the pushbuttons to switch off the lights again.

Disadvantage: People often forget to switch off the lights

- Automatic stairway light switch: Press any one of the pushbuttons to switch on the lights. The lights switch off again automatically when a preset off delay time has expired.

Disadvantage: You can't keep the lights switched on over an extended period of time. The permanent on switch, usually installed inside the stairway lighting timer unit, may be difficult or impossible to access.

The wiring is the same for both systems.



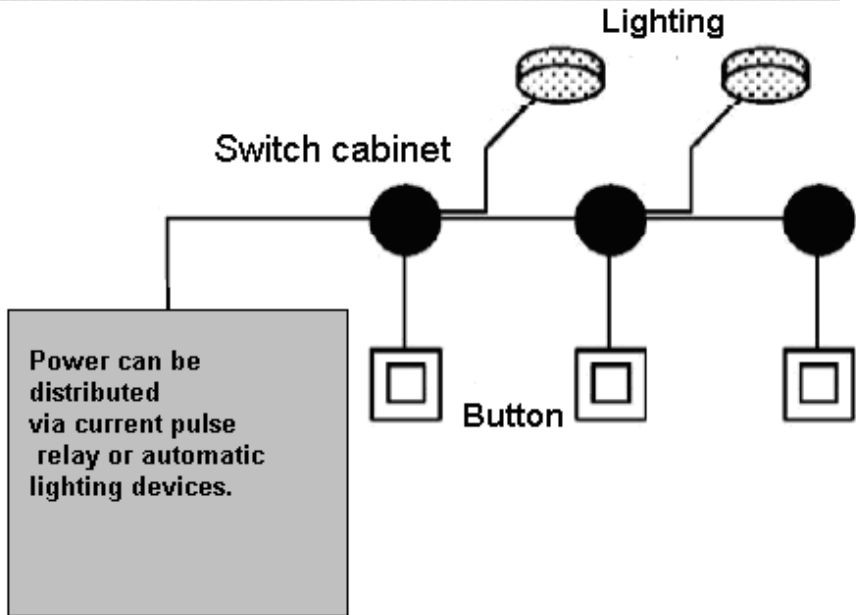

xLogicSoft solution

The xLogic system can replace the automatic stairway light switch or the pulse relay.

xLogic also lets you create a simple automatic stairway light switch via the stairway light switch SFB.

You can also implement both functions (off delay timer and pulse relay) in a single unit. What is more, you can incorporate extra functions without making any alterations to the wiring. In our example program, we have combined the advantages of both the current impulse relay and the automatic stairway lighting timer as follows:

- Actuate the pushbutton → The light is switched on and switched off again on expiration of a predefined time.
- Hold the pushbutton down → Switches on continuous lighting
- Press the pushbutton once more → Switches off the lighting



5.1.2 The scheme of ELC18AC

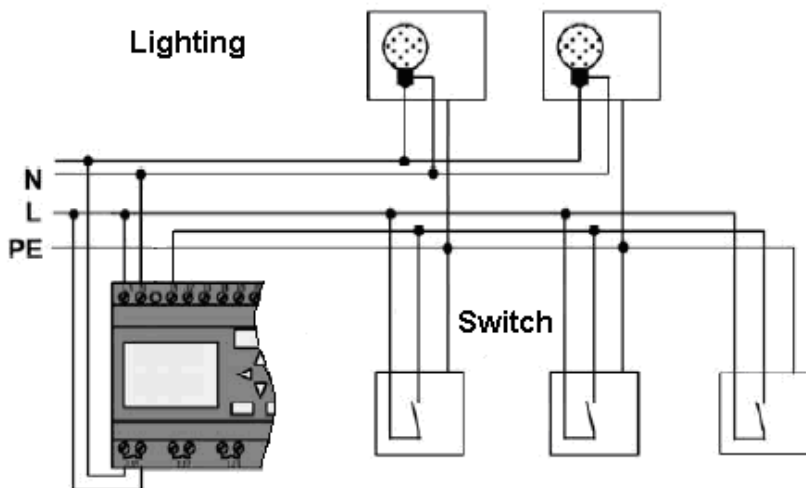

The wiring of a lighting system with xLogic is the same as standard corridor or stairway lighting systems. Only the automatic lighting timer/pulse relay is replaced.

xLogic lets you quickly and easily combine all those functions in a single dual-function switch SFB, without additional wiring and expenditure.

Apply pulse relay of xLogic

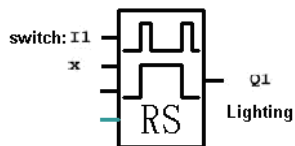

When the input "I1" has a pulse, the output "Q1" will be on or off.

Automatic stairway lighting system

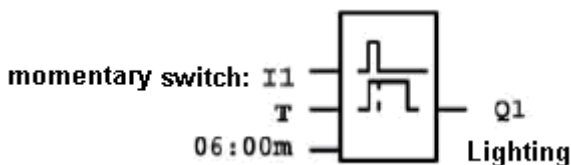

If input "I1" has a pulse, the output Q1 will be on and keep 6 minutes, then be off.

Apply xLogic to realize multiple switch

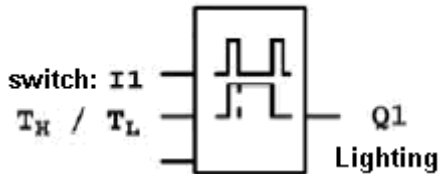

When the input "I1" has a pulse, the output "Q1" will be on and not off until the period "TH" be over.

Keep the momentary switch holding down in period "TL", the light will be on all the time.

Select special function

The following selection can be done as special function or saving energy sources:

- The lighting flicker before it gets off automatically.
- You can integrate different central control functions:
 - Central control off
 - Central control on(emergency button)
 - Control all lighting or certain single circuitry by lighting control switch.
 - To control by integrated timer.

5.2 Automatic gate

In the entrance of supermarket, public building, bank, hospital etc, automatic gate is often used.

The requirement of automatic gate

- If some people approach to gate, it will be opened automatically.
- The gate must remain open until there is no person on the passageway.
- If there is no person on the passageway, the gate must be off automatically in a minute.



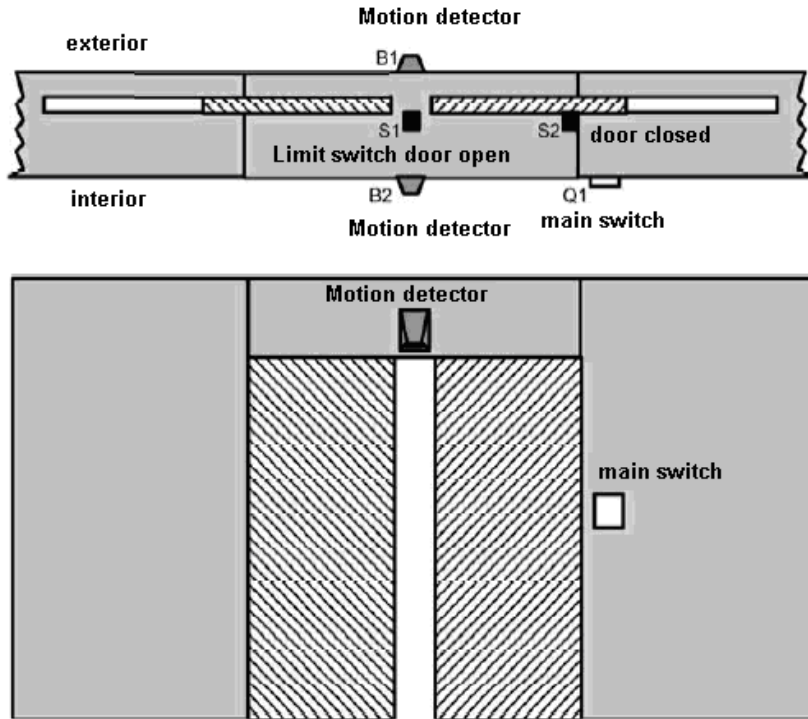

5.2.1 Standard solution



consult circuitry

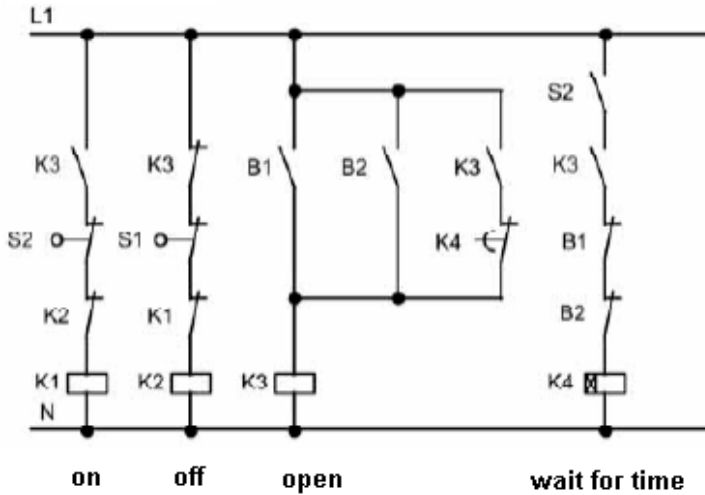

As long as the detector B1 or B2 detects someone approach, the switch K3 will be on and open the door.
 If the two detectors don't detect person in a short time, trigger K4 and close the door.

5.2.2 The scheme of ELC 18 AC

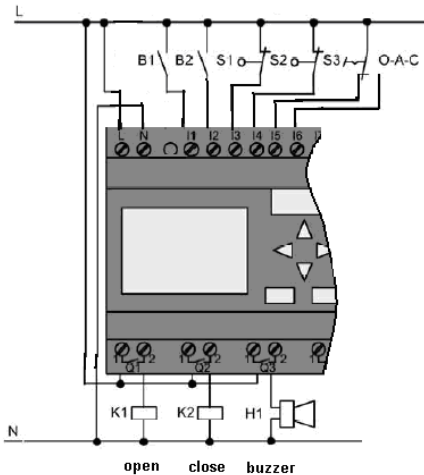

Required components:

- K1 open contactor
- K2 close contactor
- S1(break contact) close limit switch
- S2(break contact) open limit switch
- B1(make contact) outdoor infrared action detector
- B2(make contact) infrared action detector inside

xLogic function block circuit program:

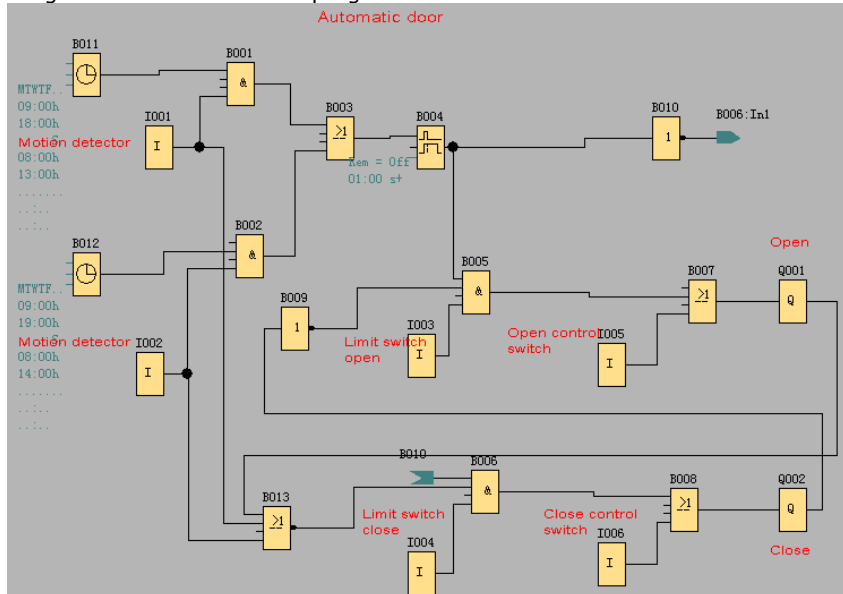

Motion detector

During business hours, if someone enters store, the detector B1 will trigger electricmotor to open the door, vice versa.

At closing time, the detector B2 make electromotor keep running for an hour to make more time for customer to leave.

Trigger electromotor for opening door

The output Q1 is switched on and triggers electromotor, when:

- Operate control switch I5(the door is open all the time)
- The detector indicates that somebody is approaching to the door.



- The door has not been opened entirely (I4 limit switch is not off).

Trigger electromotor for closing door

- Operate control switch I6(the door is closed all the time)
- The detector indicates that nobody is approaching the door.
- The door had not been closed entirely (I3 limit switch is not off).

Buzzer

Connect the buzzer to output Q3. When the door is going to be closed, the buzzer gives off sounds for a short time(1s in this example). To attach buzzer, need to connect the following circuit program to output Q3.

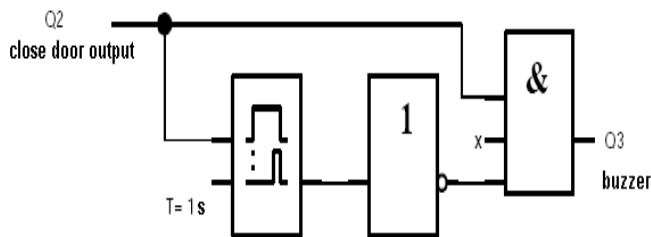

5.3 Ventilation system

Requirements for a Ventilation system

A Ventilation system supplies fresh air into a room and exhausts the contaminated air. Let us look at the following sample system:



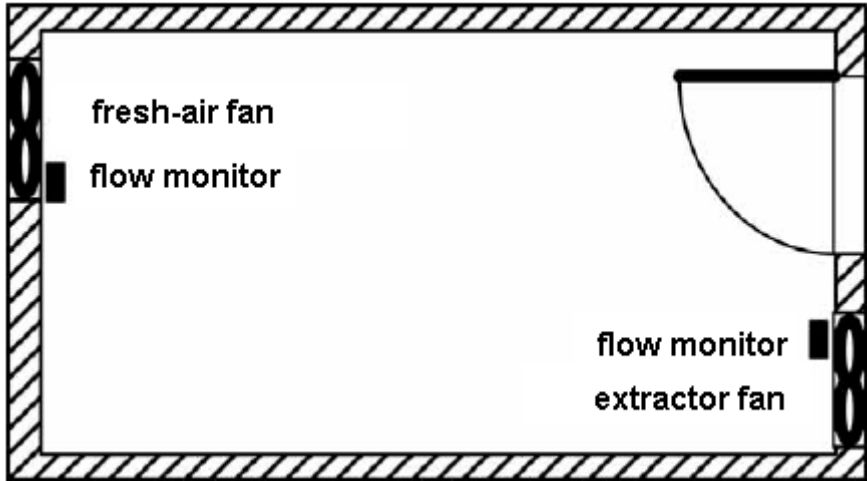

- A room contains an extractor fan and a fresh-air fan.
- Each fan is monitored by means of a flow sensor.
- The pressure in the room may rise above the atmospheric pressure.
- The fresh-air fan may only be switched on if the flow sensor signals the safe operational state of the extractor fan.
- A warning lamp indicates failure of one of the fans.

5.3.1 Standard solution

The control circuit diagram of Ventilation system formerly as follows:



Required components:

- K1 Main contactor
- K2 Main contactor
- S0(make contact) Off button
- S1(make contact) On button
- S2(break contact) Flow monitor
- S3(break contact) Flow monitor
- H1 Flashing lamp
- H2 Flashing lamp

xLogicSoft solution

The use of xLogic reduces the amount of switchgear. Thus, you save installation time and space in the control cabinet. You may even be able to use as a smaller control cabinet.

With xLogic you can also switch off of the fans sequentially after the system is switched off.

The circuit in xLogicSoft

The system is switched on and off at the inputs I1 and I2. The fans are connected to outputs Q1 and Q2, the flow sensors are connected to the inputs I3 and I4. Blocks B07 and B10 are used to set the watchdog times after which the flow sensors should send a signal to the fault output Q3.



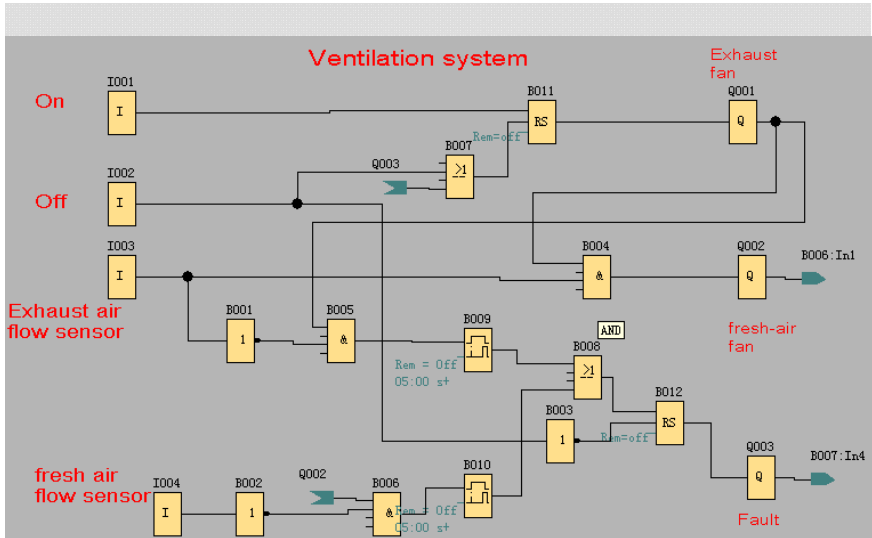

You can invert output Q3 to use output messages at Q4. Relay Q4 only drops out if main power is lost or if there is a fault in the system. The output can then be used for a remote message.

5.4 Factory door

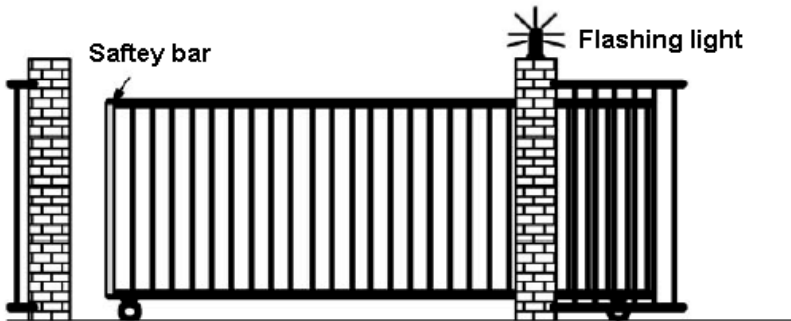

Requirements for a gate control system

In many cases a factory entrance is closed with roll gates. Those gates are only opened when vehicles need to enter or leave the factory grounds. The gate is controlled by the porter.

- The sliding gate is opened and closed by means of a pushbutton control in the gatehouse. The porter can monitor the gate operation.



- The roll gate is normally fully opened or it is closed. However, gate movements can always be interrupted.
- A flashing light is activated five seconds before the gate moves, and while the gate is in motion.
- A safety pressure strip ensures that people are not injured and that no objects are trapped and damaged when the gate is closing.

5.4.1 Standard solution

There are many different control systems for operating automatic gates. The OPEN and CLOSE buttons initiate gate movements into the relevant direction, provided it is not already moving in the opposite direction. Movement of the gate is terminated either by means of the STOP button or the relevant limit switch.

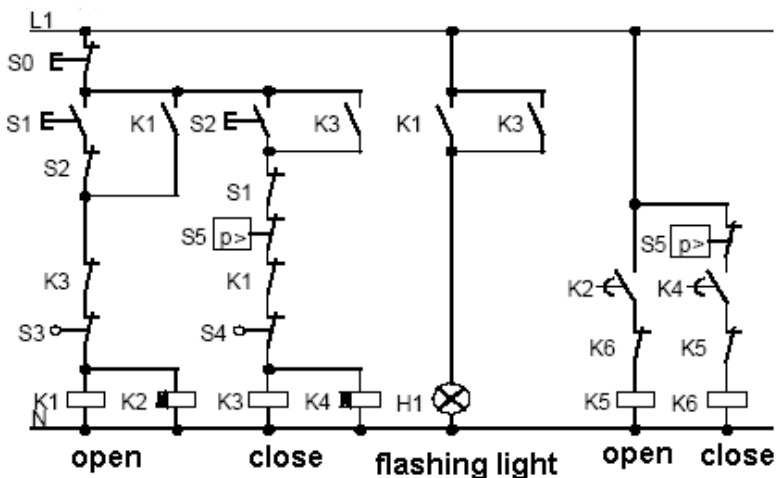

5.4.2 The scheme of ELC-18 AC

The circuit diagram of industry gate:



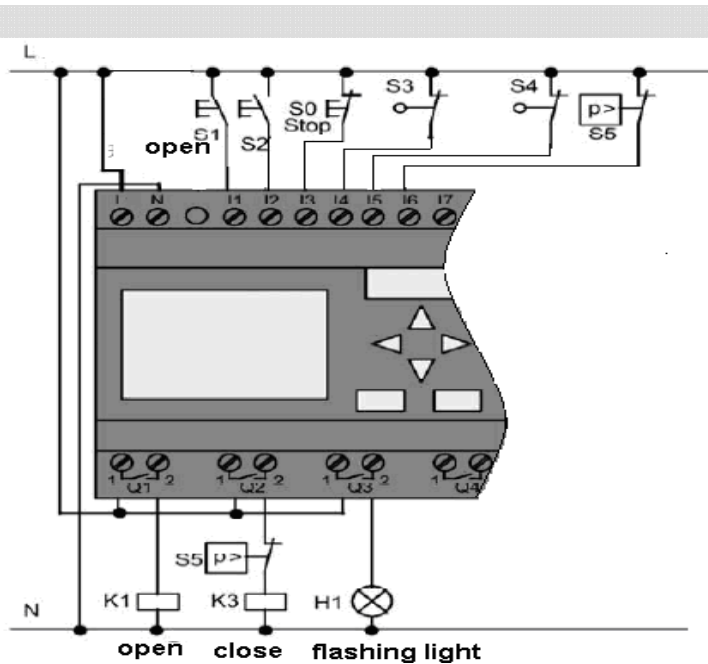

Required components:

- K1 Main contactor
- K2 Main contactor
- S0 (break contact) Off button
- S1 (make contact) Open button
- S2 (make contact) Shutdown button
- S3 (break contact) Open position sensor
- S4 (break contact) Shutdown position sensor
- S5 (break contact) Safety bar

xLogicSoft solution

A xLogic circuit provides a further feature compared to standard controls: The actuation of a safety bar interrupts the closing motion of the gate. Five seconds



before the gate is opens or closes, a flashing light is activated and signals the start of the movement. It continues flashing until the gate has stopped.

In contrast to standard solutions, xLogic offers an easy and economic means of modifying the control system.

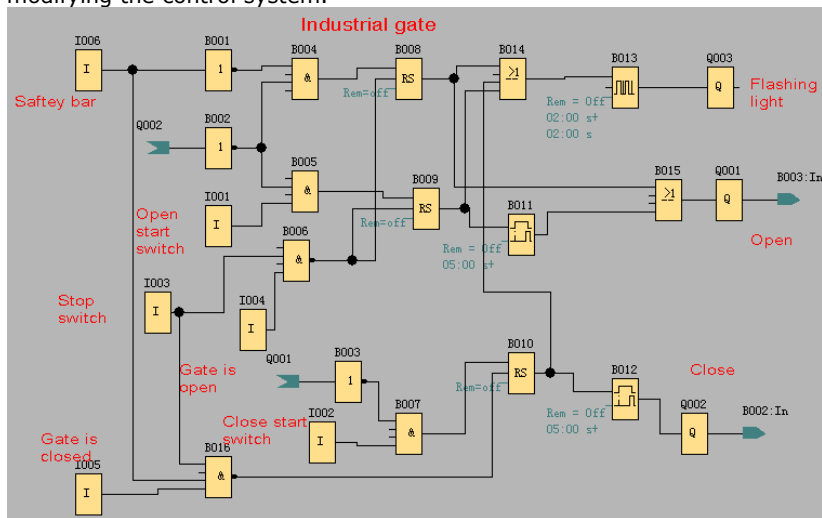

5.5 Daylight lamp system

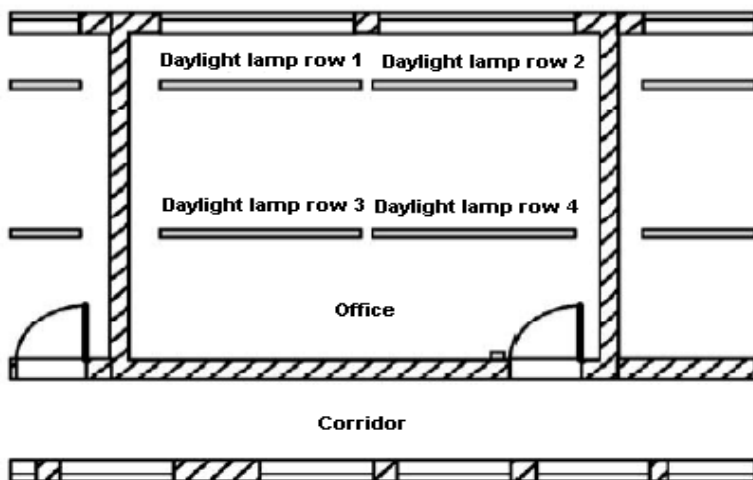

Requirements for lighting system:



- Different daylight lamp rows should be able to be switched on and off handily.
- If window at one side has enough light, the light will be switched off automatically via lightness sensitivity switch.
- The light would be switched off automatically at 8:00 p.m.
- The light can be switched on and off manually at any time.

5.5.1 Standard solution

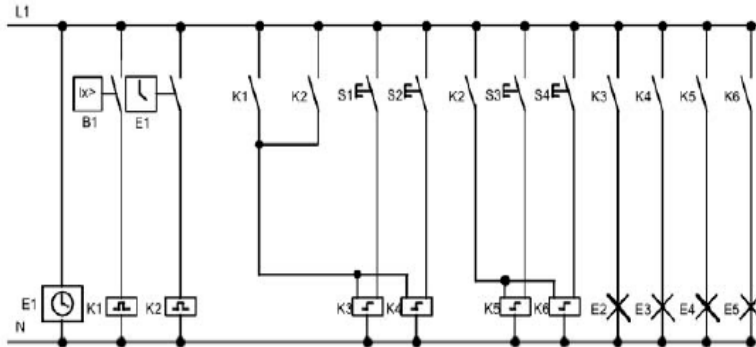

Lighting lamp can be operated by pulse relay controlled by button besides the door. Pulse relay can be repositioned by means of timer and lightness sensitivity switch. Pulse relay may shorten pulse width of "off command".

Required component:

- Button S1—S4
- Daylight control switch B1
- Timer T1
- Pulse relay K1 and K2
- pulse switch K3—K6 able to be switched off collectively

Disadvantages of traditional solution:

- In order to realize function, it need plenty of wiring .
- Vast mechanical parts will result in obvious abrasion and high maintenance costs.
- Modification function can cause much work.

5.5.2 The scheme of ELC-18AC



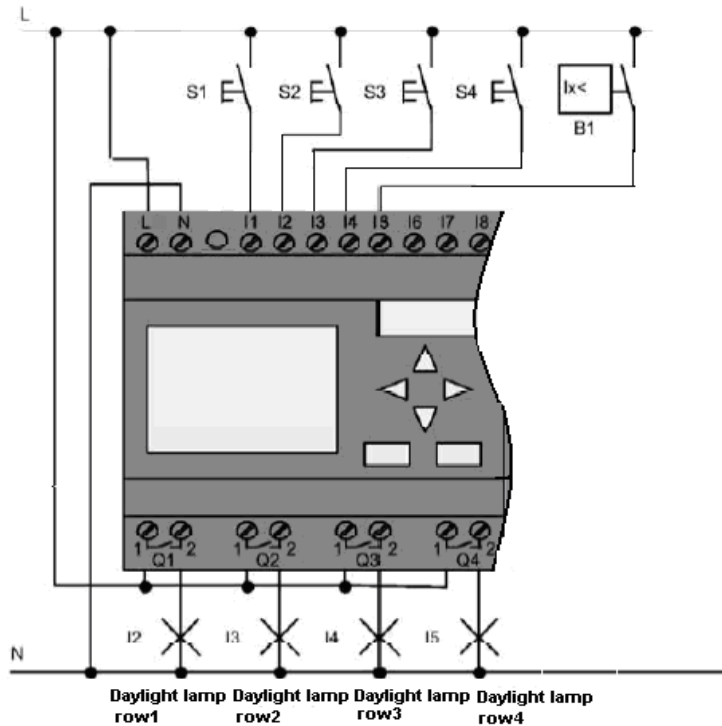

Components:

- S1—S4(make contact) Momentary switch
- B1(make contact) Daylight control switch

Circuit diagram by xLogicsoft:



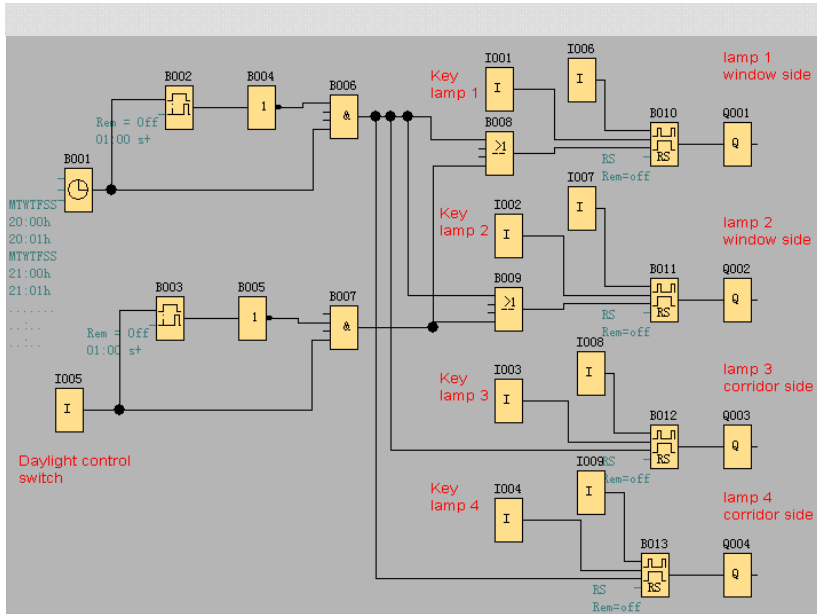

Benefits:

- While power consumption of load does not exceed output of switch's voltage range, lamp can be directly connected to xLogic main module, however, if power consumption of load exceeds output of switch's voltage range, then power contactor would be required.
- You can connect directly lightness sensitivity switch to the input of xLogic.
- Don't need external timer, as this function has been integrated in xLogic.
- It can be installed in a small-sized cabinet, so quite space-saving.
- Less equipment
- Quite easier to modify lighting system
- According to your demand, you may setup supplementary on/off timing (lamp can be switched off in order at the end of day.
- Easier to apply role of lightness sensitivity switch to lamp or already modified lamp row.

5.6 Rainwater pump

Nowadays besides drinkable water in family, rainwater applications is gradually increasing. In this way much costs can be saved, also environment can be improved as well. The application of rain water as follows:



- Wash clothes
- Water system in garden
- Potted plant water
- Wash car
- Scour W.C.

The following figure is to tell you how to run the rainwater application system:

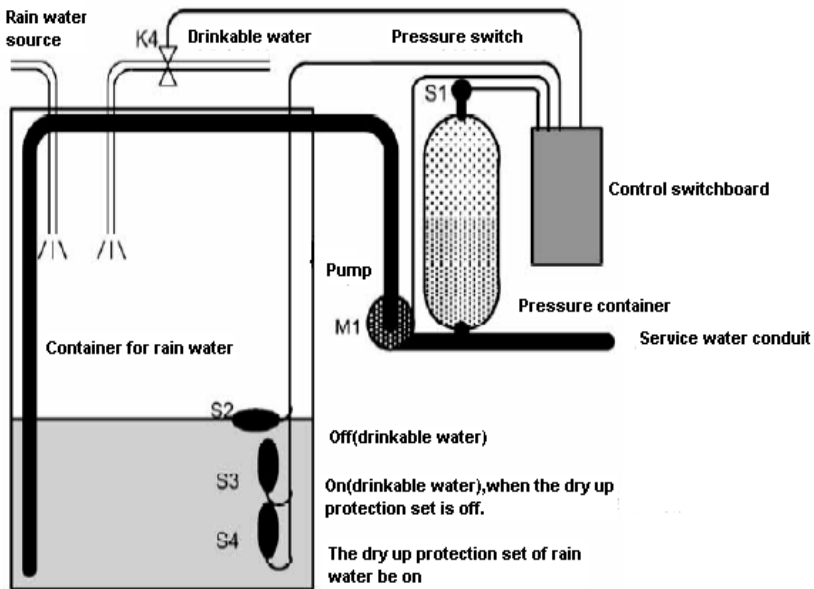

The rain water is collected in the container and then pumped to service water ductwork through pumping station. So you can apply rain water as drinkable water. If the rain water in the container dried up, this system can supply drinkable water.

Requirements for the control system of service water pump

- It can provide service water all day, under the contingency instance, the control system must be able to be switched over to drinkable water system automatically.
- When switching to drinkable water system, it can't interlard rain water.
- If rain container has not enough rain water, service water pump can't be on (rain water dry-up protection).

5.6.1 Standard solution



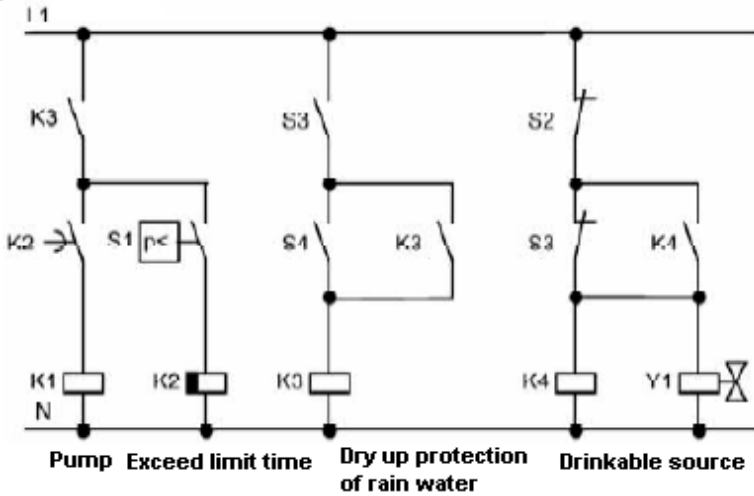

5.6.2 The scheme of ELC-18AC

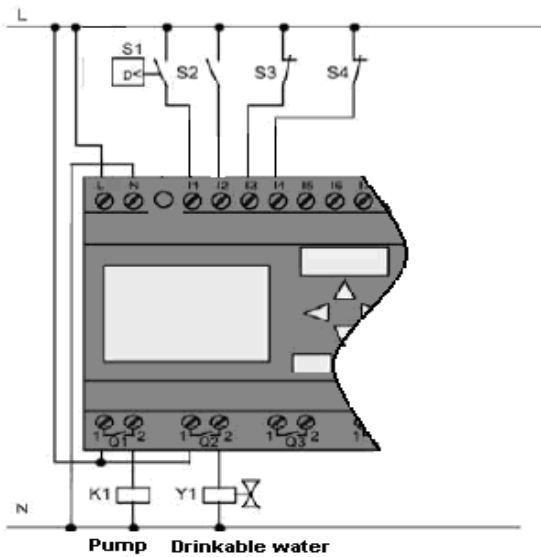

Components:

- K1 main contactor
- Y1 Solenoid valve



- S1 Pressure switch
- S2(make contact) Bobber switch(water level)
- S3—S4(break contact) Bobber switch(water level)

Function block diagram:

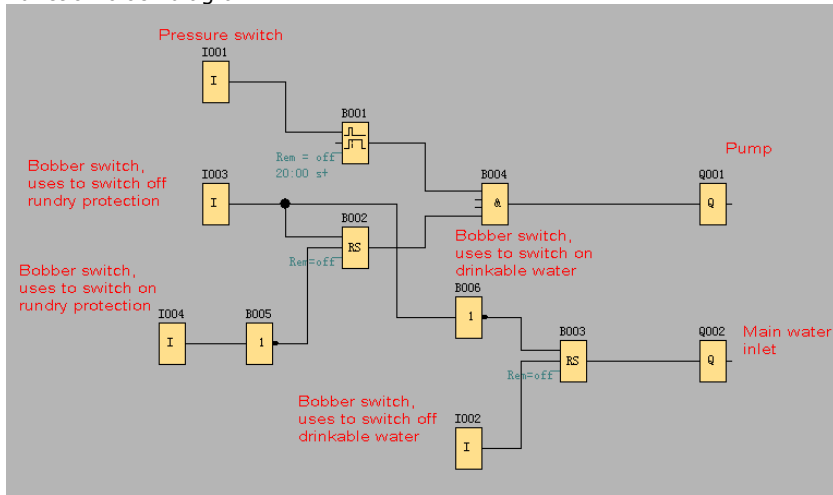

6. xLogic Software

xLogicsoft is available as a programming package for the PC. This software provides many features, for example:

- A graphic interface for offline creation of your circuit program by means of Function Block Diagram (function chart)
- Simulation of your circuit program on the PC
- Generating and printing of an overview chart for the circuit program
- Saving a backup of the circuit program on the hard drive or other media
- Comparing circuit programs
- Easy configuration of blocks
- Transferring the circuit program
 - from the xLogic to the PC and
 - from the PC to xLogic
- Setting the TOD
- Online test: Display of status changes and process variables of xLogic in RUN mode:
 - Status of a digital I/O, shift register bits and cursor keys
 - The values of all analog I/Os
 - The results of all blocks
 - The current values (including the times) of selected blocks
- Starting and stopping circuit program execution via the PC (RUN,



STOP).

The xLogic alternative

As you can see, xLogicSoft represents an alternative to conventional engineering methods:

1. You start by developing the circuit program on your desktop.
2. You simulate the circuit program on your computer and verify its functions, before you actually implement it in your system.
3. You can add comments to the circuit program and create hardcopies.
4. You save a copy of your circuit program to the file system on your PC, to make it directly available for any modifications.
5. It takes only a few key actions to download the circuit program to xLogic.

xLogicSoft

xLogicsoft runs under Windows 95/98,

Windows NT 4.0, Windows Me®, Windows 2000®, Windows XP®, xLogicsoft is capable of client/server operation and offers you a high degree of freedom for creating your circuit program.

xLogicSoft: xLogicV2.0

This is the current version of xLogicsoft. You will find all the functions and the functionality of the devices described in this manual in the version 2.0 and later.

Note

If a full version is not installed, you can carry out an upgrade as follows:

- Install the software from the CD.
- When the system prompts you for the previous version, place the old xLogicsoft CD in CD drive.
- Point your browser to the "...\Install" directory on the CD.

Updates and info



You can download demo versions of the software free of charge from the Internet address specified in the preface.

Installing xLogicsoft(xLogic):

1. Place CD (xLogic) in CD-ROM drive.

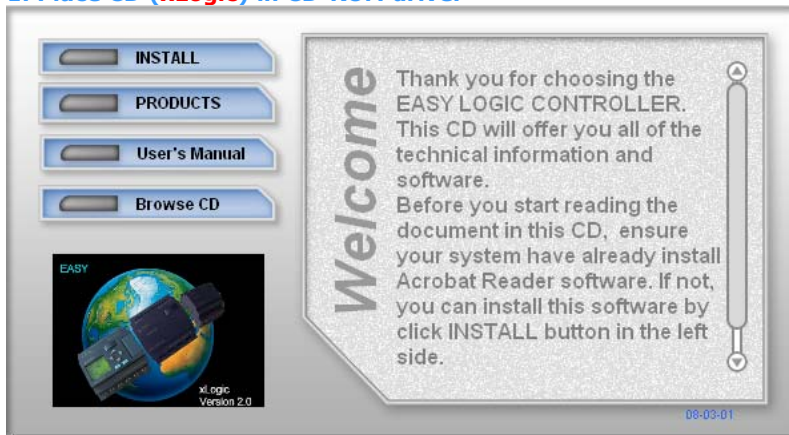

2. Display the CD contents and click the "Browse CD" menu.

3. Double-click on Setup.exe or left-click the "INSTALL" menu directly.



4. Select the language you would like and click OK to confirm

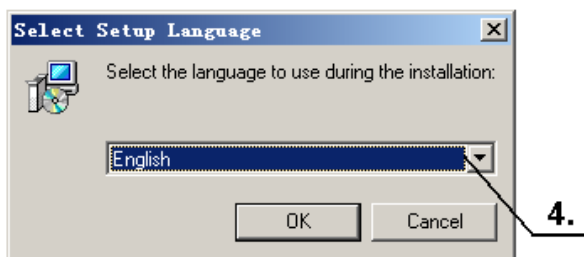

5. If you consent to the license agreement, click Next to confirm.



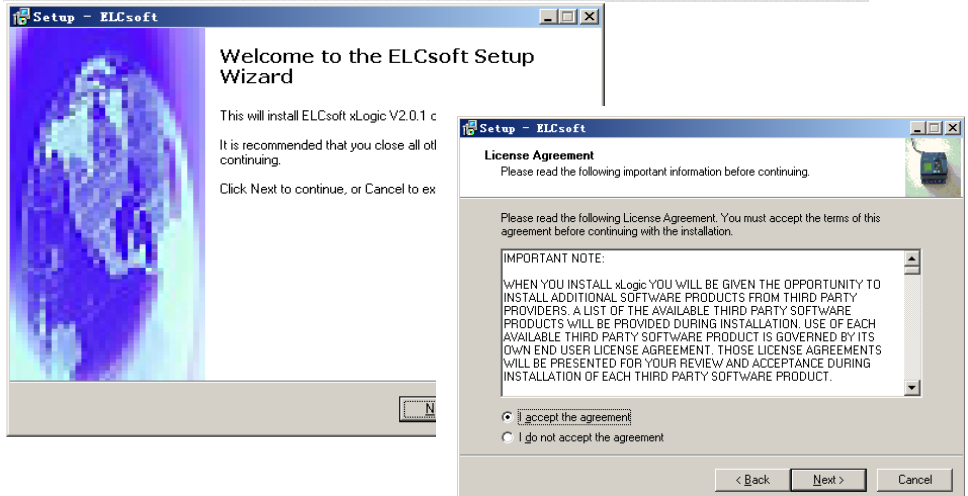

6. Where is the program to be installed? If you do not want to accept the recommended file location:

C:\Program Files\EASY\xLogicsoft xLogic_V2.0, specify another directory using *Browse*.

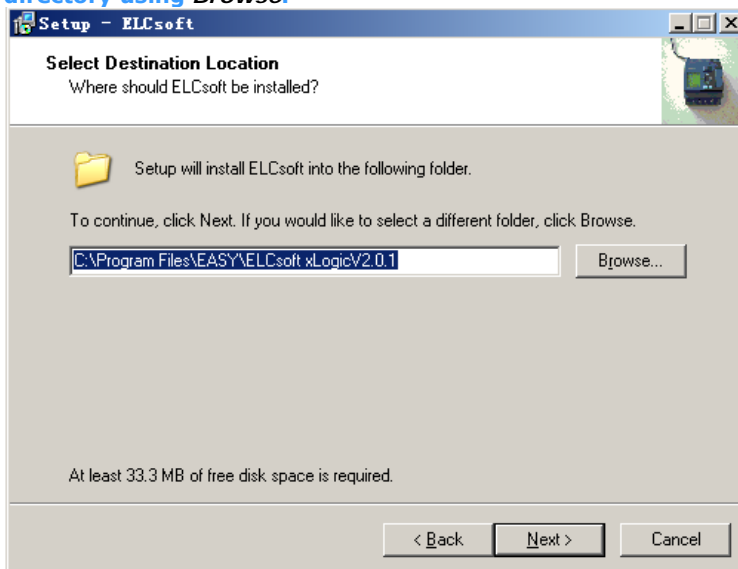

7.If you want to accept the recommended file location, click *Next* to



confirm.

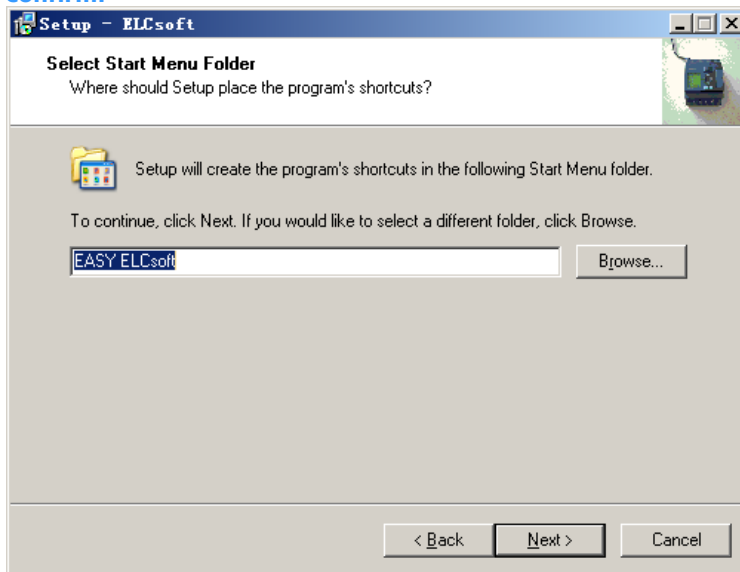

8. In this example, the program icon is to be placed on the desktop. Use *Next* to proceed.

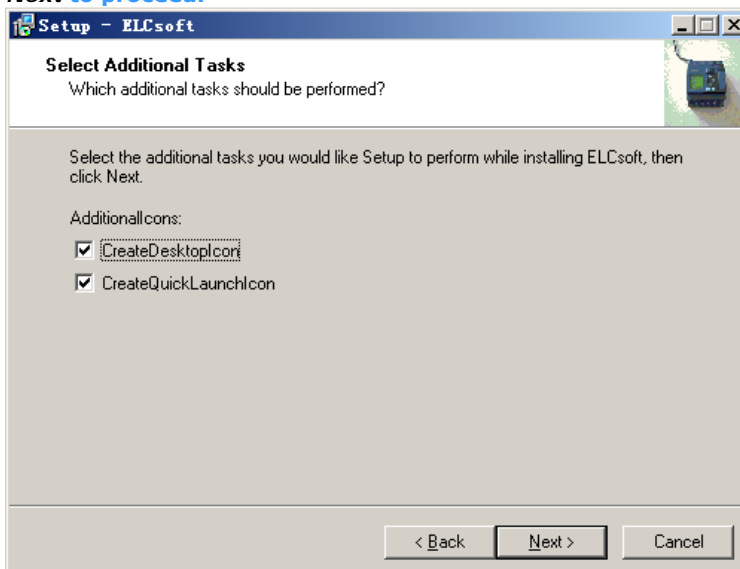

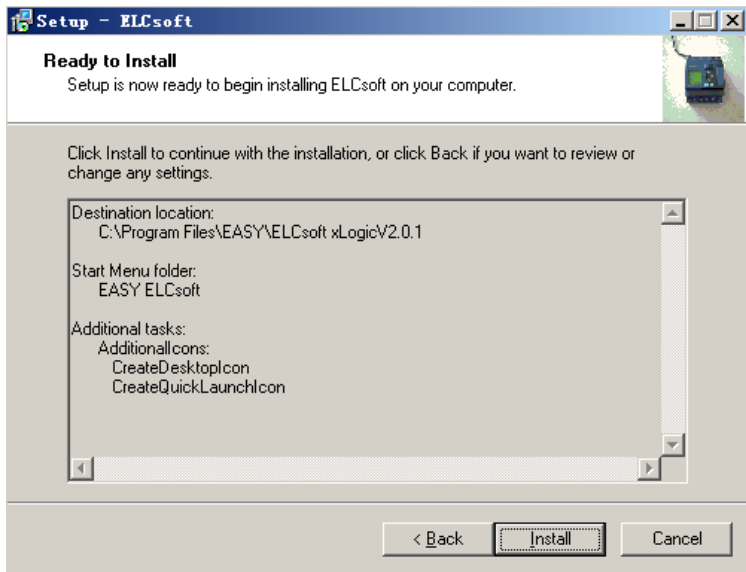

9. Click Install button to install. Program is being installed.

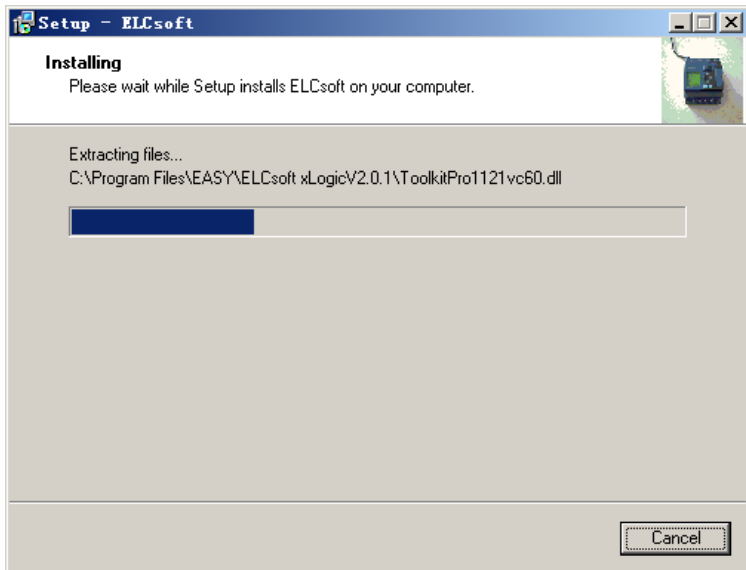

10. The installation is finished. You can start the xLogic program immediately or later by double-clicking the icon on the desktop.

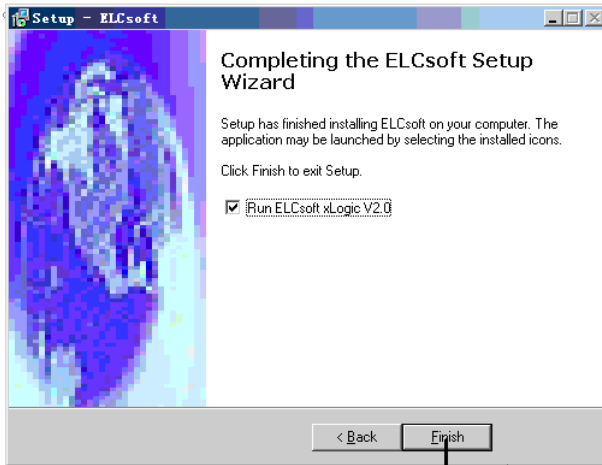

double click



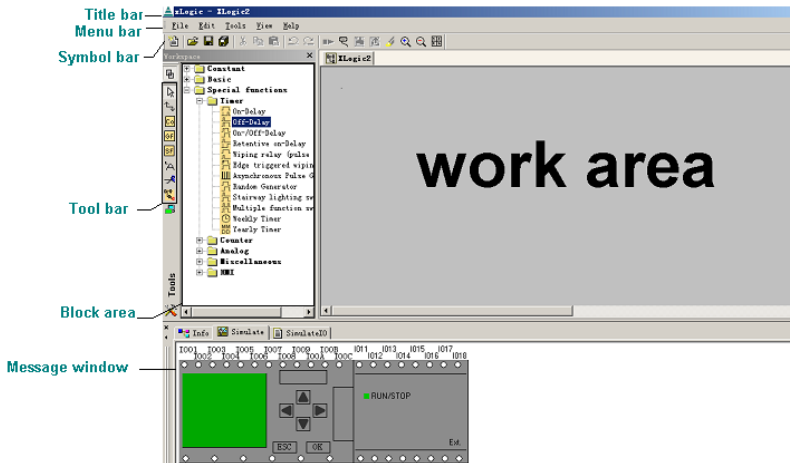

Typical xLogic Applications



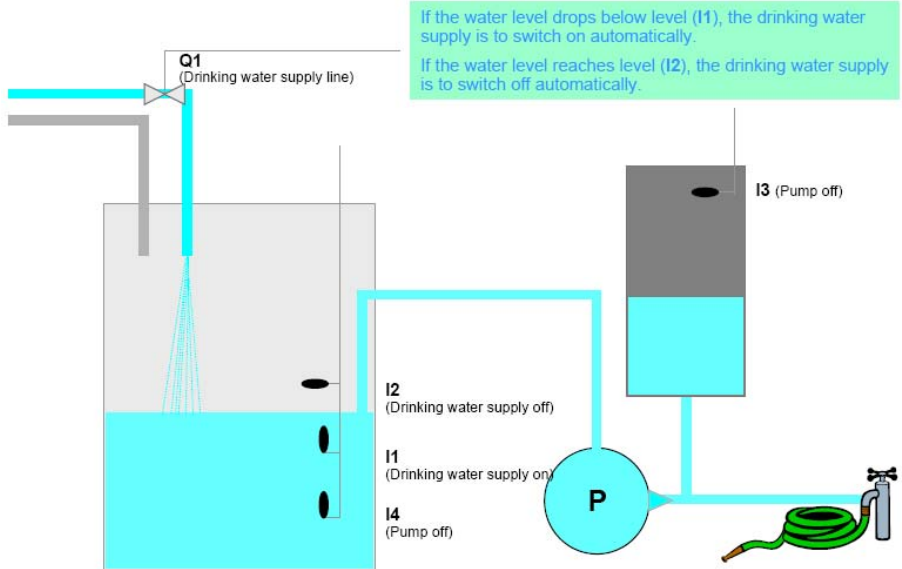



Getting Started with xLogic

Step 1: Inserting Connectors (Co)

How many inputs and outputs are needed to solve this task?

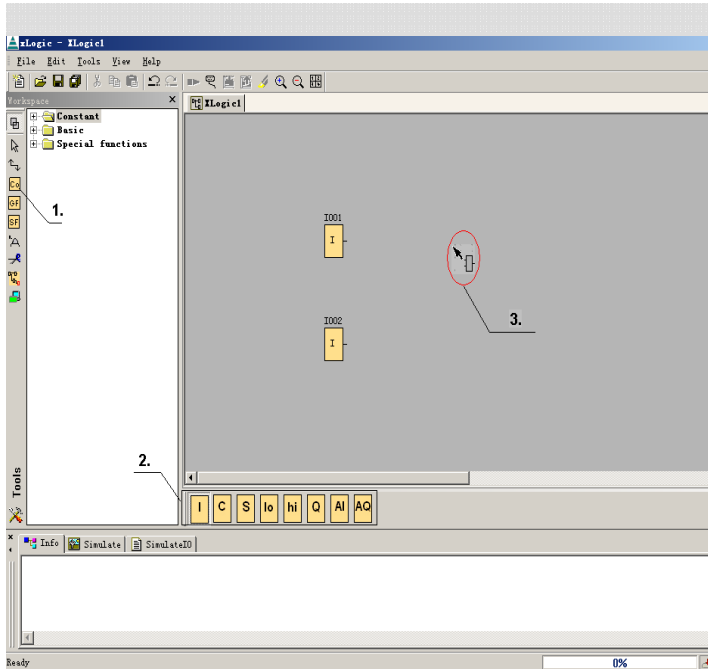

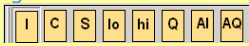

1. The  tool must be selected if you want to place input blocks, output blocks, cursor keys, shift register bits, or constants (high, low) on the programming interface.

2. Then, the specific function blocks are selected using this
Symbol bar: 

3. The following symbol now appears in the work area: 
Now, move the mouse to the required position. The function is inserted by clicking the left mouse button.



Step 2: Inserting Basic Functions (BF)

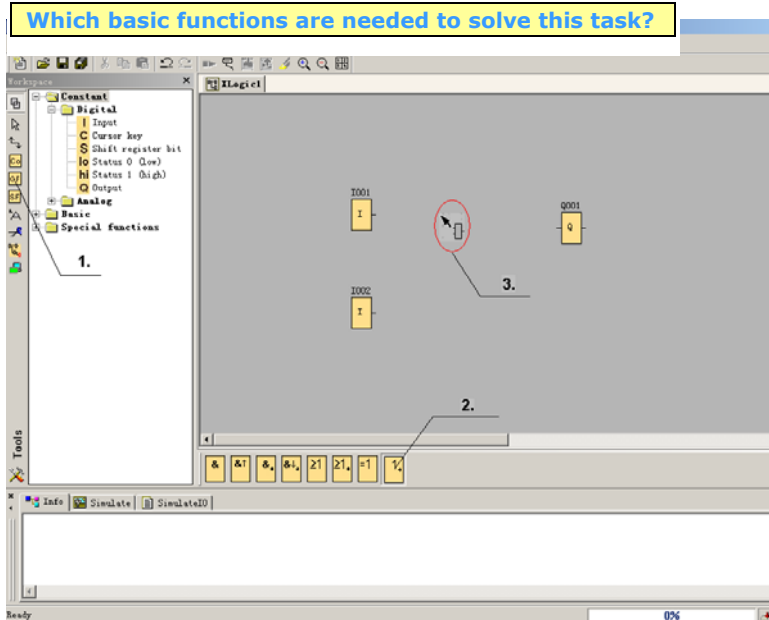

1. Select  the tool if you want to place simple basic logic elements of Boolean algebra on the programming interface.

2. A specific function block is selected using the symbol bar.

3. The following symbol appears in the work area:  Now, move the cursor to the required position. The function is inserted by clicking the left mouse key.



Step 3: Inserting Special Functions (SF)

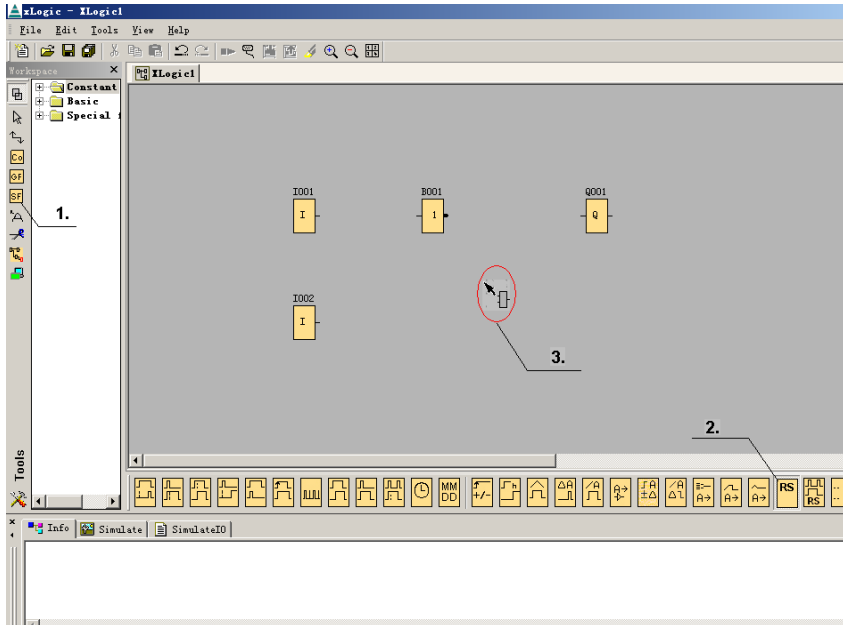

1. Select the  tool if you want to place additional functions on the programming area.

2. A specific function block is selected using the symbol bar.

3. The following symbol now appears in the work area:



Now, move the cursor to the required position. The function is inserted by clicking the left mouse button.

Step 4: Connecting



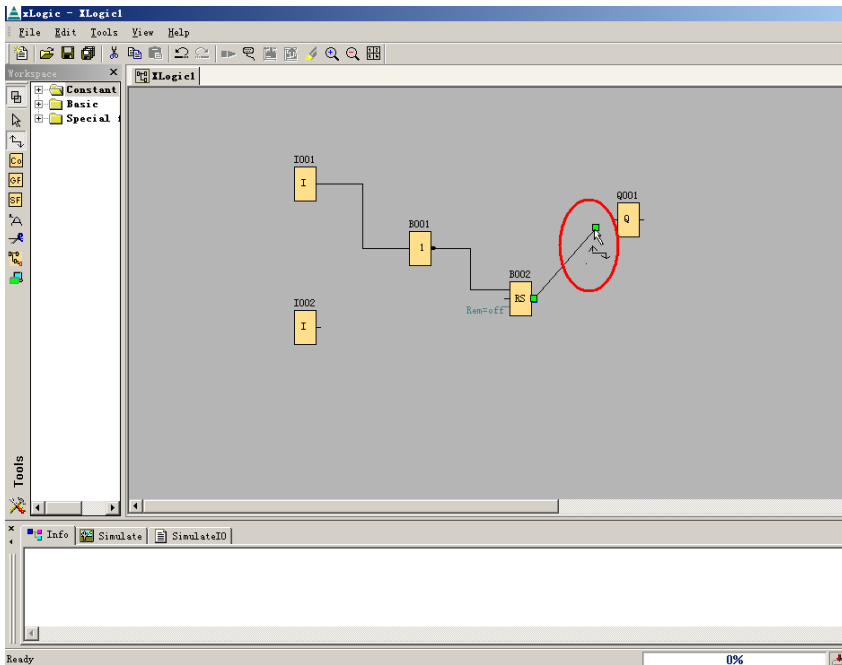

1. The  tool must be selected if you want to connect the inputs and outputs of the function blocks to one another. Now point the mouse to a connection pin of a block and click using the left mouse button. Keeping the mouse button pressed, move the cursor until it is pointing at the pin that you want to connect to and release the mouse button. xLogic then connects the two pins together. This results in a connection between two block pins. Use the same procedure for the other connections.

Step 5: Inserting Text Fields



Inserting text fields makes the program easier to understand.
xLogicsoft gives you several options for inserting text in the
program structure:

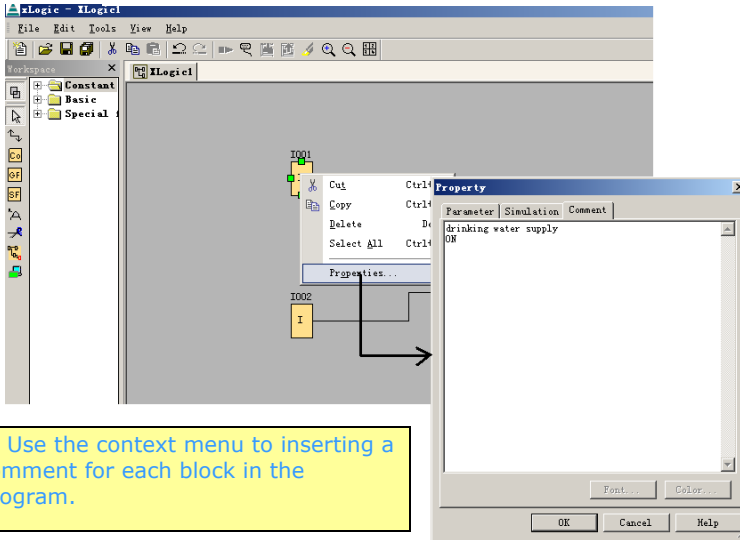

1. Use the context menu to inserting a comment for each block in the program.

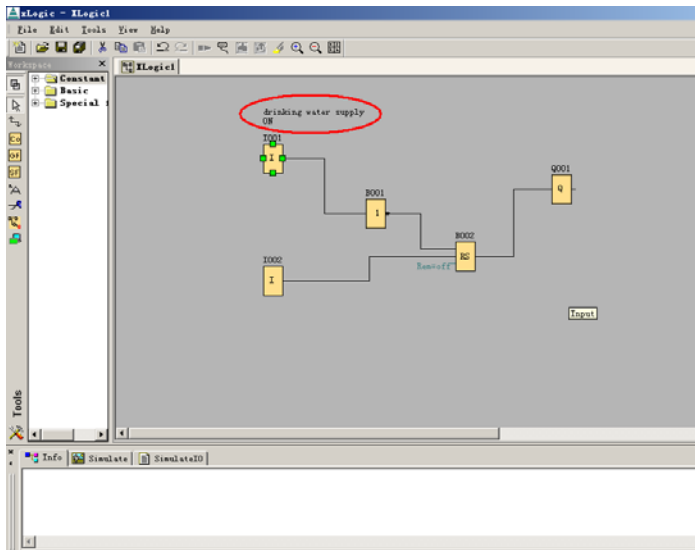

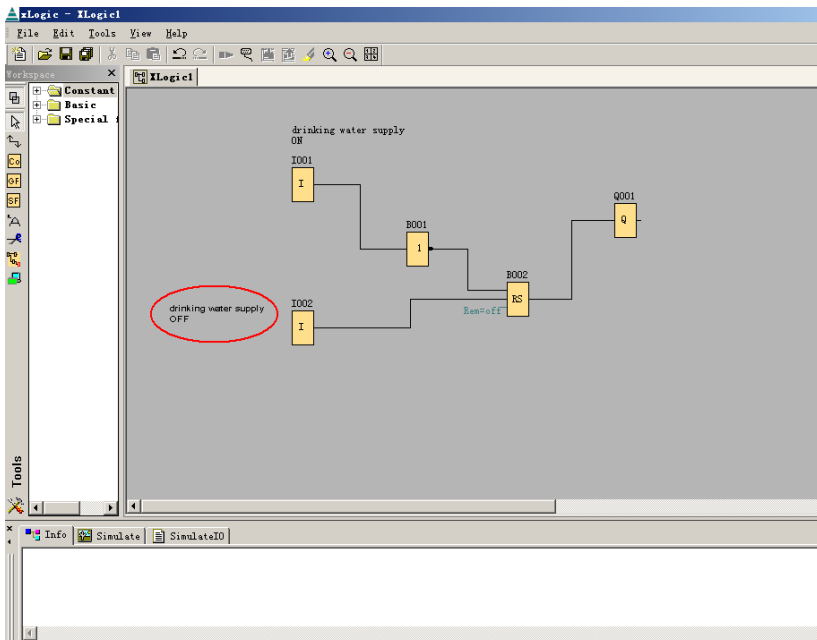
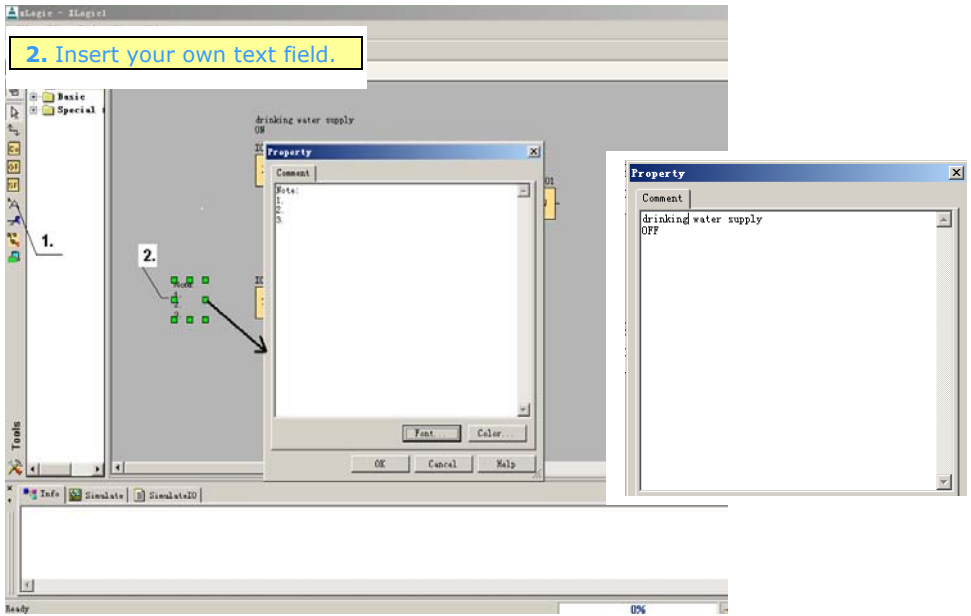

Step 6: Moving



Once the function blocks are inserted and connected, the circuit program is done. Some follow-up work is needed, however, to obtain a view of the created circuit that is visible at a glance and easy to understand. Objects placed in the work area such as function blocks, lines, and text fields can be moved:

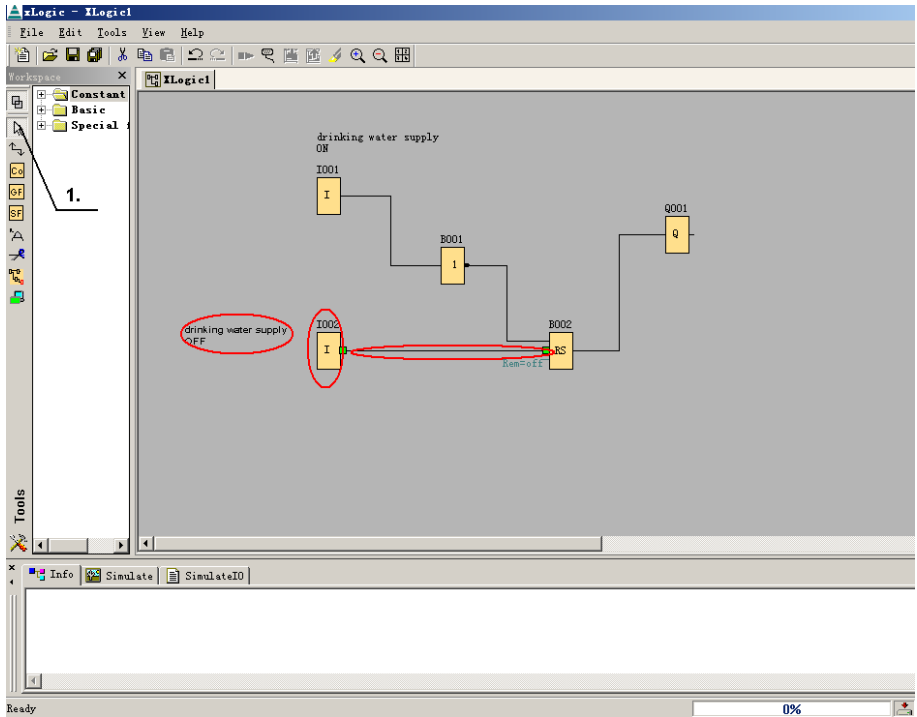

1. Select the tool if you want to move **function blocks**, **text fields**, or **connection lines**.

Step 8: Assigning Parameters to Function Blocks



In the case of special functions and basic functions, there is a tab for comments and one or more tabs for parameters. Here, you can specify values or settings that are to be adopted by the function block in its circuit.

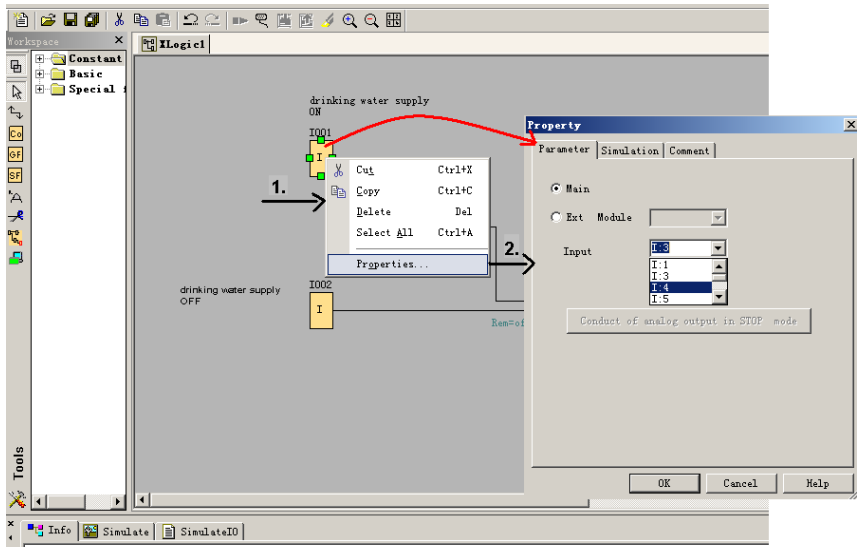

1. Select function and click using the **right** mouse button.

2. Select the *Block Properties* menu item.

or

Double-click the function using the **left** mouse button.

3. Another address can be assigned for each individual input and output block by means of block parameter assignment. However, only the inputs and outputs not already assigned in the circuit program are considered in the selection.

Step 9: Documentation



In the case of large or complex programs, it is often useful to divide up the circuit diagram onto several pages.

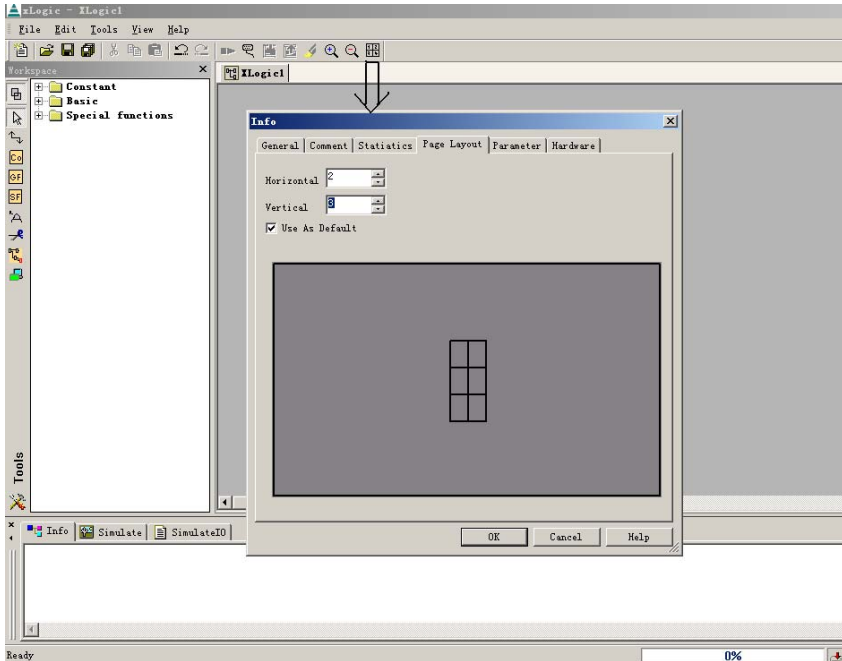

Various connection lines must be separated when the program is divided into several pages.



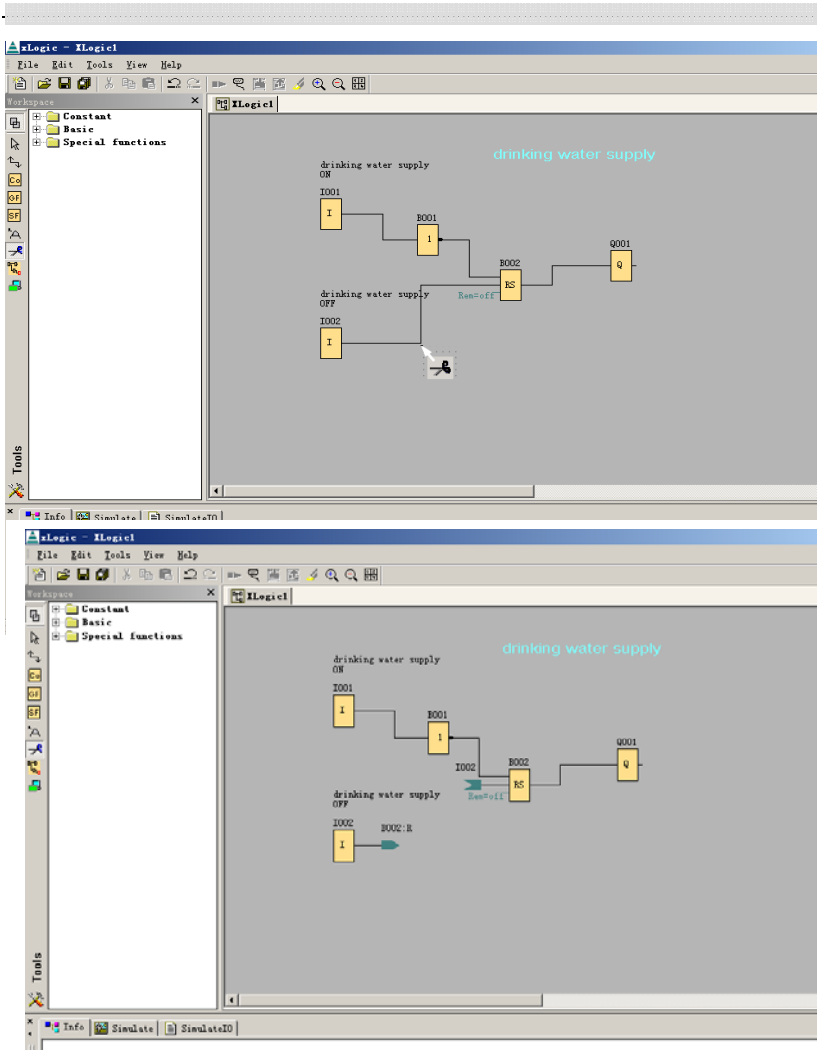

The connection lines can be easily separated using the selected cut tool. The interfaces are uniquely labeled by the page number, block number, and input pin. By clicking on one of the interface wildcards again using the cut tool, the separation is undone.



Step 10: Program Testing

Once the programming and documentation is completed, the program is tested.

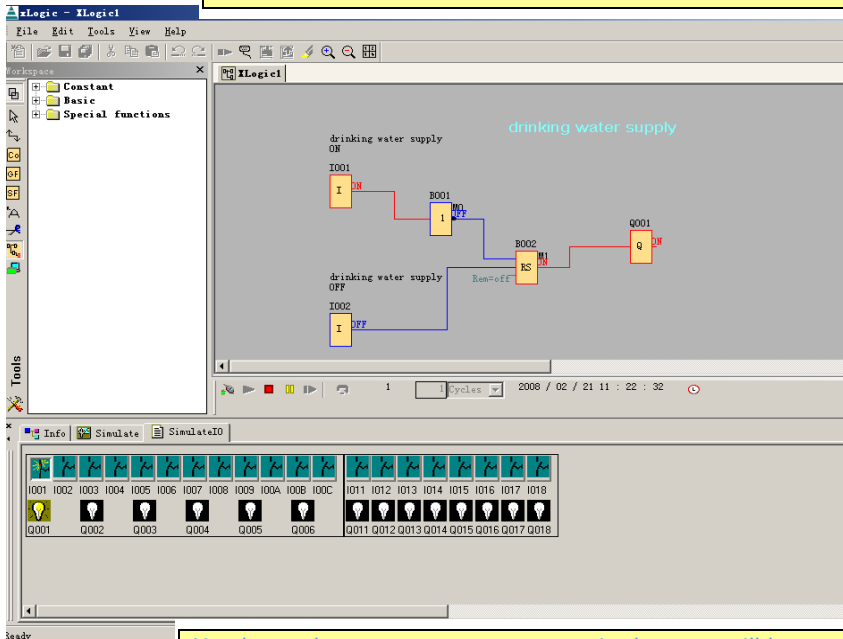

You know that your program can run in, but you still have to check whether it functions as intended. You may also want to modify some parameters .You can experimentally change the input values, test the response to a power failure, and compare your calculations or expectations with the actual output behavior.



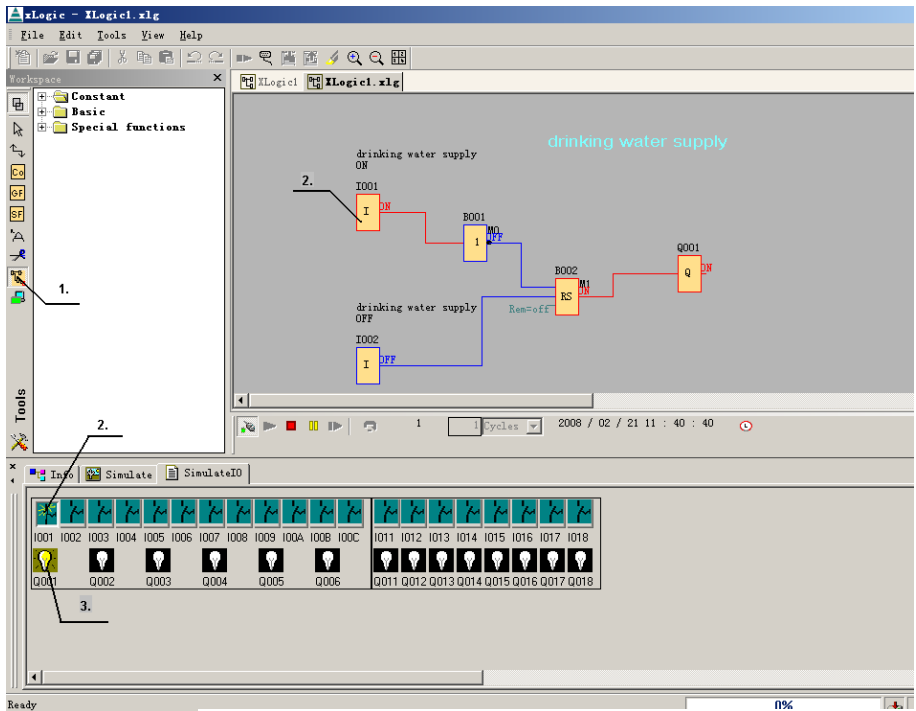

1. Select the  tool if you want to test your program.

2. Once the simulation is activated, a symbol bar for operator control and monitoring of inputs and outputs is called. A software switch is used to simulate a power failure in order to test the retentive features of the circuit behavior.

3. The input states can be modified by clicking the button in the symbol bar (2) or clicking on the inputs in the display.

The connection sequence can be tracked by the change in color of the connection lines from blue (low signal) to red (high signal). This facilitates the detection and removal of errors significantly.



Step 11: Transferring Program to xLogic

When programming in xLogic software, you have the option of first implementing your circuit program and then determining the required unit using the **Tools->Select Hardware** menu command, or you can use the  tool.

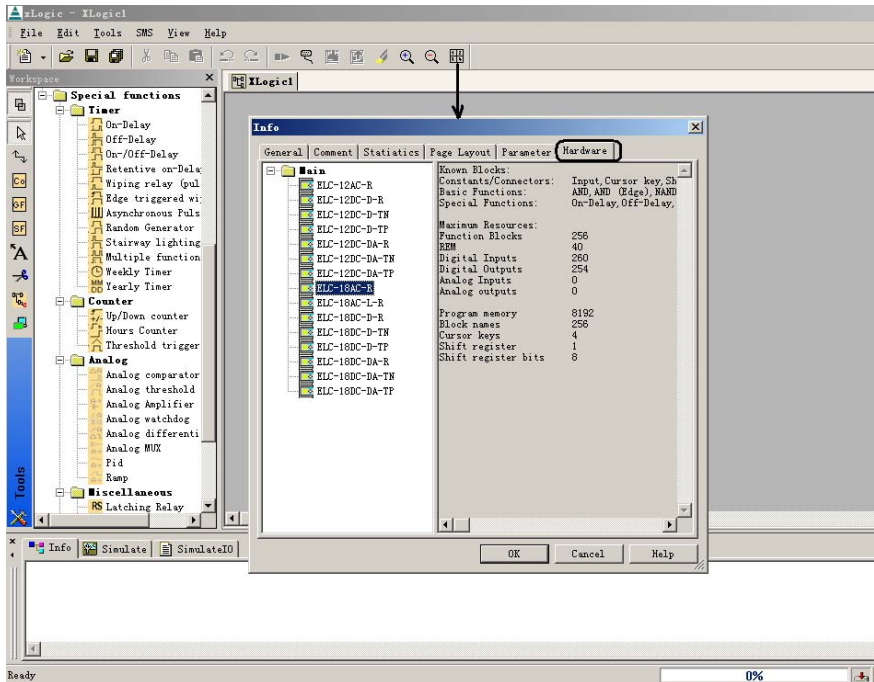

The xLogic unit must be connected with the PC cable for the transfer.

All preparations have been made. The program can now be transferred.



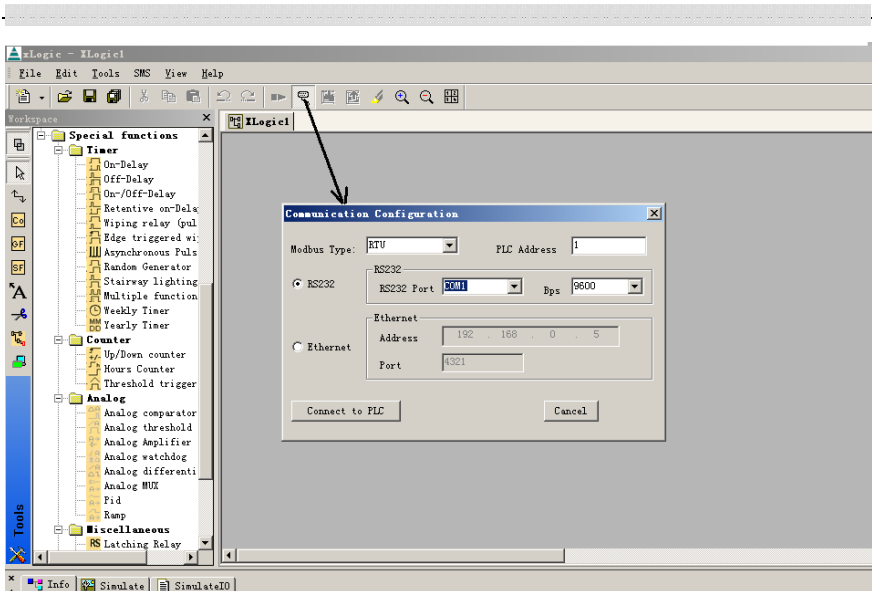

1. Select the  tool to open communication port and confirm with left-clicking "Connect to PLC" by mouse.

COM parameter:

Modbus Type:RTU

PLC Address: 1

Bps:9600

COM Port:which you connect

2. Select the  function to transfer a circuit program created in the PC with **xLogicsoftware** to a xLogic unit.



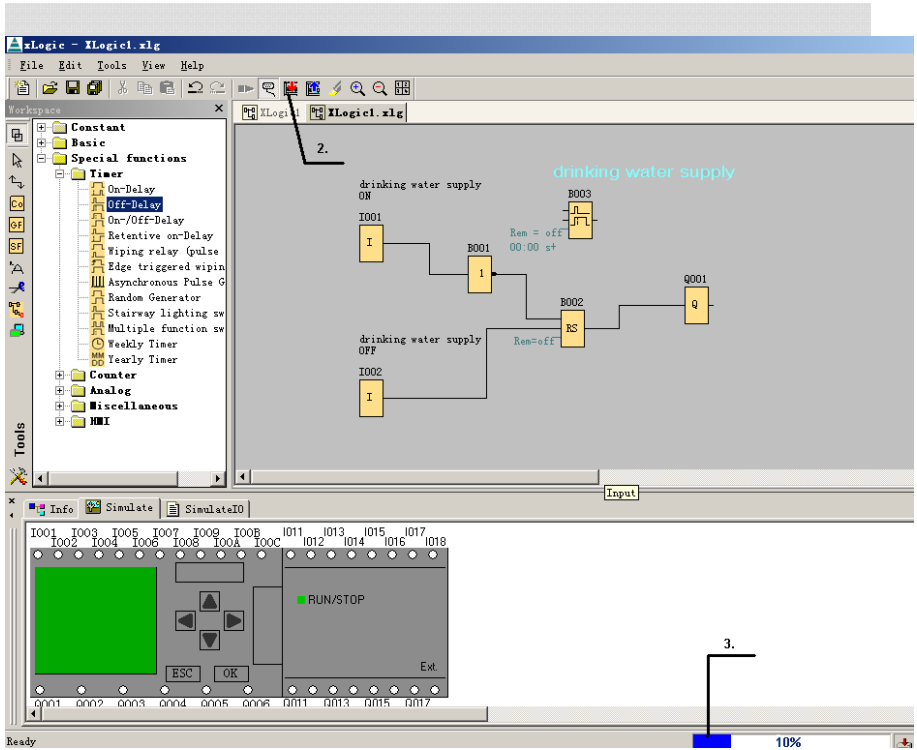

3.A message is displayed in the status bar indicating that whether the data transfer was successful or not.



6.1 Connecting the xLogic to a PC

Connecting the PC cable

To connect the xLogic to a PC, you need the xLogic PC cable(ELC-RS232). Remove the cap from your xLogic and connect the cable to the communication port. Connect the other end of the cable to the serial port of your PC.

Connecting the PC cable to the USB port

If your PC is only equipped with a USB interface (Universal Serial Bus), you will need a ELC-USB module to connect the xLogic cable to this port. For the ELC-USB module information, refer to Chapter 1.

Closing the communication mode

When the data transfer is completed, the connection to the PC is shut down automatically.

Note

If the circuit program created with **xLogic** is password protected, both the circuit program and the password are downloaded to xLogic. The password prompt is enabled at the end of the data transfer. The upload of a password protected program created in xLogic is only possible after the correct password is entered in **xLogic**.



Appendix

A Technical data

A.1 General technical data

Criterion	Tested in accordance with	Values
ELC-18 Series Main Module Dimensions (W x H x D) Weight Installation		95 x 90 x 55 mm Approx. 200 g on a 35 mm profile rail or wall mounting
ELC-12 Series Main Module Dimensions (W x H x D) Weight Installation		72 x 90 x 53 mm Apporox.170g on a 35 mm profile rail or wall mounting
ELC-E-16 Series Expansion Module Dimensions (W x H x D) Weight Installation		72 x 90 x 53 mm Apporox.150g on a 35 mm profile rail or wall mounting
Climatic conditions		
Ambient temperature Horizontal installation Vertical installation Storage/shipping	Low temperature to IEC 6006821 High temperature to IEC 60068-2-2	0 ... 55 °C 0 ... 55 °C -40 °C ... +70 °C
Relative humidity	IEC 60068-2-30	From 10 to 95 % no condensation
Air pressure		795 ... 1080 hPa
Pollutants	IEC 60068-2-42 IEC 60068-2-43	SO ₂ 10 cm ³ /m ³ , 4 days H2S 1 cm ³ /m ³ , 4 days



Criterion	Tested in accordance with	Values
Ambient mechanical conditions		
Protection mode		IP20
Vibrations:	IEC 60068-2-6	5 ... 9 Hz (constant amplitude 3.5 mm) 9 ... 150 Hz (constant acceleration 1 g)
Shock	IEC 60068-2-27	18 shocks (half-sine wave 15g/11 ms)
Drop	IEC 60068-2-31	Drop height 50 mm
Free fall (packaged)	IEC 60068-2-32	1 m
Electro-magnetic compatibility (EMC)		
Emission(Conducted Emission)	EN 55022	Class B
Emission(Radiated Emission)	EN 55022	Class B
Harmonics(Current Harmonics)	EN 61000-3-2	
Flicker(Voltage Fluctuation)	EN 61000-3-3	
ESD(Electrostatic Discharge)	EN 61000-4-2 Severity 3	8 kV air discharge 6 kV contact discharge
RF-Field(Radiated Immunity)	EN 61000-4-3	3V/m
Burst(Electrical Fast Transients)	EN 61 000-4-4	1 kV (supply and signal lines)
Surge(Transients comm.&diff.mode) (applies only to ELC-AC types)	EN 51000-4-5	0.5kV
RF-com.mode(RF continues conducted)	EN 61000-4-6	
V-dips(Voltage dips and Interruption)	EN 61000-4-11	
Cycle time		
Cycle time per function		<0.01ms



A.2 Technical data:

ELC-18 Series and ELC-12 Series

TYPE Parameter	ELC-18DC Series	ELC-12DC Series	ELC-E-16DC
Power			
Power voltage	12-24VDC	12-24VDC	24VDC
Permissible range	1028V DC	1028V DC	10....28VDC
Reverse polarity protection	YES	YES	YES
Power consumption . 24V DC	10...25mA	10...25mA	10...25mA
Power loss at . 24 VDC	0.2....0.6W	0.2....0.6W	0.2....0.6W
Backup of the real-time clock at 25 °C	10 hours	72 hours	NO
Real time accuracy	Max ±5s/day	Max ±5s/day	NO
Digital inputs			
Number	12	8	8
Electrical isolation	NO	NO	NO
Input voltage: Signal 0 signal 1	< 3V DC > 8V DC	< 3V DC > 8V DC	< 3V DC > 8V DC
Input current at Signal 0 Signal 1	< 1.0mA > 1.5mA	< 1.0mA > 1.5mA	< 1.0mA > 1.5mA
Delay time at . 0 to 1 . 1 to 0	Type 1.5ms(I1-IA) < 1.0ms(IB,IC) Type 1.5ms(I1-IA) < 1.0ms(IB,IC)	Type 1.5ms(I1-I7) < 1.0ms(I8) Type 1.5ms(I1-I7) < 1.0ms(I8)	Type 1.5ms
Line length (unshielded)	100m	100m	100m
Digital outputs			
Number	6	4	8
Output type	Relay outputs Transistor outputs	Relay outputs Transistor outputs	Relay outputs Transistor outputs (PNP)



	(PNP)	(PNP)	
--	--------	--------	--

Electrical isolation	Relay outputs: YES Transistor : NO	Relay outputs: YES Transistor : NO	Relay outputs : YES Transistor : NO
Control of a digital input	YES	YES	YES
Output voltage	Transistor 0~24VDC	Transistor 0~24VDC	Transistor 0~24VDC
Continuous current	Transistor : max 0.3A Relay : max 10A per relay	Transistor : max 0.3A Relay : max 10A per relay	Transistor : max 0.3A Relay : max 3A (Q1-Q4), max 10A(Q5-Q8)
Incandescent lamp load (25000 switching cycles) at	Relay: 1000W(240V) 500W(110V)	Relay: 1000W(240V) 500W(110V)	Relay: 1000W(240V) 500W(110V)
Fluorescent tubes with ballast (25000 switching cycles)	Relay: 10 x 58W (at 240VAC)	Relay: 10 x 58W (at 240VAC)	Relay: 10 x 58W (at 240VAC)
Fluorescent tubes, conventionally compensated (25000 switching cycles)	Relay: 1 x 58W (at 240VAC)	Relay: 10 x 58W (at 240VAC)	Relay: 1 x 58W (at 240VAC)
Short circuit-proof and overload-proof	YES	YES	YES
Short-circuit current limitation	Approx. 1 A	Approx. 1 A	Approx. 1 A
Output relay protection	B16 Max 16A	B16 Max 16A	B16 Max 8A(Q1-Q4) Max 16A(Q5-Q8)
Parallel output circuit for power increase	Not permitted	Not permitted	Not permitted
Switching rate			
Mechanical	10Hz	10Hz	10Hz
Ohmic load/lamp load	2Hz	2Hz	2Hz
Inductive load	0.5 Hz	0.5 Hz	0.5 Hz
Analog			
Analog inputs voltage	0~10VDC	0~10VDC	0~10VDC
Analog input Number	ELC-18DC-DA: 8 (DI/AI)	ELC-12DC-DA: 8 (DI/AI)	ELC-E-16DC-DA: 6DI+2(DI/AI)



TYPE Parameter	ELC-18AC Series	ELC-12AC Series	ELC-E-16AC
Power			
Power voltage	110~240VAC	110~240VAC	110~240VAC
Permissible range	85...250VAC	85...250VAC	85...250VAC
Permissible mains frequency	47...63 Hz	47...63 Hz	47...63 Hz
Power consumption	. 10...30mA (110VAC) . 10...20mA (240VAC)	. 10...30mA (110VAC) . 10...20mA (240VAC)	. 10...30mA (110VAC) . 10...20mA (240VAC)
Voltage failure buffering	10ms(110VAC) 20ms(240VAC)	10ms(110VAC) 20ms(240VAC)	10ms(110VAC) 20ms(240VAC)
Power loss	1.1...3.5W(110VAC) 2.4...4.8W(240VAC)	1.1...3.5W(110VAC) 2.4...4.8W(240VAC)	1.1...3.5W(110VAC) 2.4...4.8W(240VAC)
Backup of the real-time clock at 25 °C	10 hours	72 hours	NO
Real time accuracy	Max ±5s/day	Max ±5s/day	NO
Digital inputs			
Input number	12	8	8
Electrical isolation	NO	NO	NO
Input voltage: Signal 0 signal 1	< 40VAC >79VAC	< 40VAC >79VAC	< 40VAC >79VAC
Input current Signal 0 Signal 1	< 0.03mA >0.08mA	< 0.03mA >0.08mA	< 0.03mA >0.08mA
Delay time at . 0 to 1 . 1 to 0	Type 50ms Type 50ms	Type 50ms Type 50ms	Type 50ms Type 50ms
Line length (unshielded)	100m	100m	100m
Digital outputs			
Output number	6	4	8
Output type	Relay outputs	Relay outputs	Relay outputs
Electrical	YES	YES	YES



isolation			
Control of a digital input	YES	YES	YES
Continuous current	MAX. 10A per relay	MAX. 10A per relay	MAX. 3A (Q1-Q4) MAX. 10A(Q5-Q8)
Incandescent lamp load (25000 switching cycles)	1000W(240V) 500W(110V)	1000W(240V) 500W(110V)	1000W(240V) 500W(110V)
Fluorescent tubes with ballast (25000 switching cycles)	10 x 58W (at 240VAC)	10 x 58W (at 240VAC)	10 x 58W (at 240VAC)
Fluorescent tubes, conventionally compensated (25000 switching cycles)	1 X 58W (at 240VAC)	1 X 58W (at 240VAC)	1 X 58W (at 240VAC)
Short circuit-proof cos 1	Power protection B16 600A	Power protection B16 600A	Power protection B16 600A
Short-circuit proof cos 0.5 to 0.7	Power protection B16 900A	Power protection B16 900A	Power protection B16 900A
Protection of output relay	Max 16A characteristic B16	Max 16A characteristic B16	Max 16A characteristic B16
Switching rate			
Mechanical	10 Hz	10 Hz	10 Hz
Ohmic load/lamp load	2 Hz	2 Hz	2 Hz
Inductive load	0.5 Hz	0.5 Hz	0.5 Hz



A.3 Switching capacity and service life of the relay outputs

Ohmic load

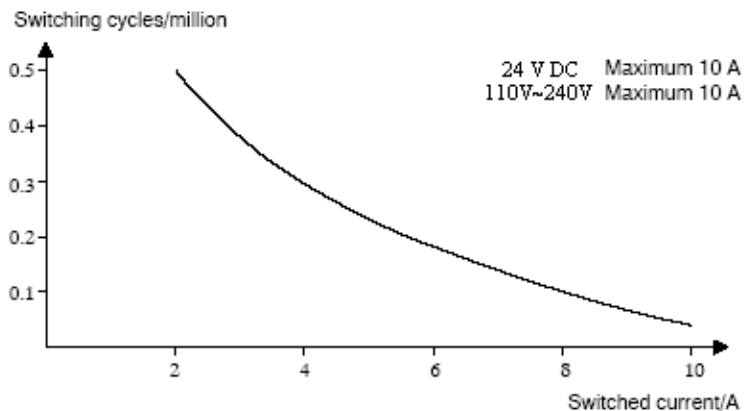

Figure A Switching capacity and service life of the contacts with ohmic load (heating)

Inductive load

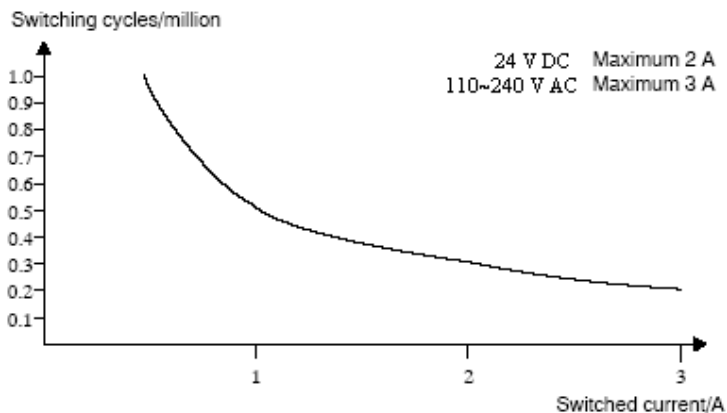

Figure B Switching capacity and service life of the contacts with high inductive load (contactors, solenoid coils, motors).

